



Product manual

ThermCommand FSD EIS Classified Smoke Control Damper

Fire protection

Version 2.0
Issue Date: 23.10.2025



1. Side seal
2. Blade seal
3. Cover of the actuator encasing

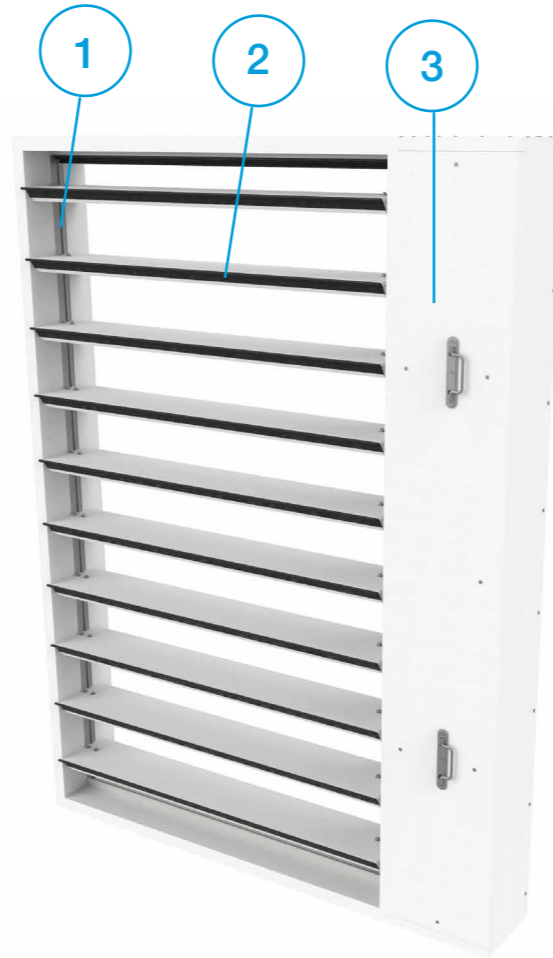

1. Blades
2. Casing
3. Actuator

- ▼ [PRODUCT OVERVIEW](#)
- ▼ [DIMENSIONS](#)
- ▼ [INSTALLATIONS](#)
- ▼ [ACTUATORS](#)
- ▼ [ACCESSORIES](#)
- ▼ [MAINTENANCE AND OPERATION](#)



PRODUCT OVERVIEW

Smoke control dampers FSD are used in smoke extraction systems for extraction of smoke gases or providing supply air to one or more fire compartments. Smoke control dampers consist of calcium silicate casing and calcium silicate damper blade.

Calcium silicate blade is equipped with galvanized steel shaft and with seals. Seals are made out of silicon and of intumescent material. Smoke control dampers FSD are produced in sizes from 200x240 till 1200x2040 mm and are equipped with Belimo actuator in version 24V or 230V.

Activation of smoke control dampers equipped with electric actuator can be via smoke detector or remotely via control signal. Rearming of the electric smoke damper can also be done remotely via control signal. All electric actuators are equipped with end switches for position signalling.

In case of smoke detection the actuator is triggered by a signal. The signal can come either from a duct smoke detector or from a fire alarm system. FSD smoke control damper have two safe positions: open and closed. Depending on the fire site and the path of the smoke to be extracted, the safe position is either "open" or "closed". The blades of FSD move to the safe position when receiving an automatically or manually triggered control signal. Damer is safe to install in wall or duct, when installing the damper on the wall it is possible to install it with blades horizontally and vertically.

FSD smoke control damper complies with the requirements of EN 12101-8, and is tested to EN 1366-10 and EN 1366-2. Classification of damper is EI 120/90 (vedw-hod i↔o) S1000 Cmod HOT 400/30 MA multi.



- ▼ [PRODUCT OVERVIEW](#)
- ▼ [DIMENSIONS](#)
- ▼ [INSTALLATIONS](#)
- ▼ [ACTUATORS](#)
- ▼ [ACCESSORIES](#)
- ▼ [MAINTENANCE AND OPERATION](#)



CLASSIFICATION

FSD smoke control damper is tested according to EN 1366-10 "Fire resistance tests for service installations - Smoke control dampers" and EN 1366-2 "Fire resistance tests for service installations – Fire dampers".

Classification of the FSD smoke control dampers is defined according to EN 13501-4 "Fire classification of construction products and building elements using data from fire resistance tests"

Classification of FSD smoke control damper is:

EI 120/90 (vedw-hod i↔o) S1000 Cmod HOT 400/30 MA multi

Smoke damper should be installed according installation manual which can be found within this document.

Please consult latest Declaration of Performance on our website:



For more information about certificates, visit our website:

- E** - Integrity
- I** - Insulation
- 120/90** - Classification time in minutes
- ve** - Damper installed in vertical position
- ho** - Damper installed in horizontal position
- i↔o** - Fire performance criteria are met on both sides
- S** - Smoke leakage
- Cmod** - modulating drive
- MA** - manual intervention, can be used also as an AA classified control damper
- MULTI**- usage in compartments classified as "multi", can be used also in compartments classified as "single"

TECHNICAL DATA

Product label

- 1 - Manufacturer
- 2 - Serial number
- 3 - Production date
- 4 - Type
- 5 - Dimension
- 6 - Mechanism type
- 7 - Nominal voltage
- 8 - Signalisation (end contacts)
- 9 - IP protection
- 10 - Free space
- 11 - Number of the European standard and year of its publication
- 12 - Declaration of performance
- 13 - Classification according to EN13501-4
- 14 - Barcode
- 15 - CE mark





USER MANUALS

1		
2	SERIAL NUMBER:	204517000200001
3	PRODUCTION DATE	19.01.2024
4	TYPE:	FSD – 850x840 – M230 – S
5	DIMENSION:	850x840
6	ACT. MECHANISM:	M230
7	NOMINAL VOLTAGE:	AC 230V
8	SIGNALISATION	Yes
		LOCATION:
		IP PROTECTION: IP54
		FREE SPACE (dm²): 52,96
		Leakage rated
15	 1396 – CPR – 0227	
	EN12101 – 8:2011 Smoke control damper Multi compartment For fire classification of product consult declaration of performance. DOP 1715 – 1/02 – 2023	
	EI 120/90 (vedw, hod i < – > o)S1000 C mod HOT 400/30 MA multi	
	THIS DAMPER SHALL BE INSTALLED AS PER THE MANUFACTURER'S INSTRUCTIONS	
	 204517000200001	

- ▼ [PRODUCT OVERVIEW](#)
- ▼ [DIMENSIONS](#)
- ▼ [INSTALLATIONS](#)
- ▼ [ACTUATORS](#)
- ▼ [ACCESSORIES](#)
- ▼ [MAINTENANCE AND OPERATION](#)



PRODUCT OVERVIEW

FSD SMOKE CONTROL DAMPER

Product specifications

Nominal sizes FSD	200x240 - 1200x2040 [mm]
Casing length	250 mm
Temperature range	-30 °C ... 50 °C
Volume flow rate range	up to 82080 m ³ /h
Pressure level 2	-1000 up to 500 Pa
Casing air leakage	Class C, EN 1751
EC conformity	EU Construction Products Regulation no. 305/2011 EN 12101-8 – Smoke and heat control systems EN 1366-10 – Fire resistance tests for service installations EN 1366-2 – Fire resistance tests for service installations EN 13501-4 – Fire classification of construction products and building elements – Fire resistance tests on components of smoke control EN 1751 – Ventilation for buildings – Air terminal devices

Pressure drop tables

Pressure drop values are described with the “Zeta” values for each size. The exact pressure drop in [Pa] is calculated using the following formula: $\Delta p [Pa] = \zeta * v^2 * 0,6$

* ζ is Zeta value from the tables below, v is airflow velocity in [m/s]

Zeta values

HxB	200	250	300	350	400	450	500	550	600	650	700	750	800	850	900	950	1000	1050	1100	1150	1200
240	0,658	0,637	0,624	0,614	0,608	0,602	0,598	0,595	0,592	0,59	0,588	0,586	0,585	0,583	0,582	0,581	0,58	0,579	0,579	0,578	0,577
440	0,586	0,568	0,556	0,548	0,542	0,537	0,533	0,53	0,528	0,526	0,524	0,522	0,521	0,52	0,519	0,518	0,517	0,516	0,516	0,515	0,515
640	0,554	0,536	0,525	0,517	0,512	0,507	0,504	0,501	0,499	0,497	0,495	0,493	0,492	0,491	0,49	0,489	0,488	0,488	0,487	0,487	0,486
840	0,535	0,518	0,508	0,5	0,494	0,49	0,487	0,484	0,482	0,48	0,478	0,477	0,476	0,475	0,474	0,473	0,472	0,471	0,471	0,47	0,47
1040	0,523	0,507	0,496	0,489	0,483	0,479	0,476	0,473	0,471	0,469	0,468	0,466	0,465	0,464	0,463	0,462	0,462	0,461	0,46	0,46	0,459
1240	0,515	0,499	0,488	0,481	0,476	0,472	0,468	0,466	0,464	0,462	0,46	0,459	0,458	0,457	0,456	0,455	0,454	0,453	0,453	0,452	0,452
1440	0,509	0,493	0,482	0,475	0,47	0,466	0,463	0,46	0,458	0,456	0,455	0,453	0,452	0,451	0,45	0,449	0,449	0,448	0,447	0,447	0,446
1640	0,504	0,488	0,478	0,471	0,465	0,461	0,458	0,456	0,454	0,452	0,45	0,449	0,448	0,447	0,446	0,445	0,444	0,444	0,443	0,443	0,442
1840	0,5	0,484	0,474	0,467	0,462	0,458	0,455	0,452	0,45	0,448	0,447	0,446	0,445	0,444	0,443	0,442	0,441	0,44	0,44	0,439	0,439
2040	0,496	0,48	0,47	0,463	0,459	0,455	0,452	0,448	0,446	0,444	0,444	0,443	0,442	0,441	0,44	0,439	0,438	0,436	0,437	0,435	0,436



- ▼ [PRODUCT OVERVIEW](#)
- ▼ [DIMENSIONS](#)
- ▼ [INSTALLATIONS](#)
- ▼ [ACTUATORS](#)
- ▼ [ACCESSORIES](#)
- ▼ [MAINTENANCE AND OPERATION](#)

MODELS

- Smoke control damper is used in smoke extract systems and is certified for installation in a wall or duct.
- Produced according to standard EN 12101-8 and tested according to EN 1366-10 and EN 1366-2 norms for smoke control systems
- Smoke control dampers come in dimensions from 200x240 mm till 1200x2040 mm. Volume flows up to 82080 m³/h with airflow velocities up to 12 m/s.
- Damper casing is produced out of rigid, thermally stable calcium silicate material



PRODUCT OVERVIEW

FSD SMOKE CONTROL DAMPER

Actuators

Belimo BEN, BEE and BE actuators are used specifically for smoke control dampers. Type of the model used depends on the size of the smoke control damper.

M230-S

Belimo 230 V operation is controlled via 2-wire open/close control. The actuator is overload-proof and can thus remain energized even at the end stops. The Safety Position Lock™ reliably holds the smoke control damper in the defined safety position in case of fire, thus ensuring maximum safety. The hand crank included in the shipment can be used for manual operation of the actuator. Two micro-switches with fixed settings are installed in the actuator for indicating the damper end positions. It should be noted with this application however that the contacts can no longer be used in the milliampere range after larger currents have been applied to them, even if this has taken place only once. The position of the damper blade can be read off on a mechanical position indication

M24-S

Belimo 24V operation is controlled via 2-wire open/close control. The actuator is overload-proof and can thus remain energized even at the end stops. The Safety Position Lock™ reliably holds the smoke control damper in the defined safety position in case of fire, thus ensuring maximum safety. The hand crank included in the shipment can be used for manual operation of the actuator. Two micro-switches with fixed settings are installed in the actuator for indicating the damper end positions. It should be noted with this application however that the contacts can no longer be used in the milliampere range after larger currents have been applied to them, even if this has taken place only once. The position of the damper blade can be read off on a mechanical position indication

M24-S-ST

Belimo 24V operation is controlled via 2-wire open/close control. The actuator is overload-proof and can thus remain energized even at the end stops. The Safety Position Lock™ reliably holds the smoke control damper in the defined safety position in case of fire, thus ensuring maximum safety. The hand crank included in the shipment can be used for manual operation of the actuator. Two micro-switches with fixed settings are installed in the actuator for indicating the damper

end positions. It should be noted with this application however that the contacts can no longer be used in the milliampere range after larger currents have been applied to them, even if this has taken place only once. The position of the damper blade can be read off on a mechanical position indication

The actuator is fitted with connection plugs. This means that it can be integrated via communication and the power supply unit in the control and monitoring system SBSE-Control.

M24-S-SR

Belimo “-SR” 24V actuators operation is controlled via 2..10V analog signal. The Safety Position Lock™ reliably holds the smoke control damper in the defined safety position in case of fire, thus ensuring maximum safety. The hand crank included in the shipment can be used for manual operation of the actuator. Two microswitches with fixed settings are installed in the actuator for indicating the damper end positions. It should be noted with this application however that the contacts can no longer be used in the milliampere range after larger currents have been applied to them, even if this has taken place only once. The position of the damper blade can be read off on a mechanical position indicator.

Ordering key

(1) Damper type (2) Dimension (3) Actuator type

FSD - **BxH** - **M24-S**

(1) **FSD**

(2) Dimensions
200x240 - 1200x2040

(3) Actuator type:
M230-S - electric actuator AC 230 V
M24-S - electric actuator AC/DC 24 V
M24-S-ST - electric actuator AC/DC 24 V
with connection plug
M24-S-SR - modulating electric actuator AC/DC 24V

FSD Dimensions

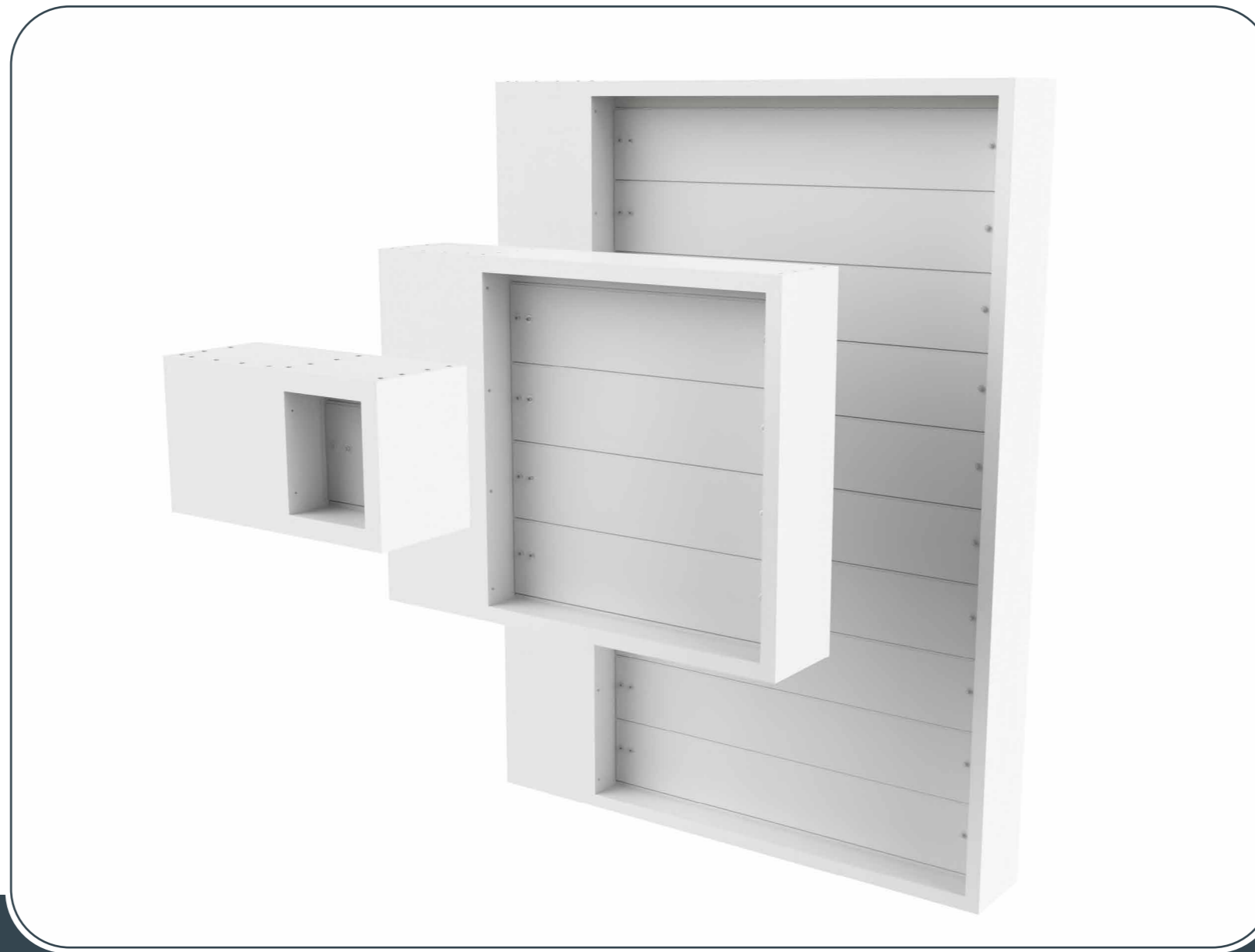

- ▼ [PRODUCT OVERVIEW](#)
- ▼ [DIMENSIONS](#)
- ▼ [INSTALLATIONS](#)
- ▼ [ACTUATORS](#)
- ▼ [ACCESSORIES](#)
- ▼ [MAINTENANCE AND OPERATION](#)

DIMENSIONS

FSD SMOKE CONTROL DAMPER

Weight [kg]

HxB	200	250	300	350	400	450	500	550	600	650	700	750	800	850	900	950	1000	1050	1100	1150	1200
240	24,6	25,8	27	28,2	29,4	31,7	32,9	34	35,2	36,4	37,6	39,9	41,1	42,3	43,4	44,6	45,8	47	49,3	50,5	51,7
440	34	36,4	37,6	38,7	41,1	42,3	44,6	45,8	48,1	49,3	51,7	52,8	55,2	56,4	57,5	59,9	61,1	63,4	64,6	66,9	68,1
640	43,4	45,8	48,1	50,5	51,7	54	56,4	58,7	59,9	62,3	64,6	66,975	68,1	70,5	72,8	75,2	76,3	78,7	81	83,4	84,6
840	54	56,4	58,7	62,2	63,4	65,8	68,1	71,6	72,8	75,2	77,5	81,075	82,2	84,6	88,1	90,4	91,65	94	97,5	99,8	102,2
1040	63,4	65,8	69,3	71,6	74	77,5	79,9	82,2	85,7	88,1	90,4	94	96,3	98,7	102,2	104,5	106,9	110,4	112,8	115,1	118,6
1240	72,8	76,3	78,7	82,2	85,7	88,1	91,6	95,1	97,5	101	104,5	106,9	110,4	113,9	116,3	119,8	122,2	125,7	129,2	131,6	135,1
1440	83,4	85,7	89,3	92,8	96,3	99,8	103,4	106,9	110,4	113,9	117,5	121	124,5	128	131,6	135,1	137,4	141	144,5	148	151,5
1640	92,8	96,3	99,8	103,4	108,1	111,6	115,1	118,6	123,3	126,9	130,4	133,9	138,6	142,1	145,7	149,2	152,7	157,4	160,9	164,5	168
1840	102,2	106,9	110,4	115,1	118,6	123,3	126,9	131,6	135,1	139,8	143,3	148	151,5	156,2	159,8	164,5	168,0	172,7	176,2	180,9	185
2040	111,6	116,3	121	125,7	130,4	133,9	138,6	143,3	148	152,7	157,4	160,9	165,6	170,3	175	179,7	183,3	188	192,7	197,4	202,1

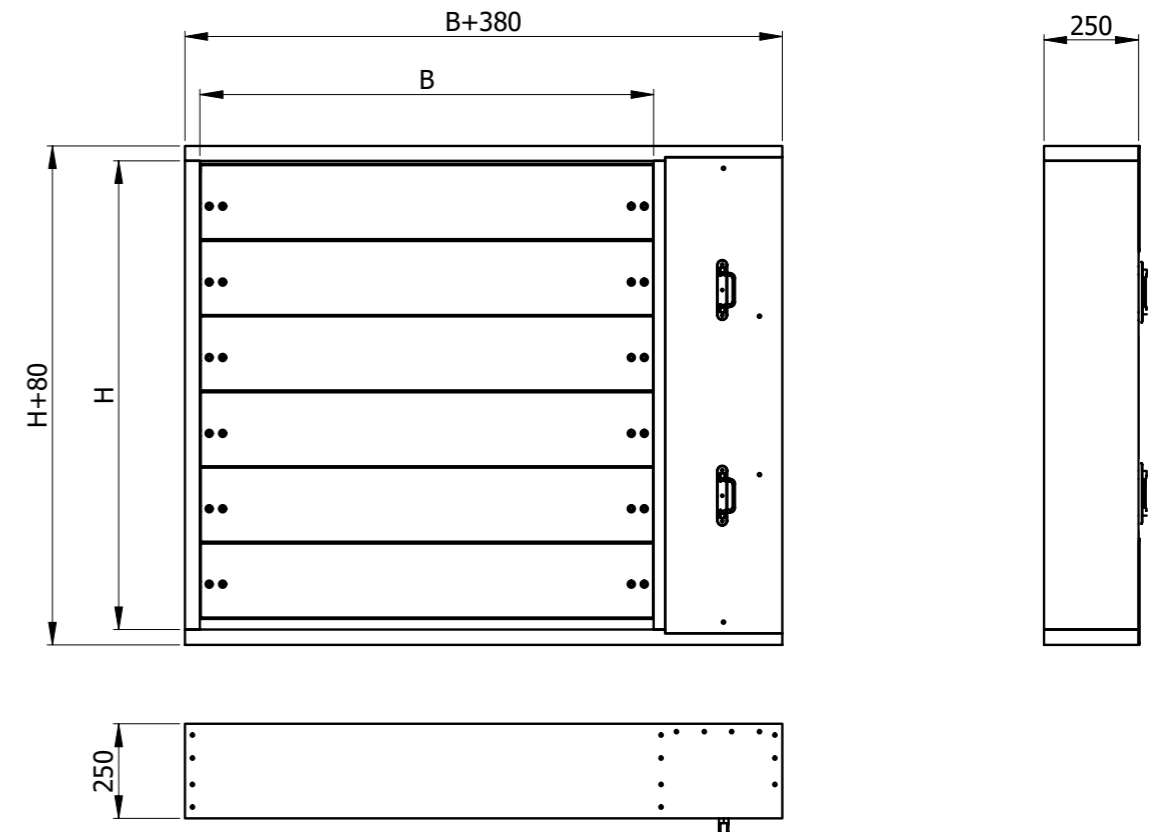

Dimensional range

Actuator types per dimension

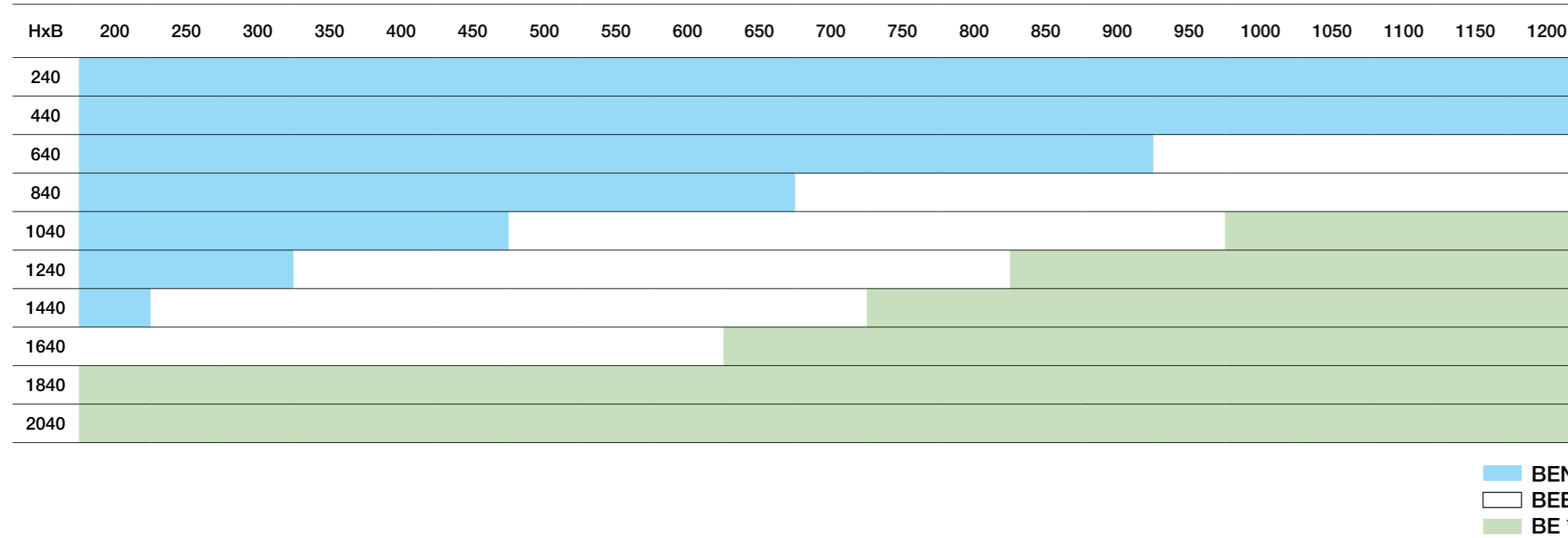

*Not available for modulating drives (M24-S-K)

- ▼ [PRODUCT OVERVIEW](#)
- ▼ [DIMENSIONS](#)
- ▼ [INSTALLATIONS](#)
- ▼ [ACTUATORS](#)
- ▼ [ACCESSORIES](#)
- ▼ [MAINTENANCE AND OPERATION](#)



















Effective area Aef [m2]





HxB	200	250	300	350	400	450	500	550	600	650	700	750	800	850	900	950	1000	1050	1100	1150	1200
240	0,03	0,04	0,04	0,05	0,06	0,06	0,07	0,08	0,09	0,09	0,10	0,11	0,11	0,12	0,13	0,14	0,14	0,15	0,16	0,16	0,17
440	0,06	0,08	0,09	0,11	0,12	0,14	0,15	0,17	0,18	0,20	0,21	0,23	0,24	0,26	0,27	0,29	0,30	0,32	0,33	0,35	0,36
640	0,09	0,12	0,14	0,16	0,19	0,21	0,23	0,25	0,28	0,30	0,32	0,35	0,37	0,39	0,42	0,44	0,46	0,49	0,51	0,53	0,56
840	0,12	0,16	0,19	0,22	0,25	0,28	0,31	0,34	0,37	0,40	0,44	0,47	0,50	0,53	0,56	0,59	0,62	0,65	0,69	0,72	0,75
1040	0,16	0,20	0,23	0,27	0,31	0,35	0,39	0,43	0,47	0,51	0,55	0,59	0,63	0,67	0,70	0,74	0,78	0,82	0,86	0,90	0,94
1240	0,19	0,24	0,28	0,33	0,38	0,42	0,47	0,52	0,57	0,61	0,66	0,71	0,75	0,80	0,85	0,90	0,94	0,99	1,04	1,08	1,13
1440	0,22	0,28	0,33	0,39	0,44	0,50	0,55	0,61	0,66	0,72	0,77	0,83	0,88	0,94	0,99	1,05	1,10	1,16	1,21	1,27	1,32
1640	0,25	0,32	0,38	0,44	0,51	0,57	0,63	0,69	0,76	0,82	0,88	0,95	1,01	1,07	1,14	1,20	1,26	1,33	1,39	1,45	1,52
1840	0,28	0,36	0,43	0,50	0,57	0,64	0,71	0,78	0,85	0,92	1,00	1,07	1,14	1,21	1,28	1,35	1,42	1,49	1,57	1,64	1,71
2040	0,32	0,40	0,47	0,55	0,63	0,71	0,79	0,87	0,95	1,03	1,11	1,19	1,27	1,35	1,42	1,50	1,58	1,66	1,74	1,82	1,90

FSD SMOKE CONTROL DAMPER

INSTALLATION

Check for more information about certificate installations in the declaration of performance





Range	Supporting construction	Wall thickness	Supporting construction details	Type of installation	Classification	Pressure difference	Details	Construction type	Sealing type	
200 x 240 - 1200 x 2040	Rigid wall	≥100mm	Aerated concrete wall, $\rho \geq 500\text{kg/m}^3$	Dry installation, mineral wool 140 kg/m ³ , intumescent fire resistant sealant	EI 90 (vev, i↔o) S1000 Cmod HOT 400/30 MA multi	-1000 to 500 Pa				
		≥100mm	Concrete wall, $\rho \geq 500\text{kg/m}^3$			-1000 to 500 Pa				
		≥100mm	Brick wall, $\rho \geq 500\text{kg/m}^3$			-1000 to 500 Pa				
200 x 240 - 1200 x 2040	Flexible wall with type F gypsum plasterboards	≥100mm	Flexible wall with type F gypsum plasterboards (EN520), mineral wool up to 115 kg/m ³	Installation in duct-own design, boards and glue	EI 90 (vev, i↔o) S1000 Cmod HOT 400/30 MA multi	-1000 to 500 Pa				
	Vertical duct		Duct tested on EN1366-8 or EN1366-9			EI 120 (ved, hod, i↔o) S1000 Cmod HOT 400/30 MA multi	-1000 to 500 Pa			
	Horizontal duct		Duct tested on EN1366-8 or EN1366-9			EI 120 (ved, hod, i↔o) S1000 Cmod HOT 400/30 MA multi	-1000 to 500 Pa			

-  Aerated concrete ($\geq 550 \text{ kg/m}^3$), more than 100 mm thick
-  Concrete wall ($\geq 500 \text{ kg/m}^3$) wall, more than 100 mm thick
-  Brick wall ($\geq 500 \text{ kg/m}^3$) wall, more than 100 mm thick
-  Flexible wall with type F gypsum plasterboards (EN520), mineral wool up to 115kg/m²,

Construction of the duct

Smoke control dampers for multi compartments may be used with ducts that have been tested to EN 1366-9 (Single compartment smoke extraction ducts) and to EN 1366-8 (Smoke extraction ducts) and that are constructed either from materials of the same density ($\rho \approx 500 \text{ kg/m}^3$) as the tested material or from the same material with a greater density or thickness. During the test, a channel made of calcium silicate plates from the company Promat, Promatect L500, was used.

FSD SMOKE CONTROL DAMPER

-  Horizontal duct installation
-  Vertical duct installation
-  Sealing with mineral wool and ablating coating
-  Connect the boards with Promat Kleber K84 and screws

- ▼ [PRODUCT OVERVIEW](#)
- ▼ [DIMENSIONS](#)
- ▼ [INSTALLATIONS](#)
- ▼ [ACTUATORS](#)
- ▼ [ACCESSORIES](#)
- ▼ [MAINTENANCE AND OPERATION](#)



INSTALLATION

The FSD Smoke control damper is always tested in standardized support frames (both in a rigid wall and in a flexible wall with type F gypsum plasterboards) in accordance with EN 1366-2: 2015. The results obtained are valid for all similar support frames which have a thickness and/ or density and/or fire resistance similar or greater than the one on the test. Depending on where the dampers are installed, country-specific regulations may apply to ventilation applications.

The smoke control damper will never be, in practice, in the open position at the beginning of the smoke hazard when manually operated (MA). FSD smoke control dampers may be installed in wall systems if these walls have been erected in compliance with regulations and the manufacturer's instructions, and if the information on the respective installation situation applies and the following requirements are met.

When installed on a wall the dampers are suitable only for installation in a vertical position, with the blade axis horizontal or vertical.

Dampers and duct must be suspended separately.

The ductwork must be suspended in such way that the transfer of all loads from the adjoining ventilation duct to the damper body is completely excluded. Adjacent duct must be suspended or supported as required by the duct suppliers. Smoke extraction ducts can be connected to a smoke control damper as per national authority regulations. Make sure that the smoke control damper is not exposed to any external mechanical forces or that the duct connection is affecting the functional operation of the damper. Connections should be performed according to the instructions in this manual.

The gap in the installation opening between the smoke control damper and the wall can be increased by up to 50% of the gap area or decreased to the smallest amount that still provides sufficient space for the seal.

Warning:

- Avoid damaging the casing
- Avoid casing deformation during installation and commissioning
- Make sure that the product is installed in a way that is accessible for future inspection and maintenance
- Avoid deformation of the casing during mounting and sealing
- During installation, avoid applying force to the damper blades.

FSD SMOKE CONTROL DAMPER

Recommendation:

- Unload on a flat and dry surface
- Avoid shocks to the damper
- When using forklift for installation, make sure to support the upper side of the smoke damper with wooden support beams

Installation

Center

- wall min. 100mm

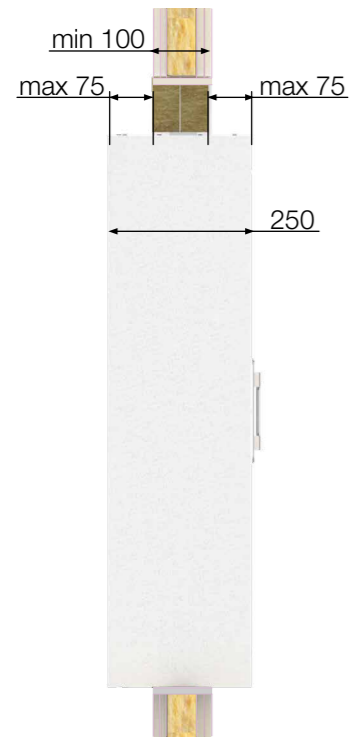

Flush left

- installation side
- wall min. 175mm

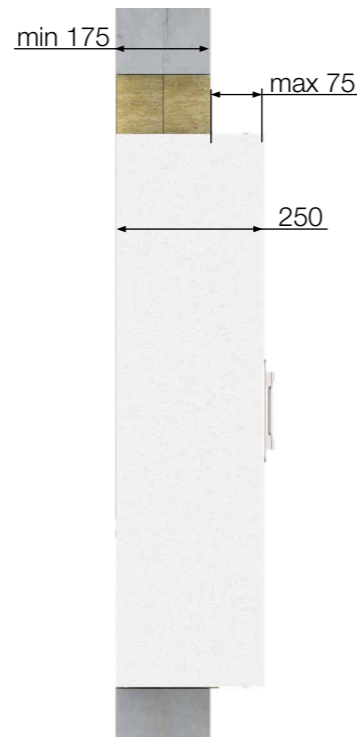

Flush right

- operation side
- wall min. 175mm

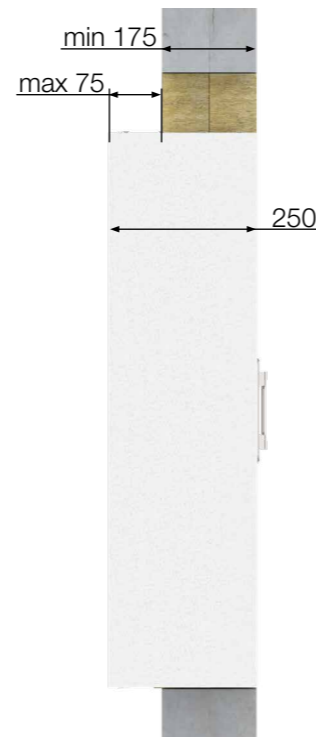

Place a protective foil between the door and intumescent fire resistant sealant to prevent the doors from sticking.



- ▼ [PRODUCT OVERVIEW](#)
- ▼ [DIMENSIONS](#)
- ▼ [INSTALLATIONS](#)
- ▼ [ACTUATORS](#)
- ▼ [ACCESSORIES](#)
- ▼ [MAINTENANCE AND OPERATION](#)

Installation gap and screw-on sides

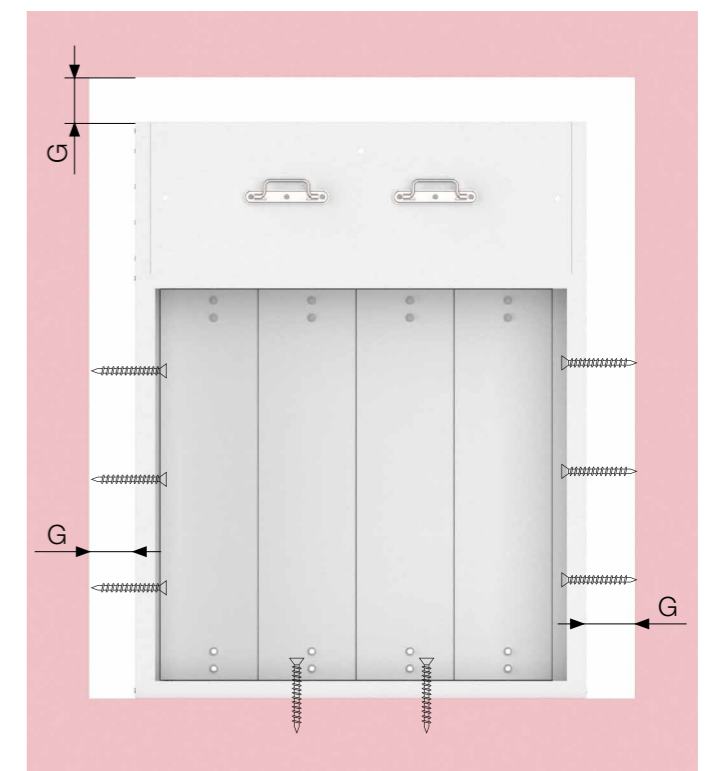
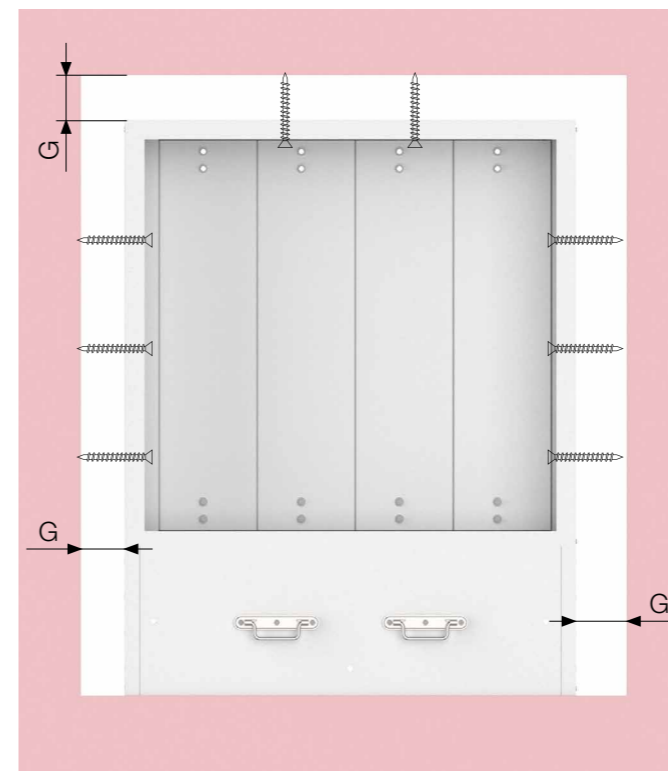
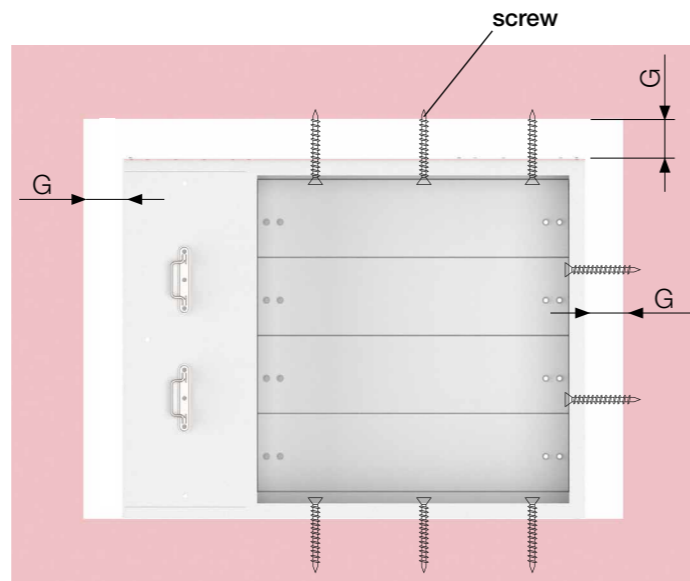
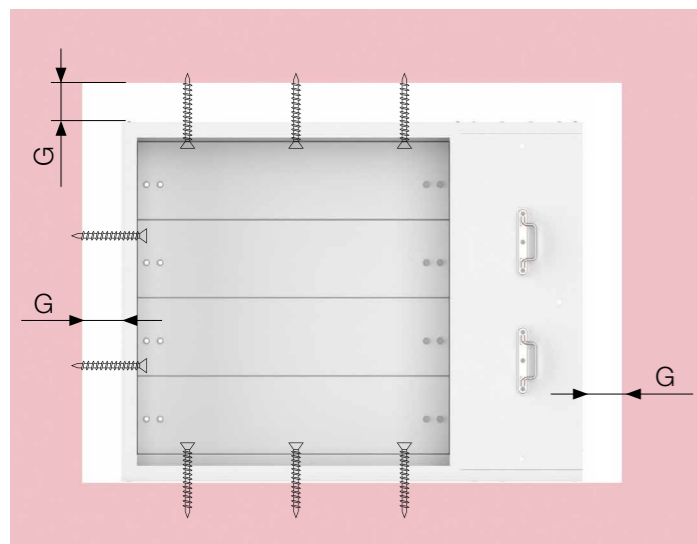

Gap (G)	Min.	Max.	Recomended
Mineral wool	50	150	100

FSD SMOKE CONTROL DAMPER

Aerated concrete wall installation

The wall is composed of aerated concrete (minimum density of 500 kg/m³), and with minimum thickness of 100 mm.

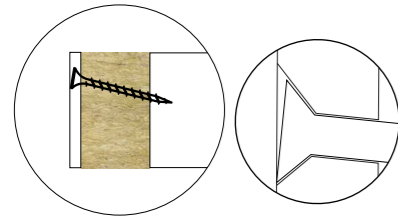

Screws are installed at an angle, fixed to the center of the wall.
Make sure the head of the screws doesn't interfere with the operation of the blades!



- ▼ [PRODUCT OVERVIEW](#)
- ▼ [DIMENSIONS](#)
- ▼ [INSTALLATIONS](#)
- ▼ [ACTUATORS](#)
- ▼ [ACCESSORIES](#)
- ▼ [MAINTENANCE AND OPERATION](#)



INSTALLATION

FSD SMOKE CONTROL DAMPER

1. Create a hole in the wall. Check the recommended wall opening and screw on sides on [page 10](#). Cover the bottom side of the hole with Promastop CC. Thickness of the coating should be about 2 mm.

2.a **FOR INSTALLATION WITH VERTICALLY ORIENTED BLADES:** Insert the damper into the wall so that the top or bottom side rests against the wall. **CAUTION:** Avoid leaning on the damper blades during installation! Drill holes on the bottom and top side, and on the side opposite the actuator. Fix the smoke damper to the wall using screws (6, of appropriate length). **CAUTION:** Make sure that the tightening force does not cause deformation of the housing!

2.b **FOR INSTALLATION WITH HORIZONTALLY ORIENTED BLADES:** Insert the damper into the wall so that the right or left side rests against the wall. **CAUTION:** Avoid leaning on the damper blades during installation! Drill holes on the right and left side, and on the side opposite the actuator. Fix the smoke damper to the wall using screws (6, of appropriate length). **CAUTION:** Make sure that the tightening force does not cause deformation of the housing!

Number of screws
6 top and bottom sides (B dimension)
200-500- 2 pcs.
550-850- 3 pcs.
900-1200- 4 pcs.

6 left sides (H dimension)
240-440- 1 pcs.
640-840-2 pcs.
1040-1240-3 pcs.
1440-1640- 4 pcs.
1840-2040- 5 pcs.

3. Fill the space between casing and wall with mineral wool (140 kg/m³) and seal all connections with Promastop CC (intumescent fire resistant sealant). Mineral wool and the connection between the damper and the mineral wool must be coated with one layer of fire protection coating.

Test the operation of the damper blades!
Remove corner supports after installation!

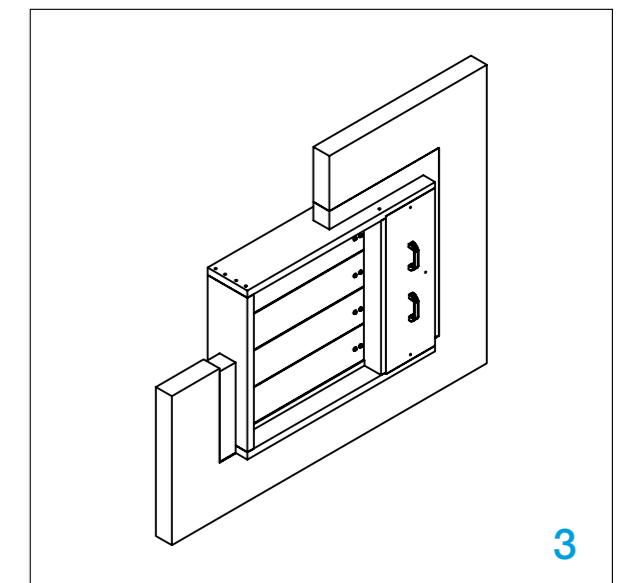
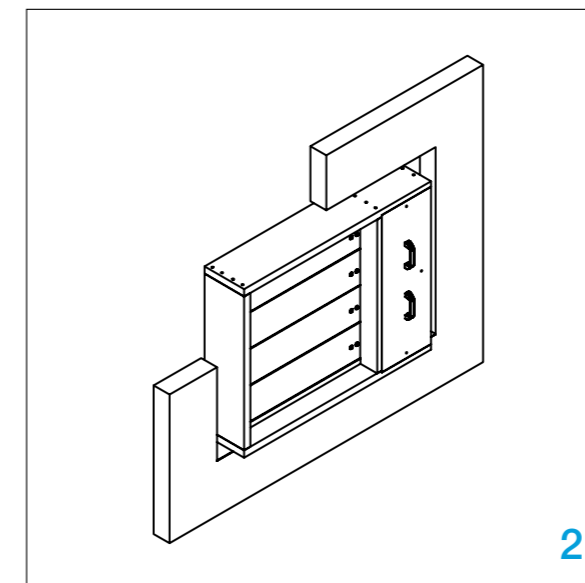
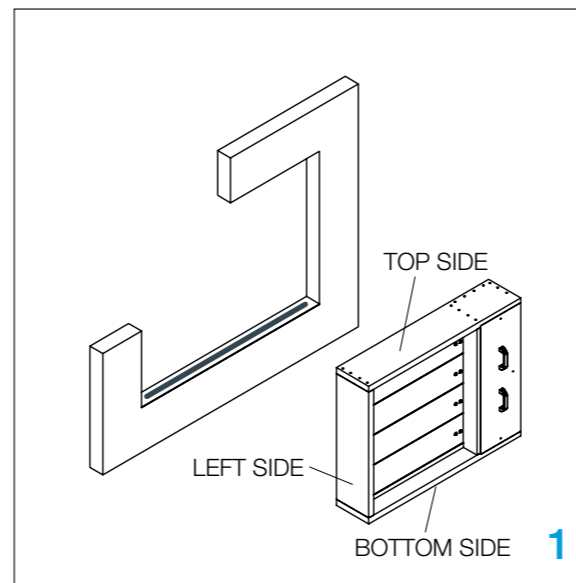

Rigid wall installation

The wall is composed of concrete (minimum density of 500 kg/m³) with a minimum thickness of 100 mm.

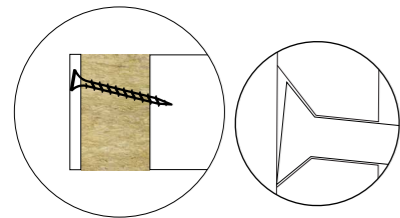

Screws are installed at an angle, fixed to the center of the wall.
Make sure the head of the screws doesn't interfere with the operation of the blades!



- ▼ [PRODUCT OVERVIEW](#)
- ▼ [DIMENSIONS](#)
- ▼ [INSTALLATIONS](#)
- ▼ [ACTUATORS](#)
- ▼ [ACCESSORIES](#)
- ▼ [MAINTENANCE AND OPERATION](#)



INSTALLATION

FSD SMOKE CONTROL DAMPER

1. Create a hole in the wall. Check the recommended wall opening and screw on sides on [page 10](#). Cover the bottom side of the hole with Promastop CC. Thickness of the coating should be about 2 mm.

2.a **FOR INSTALLATION WITH VERTICALLY ORIENTED BLADES:** Insert the damper into the wall so that the top or bottom side rests against the wall. **CAUTION:** Avoid leaning on the damper blades during installation! Drill holes on the bottom and top side, and on the side opposite the actuator. Fix the smoke damper to the wall using screws (6, of appropriate length). **CAUTION:** Make sure that the tightening force does not cause deformation of the housing!

2.b **FOR INSTALLATION WITH HORIZONTALLY ORIENTED BLADES:** Insert the damper into the wall so that the right or left side rests against the wall. **CAUTION:** Avoid leaning on the damper blades during installation! Drill holes on the right and left side, and on the side opposite the actuator. Fix the smoke damper to the wall using screws (6, of appropriate length). **CAUTION:** Make sure that the tightening force does not cause deformation of the housing!

Number of screws
6 top and bottom sides (B dimension)
200-500- 2 pcs.
550-850- 3 pcs.
900-1200- 4 pcs.

6 left sides (H dimension)
240-440- 1 pcs.
640-840-2 pcs.
1040-1240-3 pcs.
1440-1640- 4 pcs.
1840-2040- 5 pcs.

3. Fill the space between casing and wall with mineral wool (140 kg/m³) and seal all connections with Promastop CC (intumescent fire resistant sealant). Mineral wool and the connection between the damper and the mineral wool must be coated with one layer of fire protection coating.

Test the operation of the damper blades!
Remove corner supports after installation!

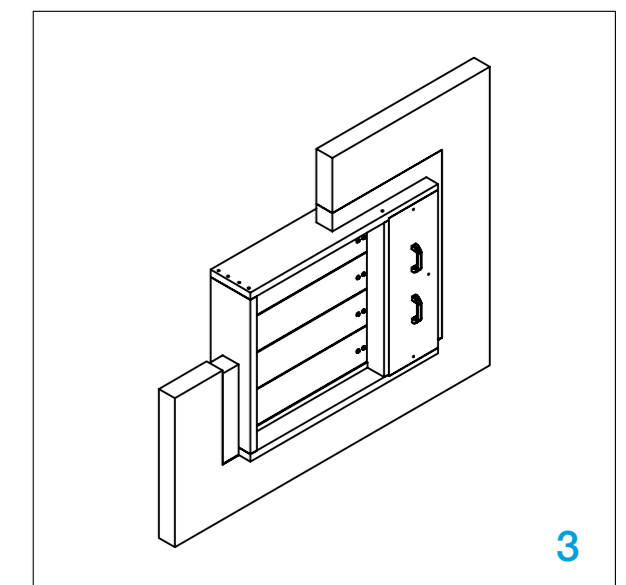
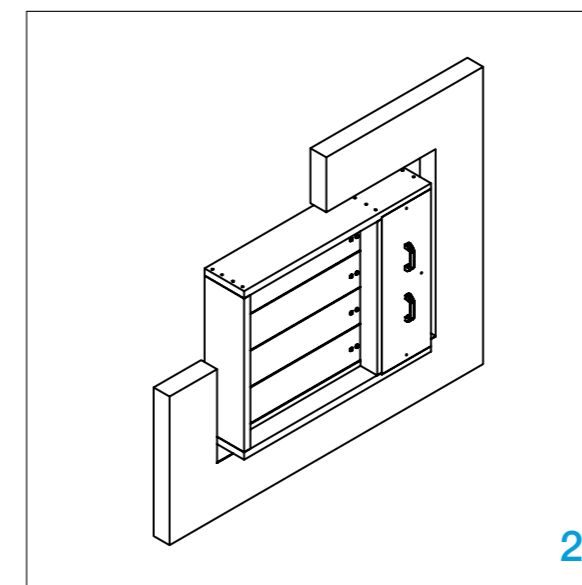
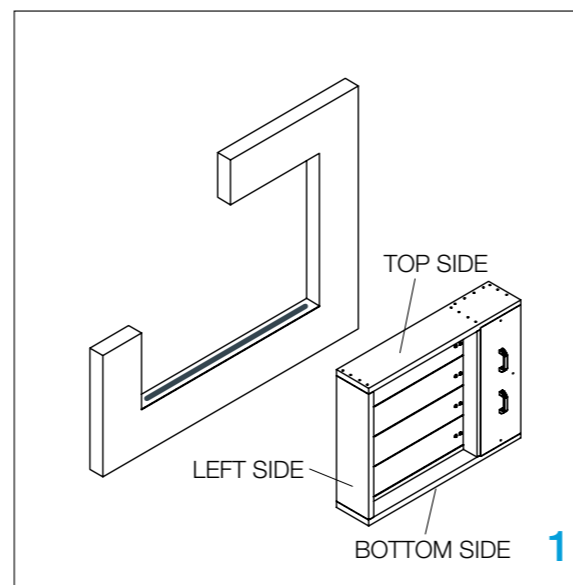

Brick wall installation

The wall is composed of brick blocks (minimum density of 500 kg/m³) with a minimum thickness of 100 mm.

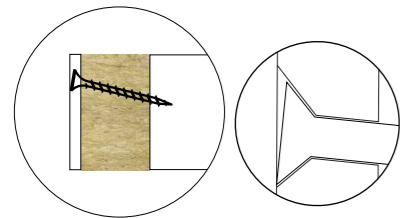

Screws are installed at an angle, fixed to the center of the wall. Make sure the head of the screws doesn't interfere with the operation of the blades!



- ▼ [PRODUCT OVERVIEW](#)
- ▼ [DIMENSIONS](#)
- ▼ [INSTALLATIONS](#)
- ▼ [ACTUATORS](#)
- ▼ [ACCESSORIES](#)
- ▼ [MAINTENANCE AND OPERATION](#)



INSTALLATION

FSD SMOKE CONTROL DAMPER

1. Create a hole in the wall. Check the recommended wall opening and screw on sides on [page 10](#). Cover the bottom side of the hole with Promastop CC. Thickness of the coating should be about 2 mm.

2.a **FOR INSTALLATION WITH VERTICALLY ORIENTED BLADES:** Insert the damper into the wall so that the top or bottom side rests against the wall. **CAUTION:** Avoid leaning on the damper blades during installation! Drill holes on the bottom and top side, and on the side opposite the actuator. Fix the smoke damper to the wall using screws (6, of appropriate length). **CAUTION:** Make sure that the tightening force does not cause deformation of the housing!

2.b **FOR INSTALLATION WITH HORIZONTALLY ORIENTED BLADES:** Insert the damper into the wall so that the right or left side rests against the wall. **CAUTION:** Avoid leaning on the damper blades during installation! Drill holes on the right and left side, and on the side opposite the actuator. Fix the smoke damper to the wall using screws (6, of appropriate length). **CAUTION:** Make sure that the tightening force does not cause deformation of the housing!

Number of screws
6 top and bottom sides (B dimension)
 200-500- 2 pcs.
 550-850- 3 pcs.
 900-1200- 4 pcs.

6 left sides (H dimension)
 240-440- 1 pcs.
 640-840-2 pcs.
 1040-1240-3 pcs.
 1440-1640- 4 pcs.
 1840-2040- 5 pcs.

3. Fill the space between casing and wall with mineral wool (140 kg/m³) and seal all connections with Promastop CC (intumescent fire resistant sealant). Mineral wool and the connection between the damper and the mineral wool must be coated with one layer of fire protection coating.

Test the operation of the damper blades!
Remove corner supports after installation!

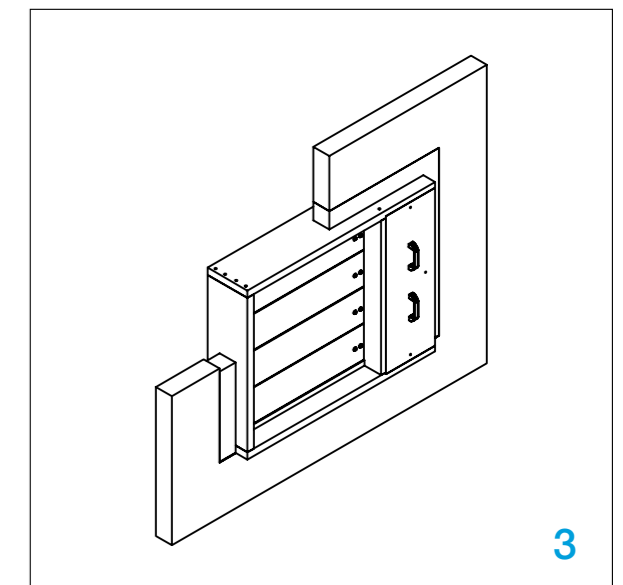
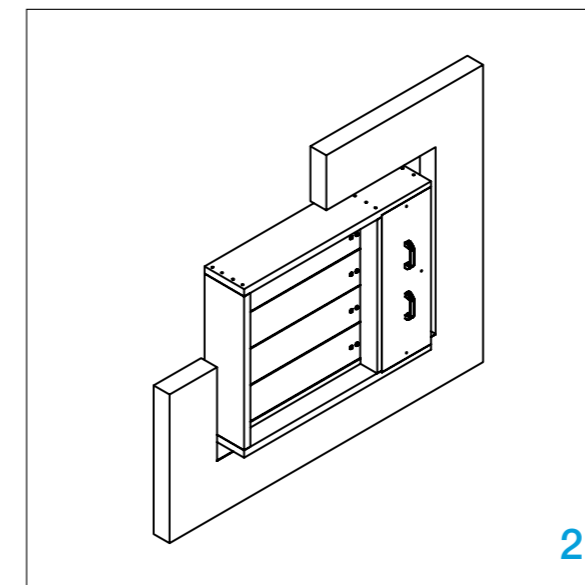
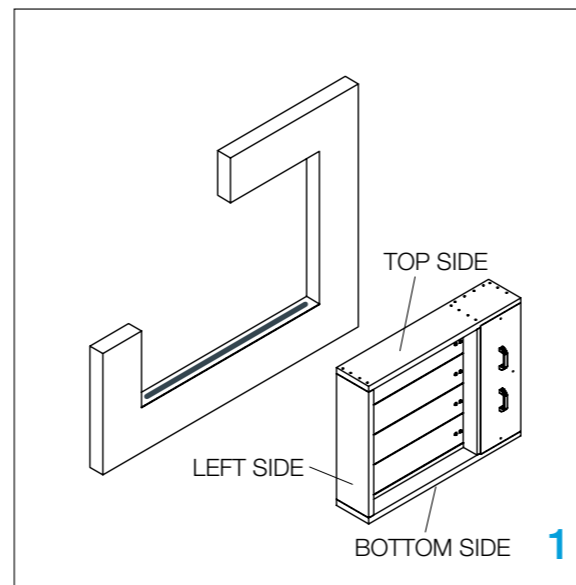

Flexible wall with type F gypsum plasterboards installation

The wall is composed of 2x2 plasterboard boards, 12,5 mm thick, installed on a steel frame construction.

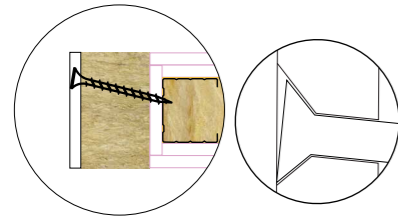

Screws are installed at an angle, fixed to the center of metal frame of the wall. Make sure the head of the screws doesn't interfere with the operation of the blades!

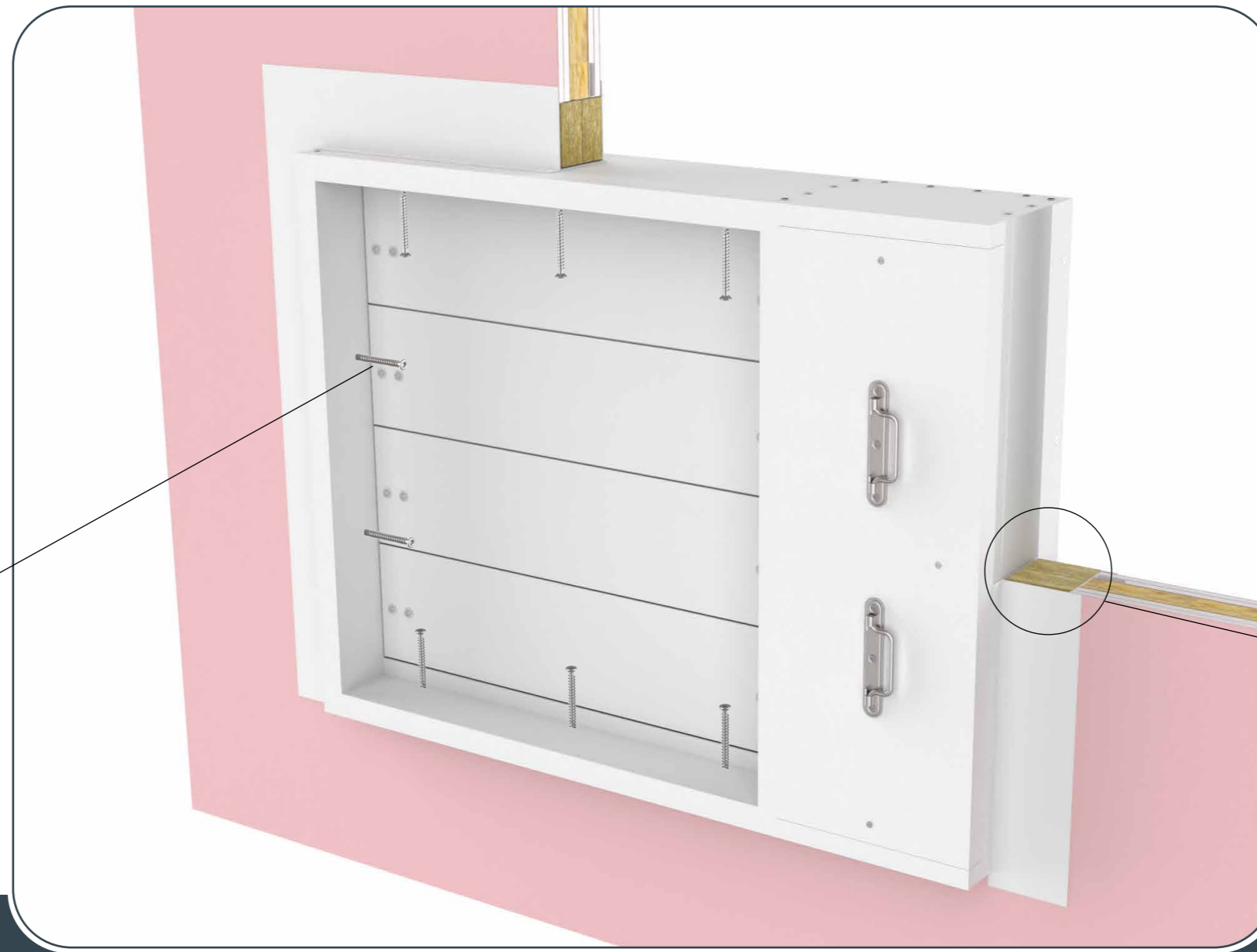

- ▼ [PRODUCT OVERVIEW](#)
- ▼ [DIMENSIONS](#)
- ▼ [INSTALLATIONS](#)
- ▼ [ACTUATORS](#)
- ▼ [ACCESSORIES](#)
- ▼ [MAINTENANCE AND OPERATION](#)

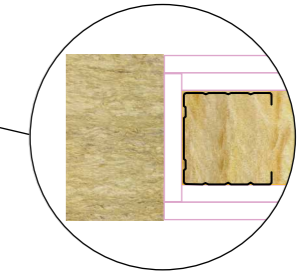

Detail of the opening in flexible wall



INSTALLATION

FSD SMOKE CONTROL DAMPER

1. Create a hole in the wall. Check the recommended wall opening and screw on sides on [page 10](#), and build a subframe (drawing 1). Cover the bottom side of the hole with with Promastop CC. Thickness of the coating should be about 2 mm.

2.a **FOR INSTALLATION WITH VERTICALLY ORIENTED BLADES:** Insert the damper into the wall so that the top or bottom side rests against the wall. **CAUTION:** Avoid leaning on the damper blades during installation! Drill holes on the bottom and top side, and on the side opposite the actuator. Fix the smoke damper to the wall using screws (6, of appropriate length). **CAUTION:** Make sure that the tightening force does not cause deformation of the housing!

2.b **FOR INSTALLATION WITH HORIZONTALLY ORIENTED BLADES:** Insert the damper into the wall so that the right or left side rests against the wall. **CAUTION:** Avoid leaning on the damper blades during installation! Drill holes on the right and left side, and on the side opposite the actuator. Fix the smoke damper to the wall using screws (6, of appropriate length). **CAUTION:** Make sure that the tightening force does not cause deformation of the housing!

3. Insert the damper into the wall so that the bottom side rests against the wall. **CAUTION:** Avoid leaning on the flap slats during installation! Drill holes on the bottom and top sides, and on the vertical side opposite the actuator. Fix the smoke damper to the wall using screws (6, of appropriate length). **CAUTION:** Make sure that the tightening force does not cause deformation of the housing!

Number of screws

6 top and bottom sides (B dimension)
200-500 -2 pcs.
550-850 -3 pcs.
900-1200- 4 pcs.

6 left sides (H dimension)

240-440 -1 pcs.
640-840 -2 pcs.
1040-1240 -3 pcs.
1440-1640 -4 pcs.
1840-2040 -5 pcs.

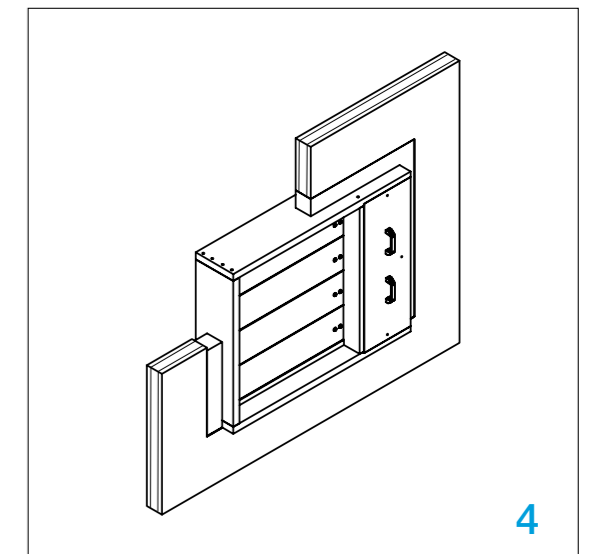
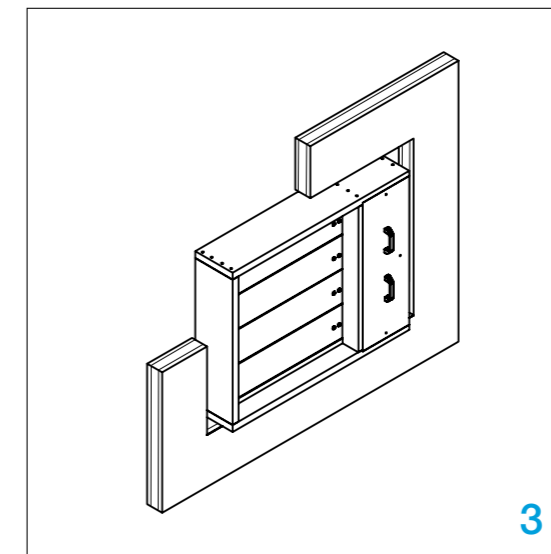
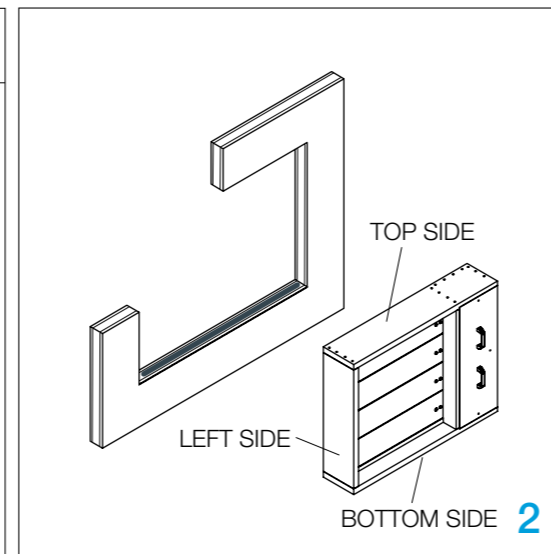
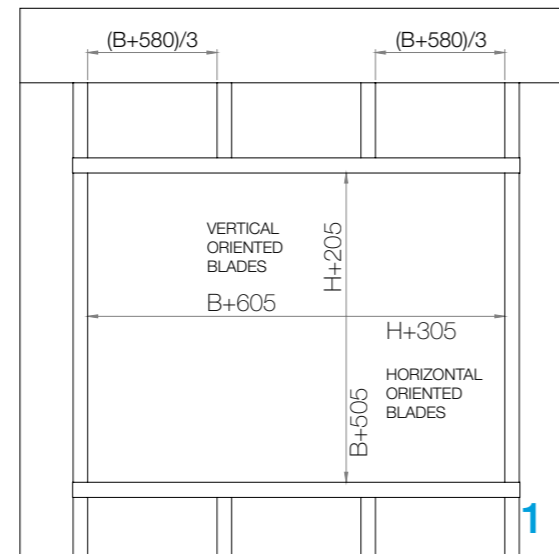

4. Fill the space between casing and wall with mineral wool (140 kg/m³) and seal all connections with Promastop CC (intumescent fire resistant sealant). Mineral wool and the connection between the damper and the mineral wool must be coated with one layer of fire protection coating.

Test the operation of the damper blades!
Remove corner supports after installation!

Horizontal duct installation

Smoke damper smaller than duct

Duct is defined as a fire resistant smoke extract duct, with wall thickness ≥ 35 mm. Duct is tested according EN1366-8 or EN1366-9, with density $\rho \geq 500$ kg/m³.



- ▼ [PRODUCT OVERVIEW](#)
- ▼ [DIMENSIONS](#)
- ▼ [INSTALLATIONS](#)
- ▼ [ACTUATORS](#)
- ▼ [ACCESSORIES](#)
- ▼ [MAINTENANCE AND OPERATION](#)



INSTALLATION

FSD SMOKE CONTROL DAMPER

1. Create an installation opening according to drawing.
2. Fix the bottom fire rated boards to the duct first, to create the underside for the smoke damper to sit on.
3. Place the smoke control damper in front of the installation opening. If necessary, support the damper.
4. Fix the rest of the fire rated boards according to the drawings.

Test the operation of the damper blades!

All connection must be covered with Promat Kleber K84 or similar glue!

Duct and damper must be suspended separately. Damper must not bear the weight of the duct and vice versa.

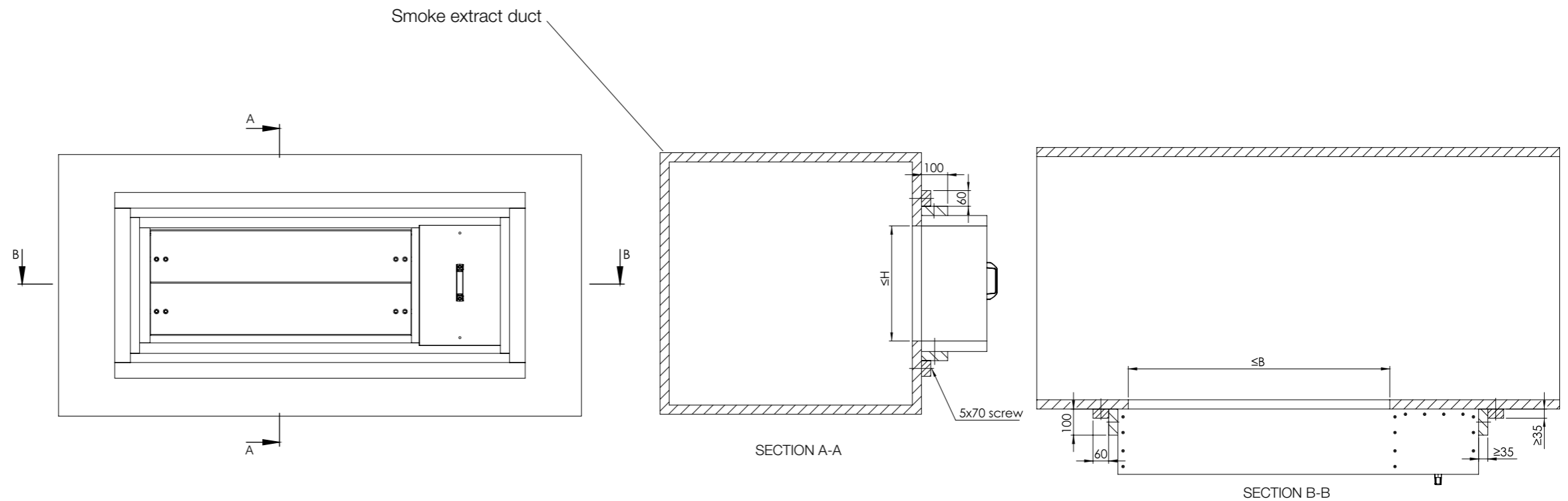

Horizontal duct installation

Smoke damper in the middle of the duct

Duct is defined as a fire resistant smoke extract duct, with wall thickness ≥ 35 mm. Duct is tested according EN1366-8 or EN1366-9, with density $\rho \geq 500\text{kg/m}^3$.

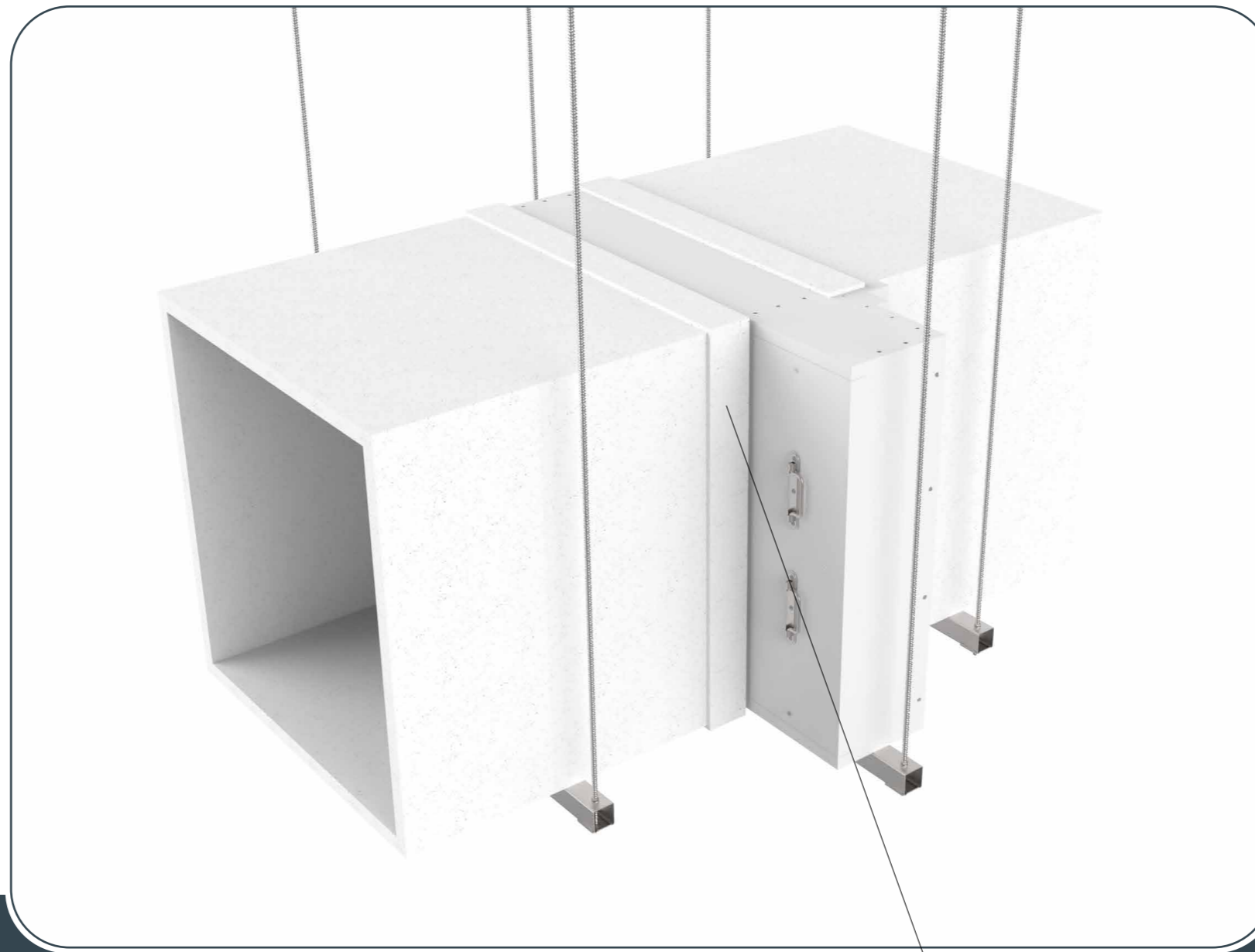

- ▼ [PRODUCT OVERVIEW](#)
- ▼ [DIMENSIONS](#)
- ▼ [INSTALLATIONS](#)
- ▼ [ACTUATORS](#)
- ▼ [ACCESSORIES](#)
- ▼ [MAINTENANCE AND OPERATION](#)



INSTALLATION

FSD SMOKE CONTROL DAMPER

1. Create an installation opening according to drawing.
2. Fix the bottom fire rated boards to the duct, to create the underside for the smoke damper to sit on.
3. Place the smoke control damper in front of the installation opening. Support the damper.
4. Fix the rest of the fire rated boards according to the drawings.

Test the operation of the damper blades!

All connection must be covered with Promat Kleber K84 or similar glue!

Duct and damper must be suspended separately. Damper must not bear the weight of the duct and vice versa.

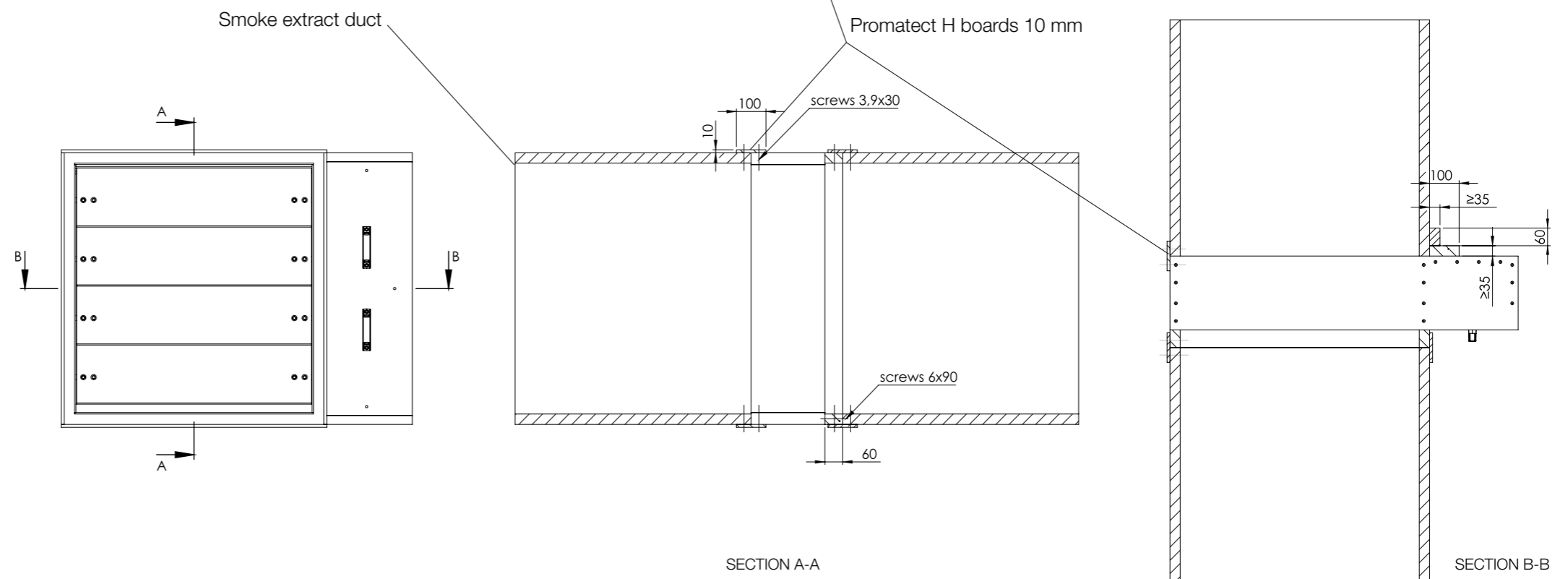

Horizontal duct installation

Smoke damper on the end of the duct

Duct is defined as a fire resistant smoke extract duct, with wall thickness ≥ 35 mm. Duct is tested according EN1366-8 or EN1366-9, with density $\rho \geq 500\text{kg/m}^3$.



- ▼ [PRODUCT OVERVIEW](#)
- ▼ [DIMENSIONS](#)
- ▼ [INSTALLATIONS](#)
- ▼ [ACTUATORS](#)
- ▼ [ACCESSORIES](#)
- ▼ [MAINTENANCE AND OPERATION](#)



INSTALLATION

FSD SMOKE CONTROL DAMPER

1. Create an installation opening according to drawing.
2. Fix the bottom fire rated boards to the duct, to create the underside for the smoke damper to sit on.
3. Place the smoke control damper in front of the installation opening. Support the damper.
4. Fix the rest of the fire rated boards according to the drawings.

Test the operation of the damper blades!

All connection must be covered with Promat Kleber K84 or similar glue!

Duct and damper must be suspended separately. Damper must not bear the weight of the duct and vice versa.

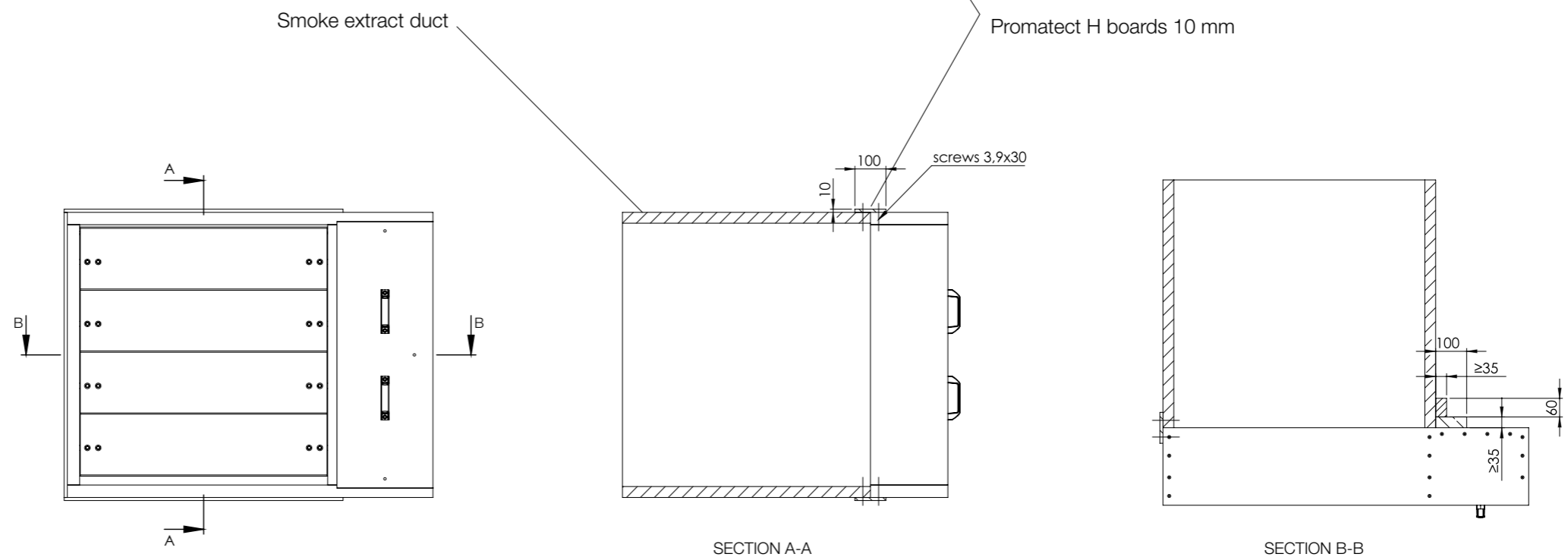

Horizontal duct installation

Smoke damper smaller than duct

Duct is defined as a fire resistant smoke extract duct, with wall thickness ≥ 35 mm. Duct is tested according EN1366-8 or EN1366-9, with density $\rho \geq 500\text{kg/m}^3$.

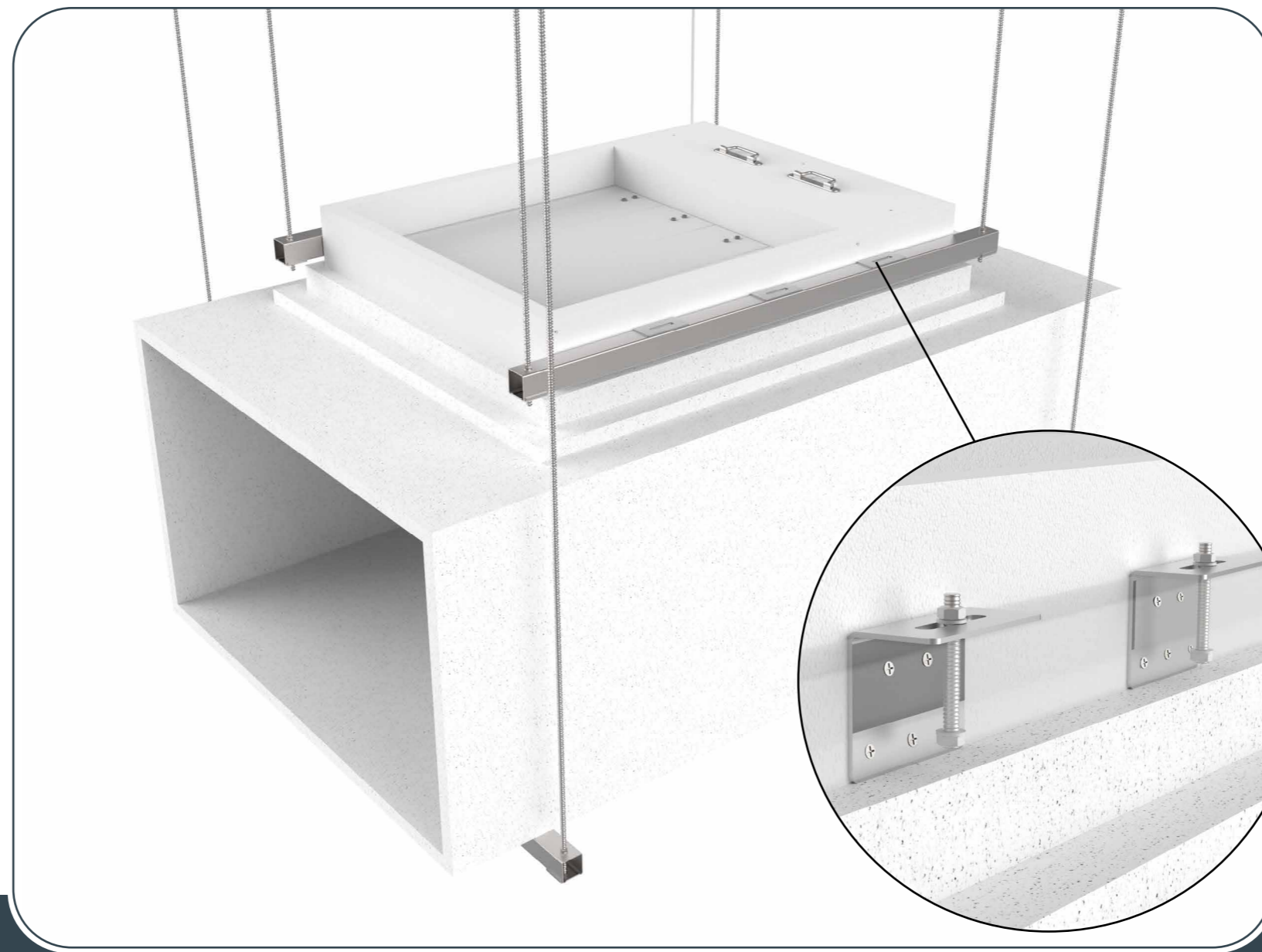

- ▼ [PRODUCT OVERVIEW](#)
- ▼ [DIMENSIONS](#)
- ▼ [INSTALLATIONS](#)
- ▼ [ACTUATORS](#)
- ▼ [ACCESSORIES](#)
- ▼ [MAINTENANCE AND OPERATION](#)



INSTALLATION

FSD SMOKE CONTROL DAMPER

1. Create an installation opening according to drawing.
2. Place the smoke control damper on top of the installation opening. Support the damper with additional L profiles. Install suspension with drywall screws.
3. Fix the rest of the fire rated boards according to the drawings.

[See page 26.](#)

Test the operation of the damper blades!

All connection must be covered with Promat Kleber K84 or similar glue!

Duct and damper must be suspended separately. Damper must not bear the weight of the duct and vice versa.

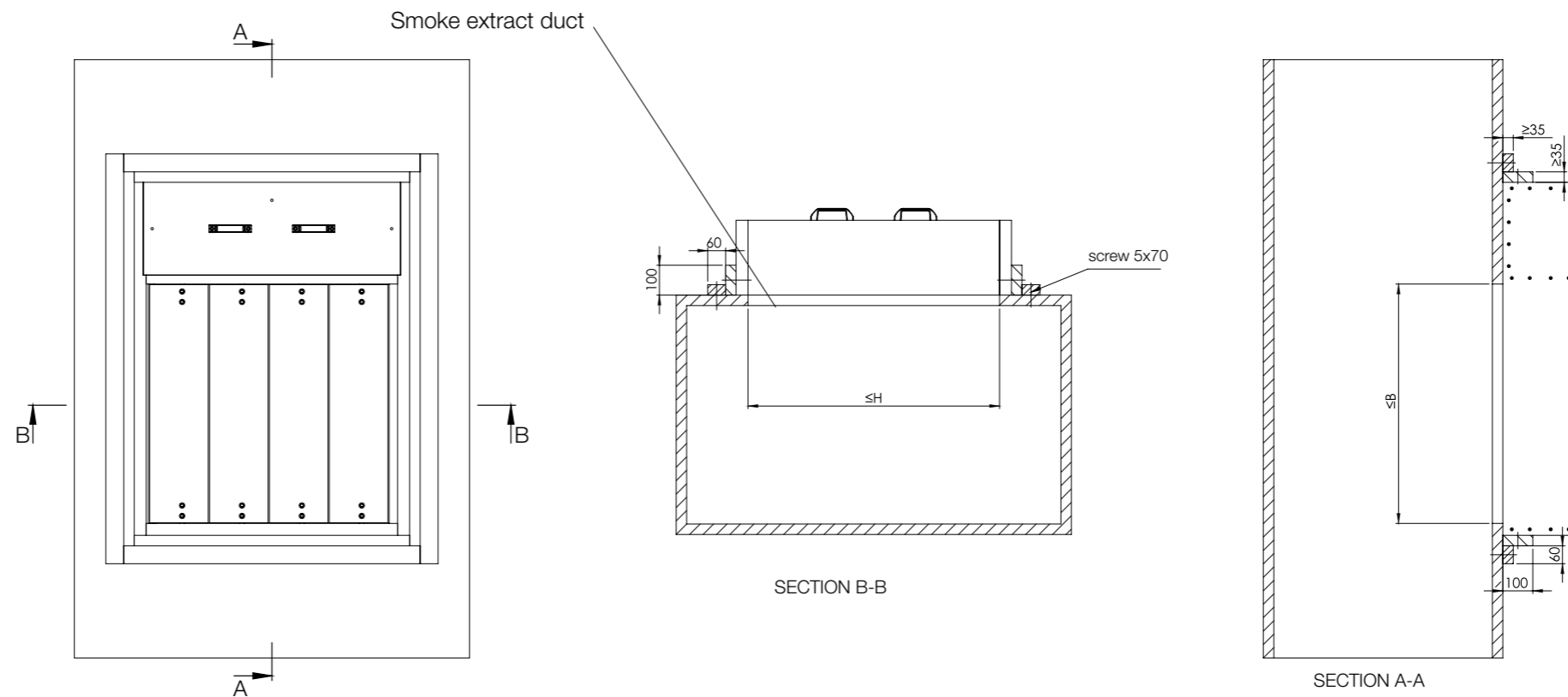

Vertical duct installation

Smoke damper smaller than duct

Duct is defined as a fire resistant smoke extract duct, with wall thickness ≥ 35 mm. Duct is tested according EN1366-8 or EN1366-9, with density $\rho \geq 500\text{kg/m}^3$.



- ▼ [PRODUCT OVERVIEW](#)
- ▼ [DIMENSIONS](#)
- ▼ [INSTALLATIONS](#)
- ▼ [ACTUATORS](#)
- ▼ [ACCESSORIES](#)
- ▼ [MAINTENANCE AND OPERATION](#)



INSTALLATION

FSD SMOKE CONTROL DAMPER

1. Create an installation opening according to drawing.
2. Fix the bottom fire rated boards to the duct first, to create the underside for the smoke damper to sit on.
3. Place the smoke control damper in front of the installation opening. Support the damper.
4. Fix the rest of the fire rated boards according to the drawings.

Test the operation of the damper blades!

All connection must be covered with Promat Kleber K84 or similar glue!

Duct and damper must be suspended separately. Damper must not bear the weight of the duct and vice versa.

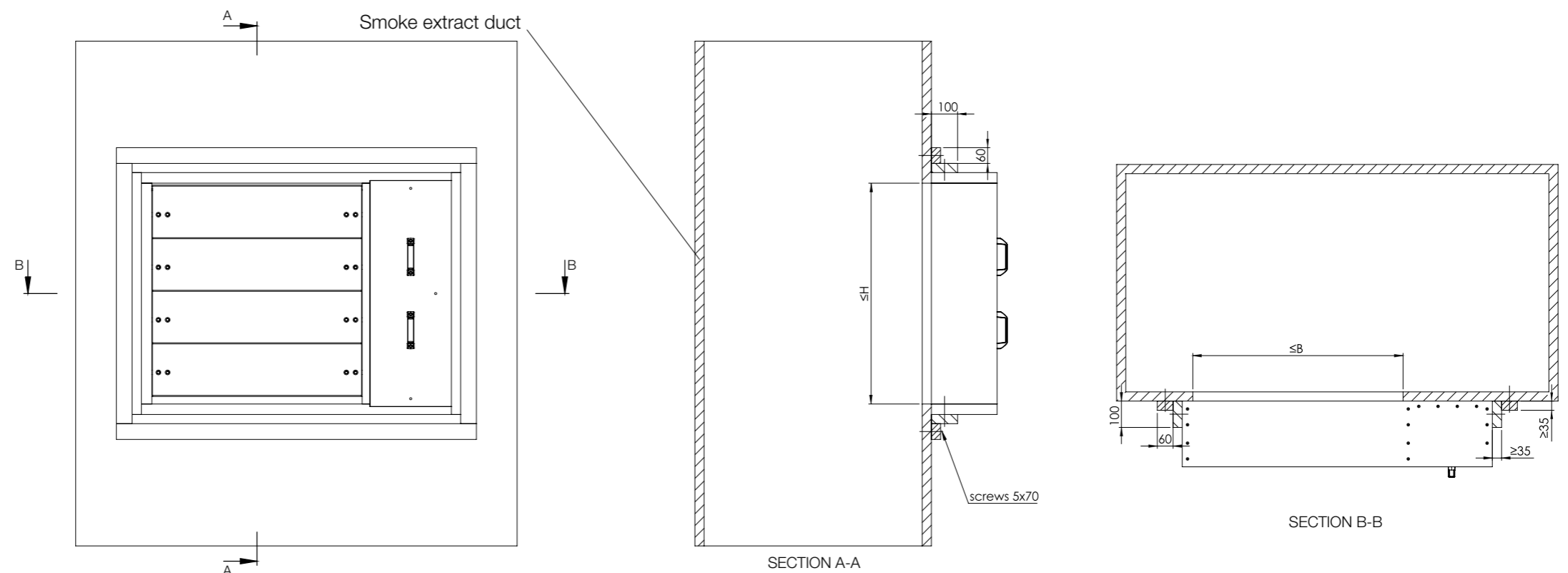

Vertical duct installation

Smoke damper bigger than duct

Duct is defined as a fire resistant smoke extract duct, with wall thickness ≥ 35 mm. Duct is tested according EN1366-8 or EN1366-9, with density $\rho \geq 500\text{kg/m}^3$.



- ▼ [PRODUCT OVERVIEW](#)
- ▼ [DIMENSIONS](#)
- ▼ [INSTALLATIONS](#)
- ▼ [ACTUATORS](#)
- ▼ [ACCESSORIES](#)
- ▼ [MAINTENANCE AND OPERATION](#)



INSTALLATION

FSD SMOKE CONTROL DAMPER

1. Create an installation opening according to drawing.
2. Fix the bottom fire rated boards to the duct first, to create the underside for the smoke damper to sit on.
3. Place the smoke control damper in front of the installation opening. Support the damper.
4. Fix the rest of the fire rated boards according to the drawings.

Test the operation of the damper blades!

All connection must be covered with Promat Kleber K84 or similar glue!

Duct and damper must be suspended separately. Damper must not bear the weight of the duct and vice versa.

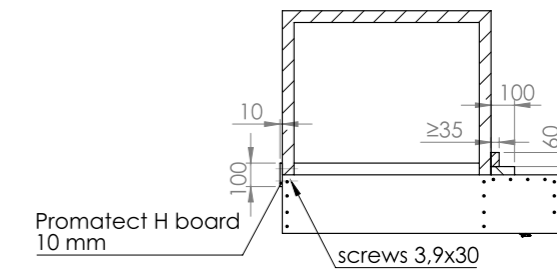
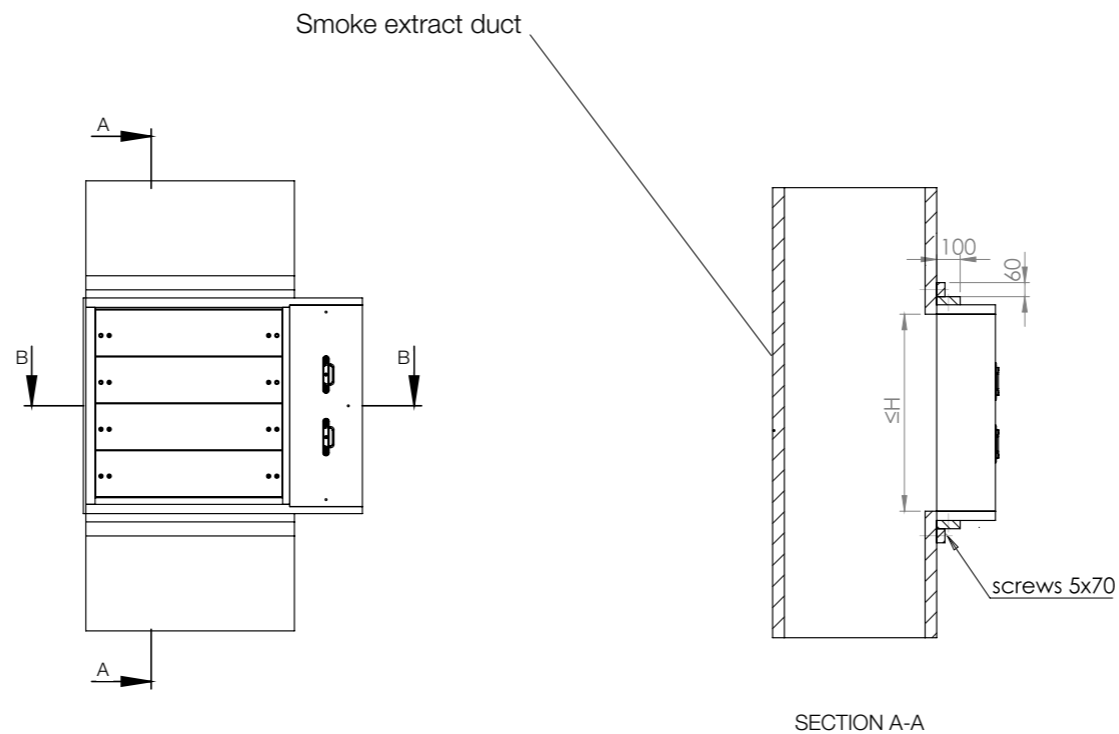

Minimal installation distances

● Mineral wool (140 kg/m³)

Smoke control damper can be installed with minimal distance of 75 mm between wall/ceiling and 200 mm from other dampers.

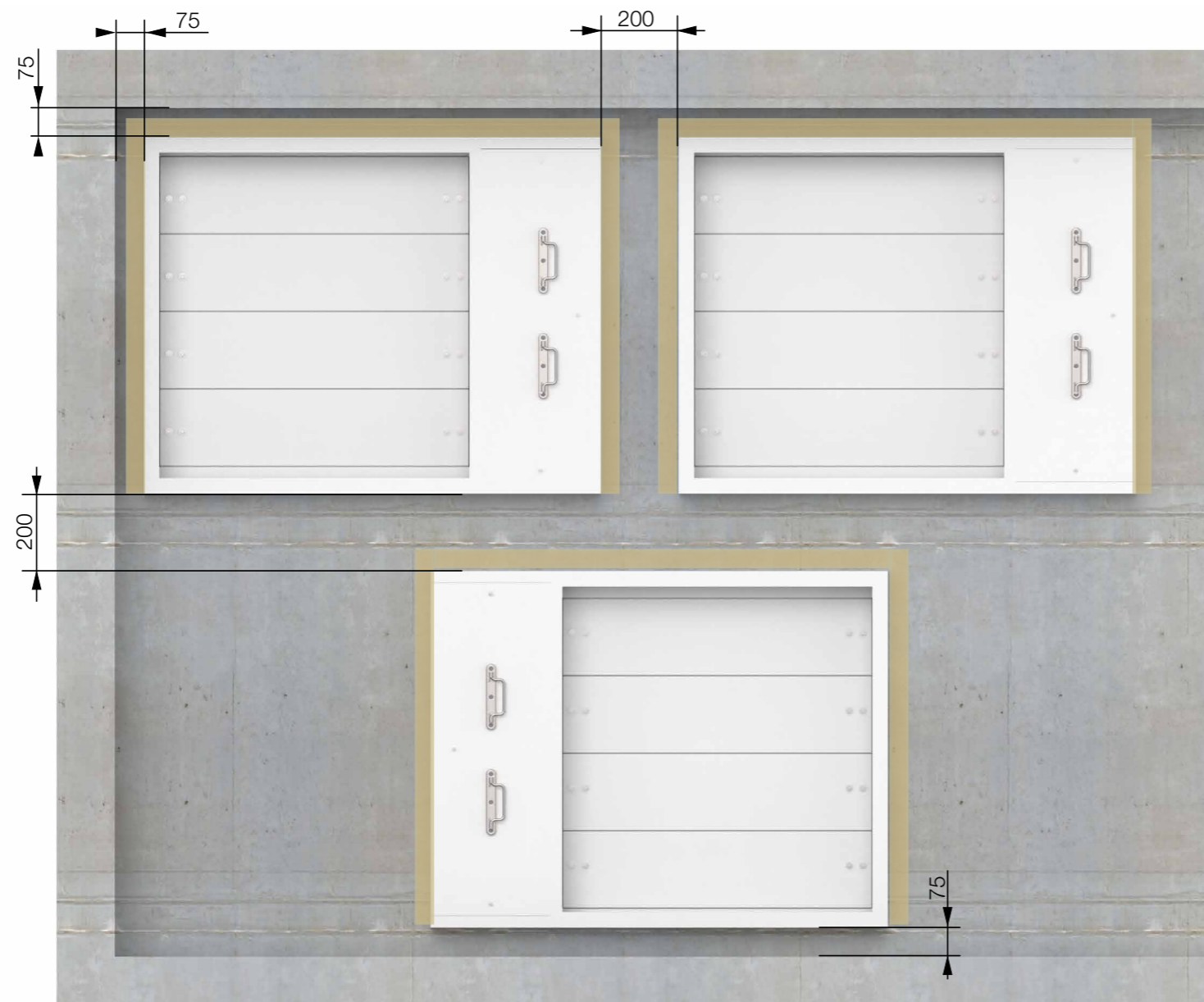

*Minimal distances from another damper or wall/ceiling.

- ▼ [PRODUCT OVERVIEW](#)
- ▼ [DIMENSIONS](#)
- ▼ [INSTALLATIONS](#)
- ▼ [ACTUATORS](#)
- ▼ [ACCESSORIES](#)
- ▼ [MAINTENANCE AND OPERATION](#)

 INSTALLATION

FSD SMOKE CONTROL DAMPER

ELECTRIC ACTUATOR

BEN 24 V, BEN 230 V,
BEE 24 V, BEE 230 V,
BE 24 V, BE 230 V

Damper is delivered in closed position. The actuator features 2-wire open/close control. Actuator is overload proof and can remain energized at the end stops. Safety position lock enables the actuator to hold the damper in the defined safety position in case of fire. Two microswitches with fixed settings are installed in the actuator for indicating the damper end positions. It should be noted in this application, however that the contacts can no longer be used in the milliamperere range after larger currents have been applied to them, even if this has taken place only once. The position of the damper blade can be read off on a mechanical position indication. Manual operation is possible with the hand crank that is provided with the actuator.



- ▼ [PRODUCT OVERVIEW](#)
- ▼ [DIMENSIONS](#)
- ▼ [INSTALLATIONS](#)
- ▼ [ACTUATORS](#)
- ▼ [ACCESSORIES](#)
- ▼ [MAINTENANCE AND OPERATION](#)

Wiring diagram

AC 230 V, open-close

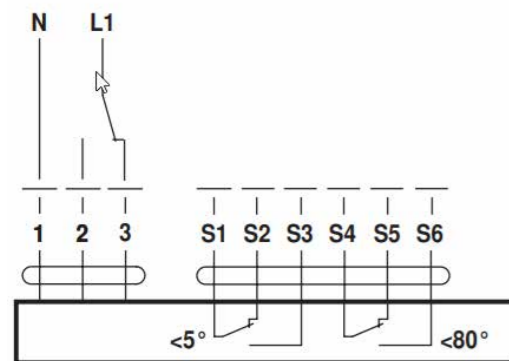

Cable colours:

- 1 = blue
- 2 = brown
- 3 = white

- S1 = violet
- S2 = red
- S3 = white
- S4 = orange
- S5 = pink
- S6 = grey

AC/DC 24 V, open-close

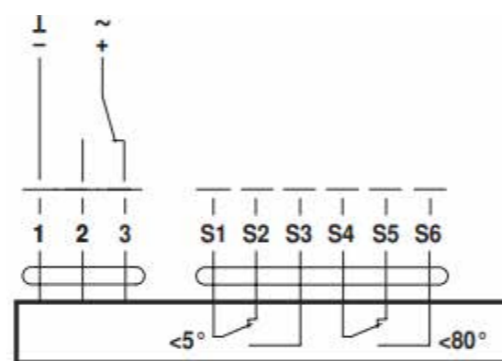

Cable colours:

- 1 = black
- 2 = red
- 3 = white

- S1 = violet
- S2 = red
- S3 = white
- S4 = orange
- S5 = pink
- S6 = grey

AC/DC 24 V, modulating

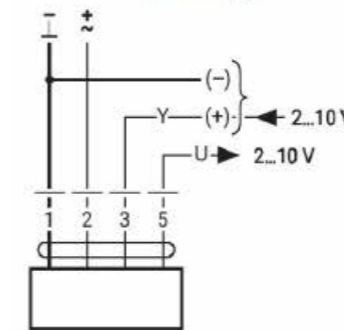

Auxiliary switch

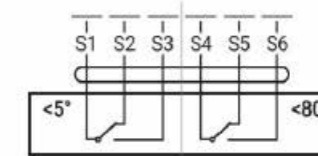

Cable colours:

- 1 = black
- 2 = red
- 3 = white
- 5 = orange

- S1 = violet
- S2 = red
- S3 = white
- S4 = orange
- S5 = pink
- S6 = grey

COMMUNICATION MODULES

FSD smoke dampers can be used with the following communication modules:

Belimo BKNE 230-24

The BKNE230-24 is a decentralised power supply unit for the BE24-ST, BLE24-ST, BEE24-ST or BEN24-ST smoke control damper actuators. It serves as a communication interface between the smoke control damper actuator and the BKSE24-6 communication and control unit.

Link to complete [technical documentation](#).



Bustec RBFU 2.01 ST

Field unit for 1 smoke control damper. Connects 1 smoke control damper to the Bustec Ringbus. Provides a plug connection for the Belimo BE24.-ST and BLE24-ST actuators. It has a predefined address (no addressing required during system commissioning). Powered with AC 230 V mains power.

Link to complete [technical documentation](#).



Agnosys BRM-10-F/BRM-10-S

- BRM-10-S fire smoke damper module IP20 for 35 mm DIN rail mounting
- BRM-10-F fire smoke damper module IP20 for wall mounting

The modules are used for monitoring, controlling and runtime testing of Fire smoke dampers. Communication with the higher-level control unit takes place via the Modbus/RTU protocol.

- Fully automatic test of the fire smoke actuators
- In the event of an error or communication failure, the relay output remains in the last switching position
- Operation of up to 63 modules per bus ring system over a maximum length of 900 m
- Redundant supply with 2 x 24 V DC voltage in the ring and 230 VAC via the valve supply
- Reverse polarity protected supply of the bus ring.
- Simple connection with spring-loaded terminals.

Link to complete [technical documentation](#).



- ▼ [PRODUCT OVERVIEW](#)
- ▼ [DIMENSIONS](#)
- ▼ [INSTALLATIONS](#)
- ▼ [ACTUATORS](#)
- ▼ [ACCESSORIES](#)
- ▼ [MAINTENANCE AND OPERATION](#)

FSD SMOKE CONTROL DAMPER

Wiring positions

- ▼ [PRODUCT OVERVIEW](#)
- ▼ [DIMENSIONS](#)
- ▼ [INSTALLATIONS](#)
- ▼ [ACTUATORS](#)
- ▼ [ACCESSORIES](#)
- ▼ [MAINTENANCE AND OPERATION](#)

FSD SMOKE CONTROL DAMPER

Electric cables and system

For manual release (MA), the electric cables and system must have at least 30 minutes circuit integrity. Depending on where a damper is installed, country-specific regulations may apply.

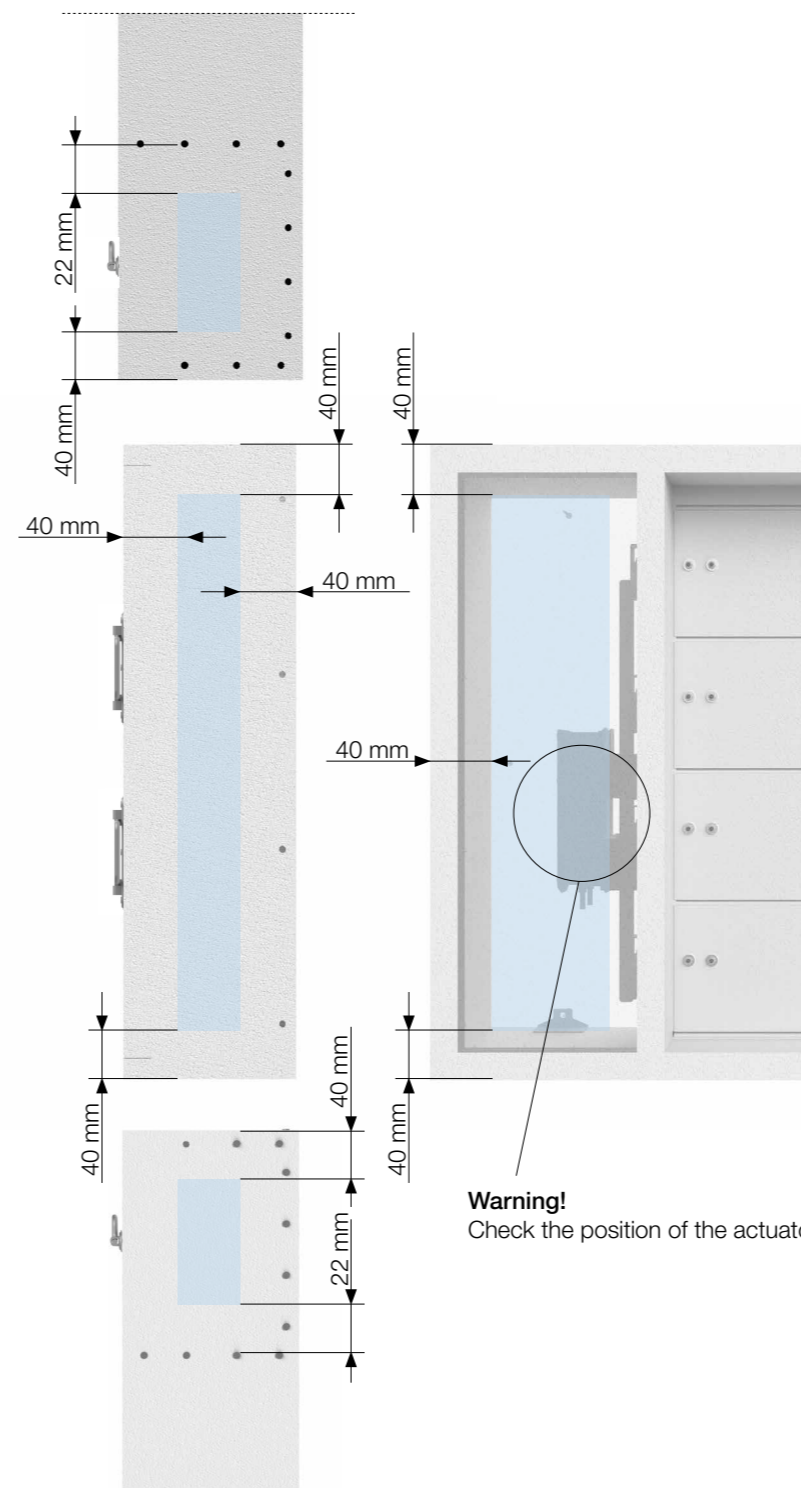
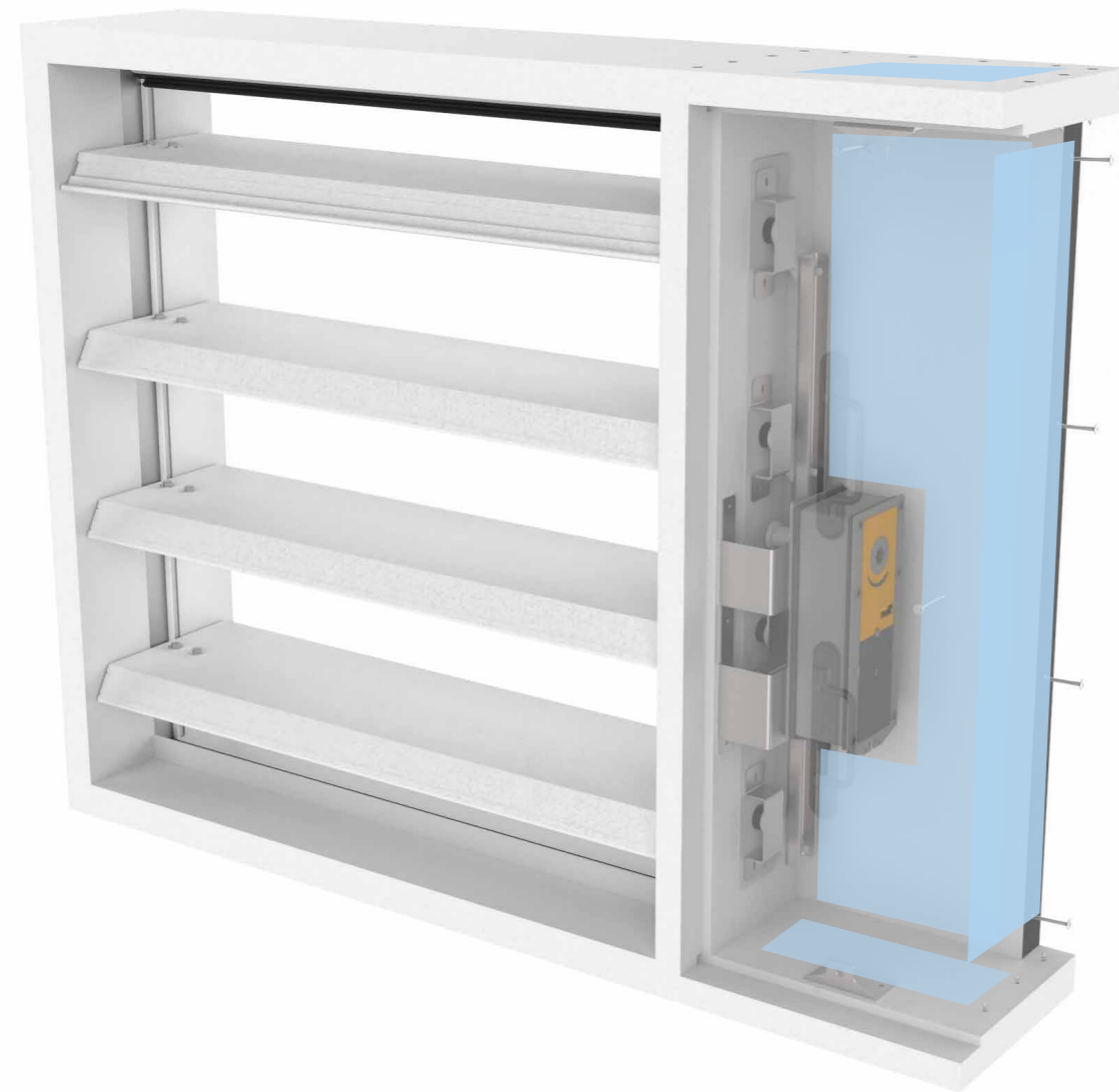

Drilling areas for routing the connection cable to the actuator

1. Drill size according to the connection cable $\phi+2$ mm
2. Pull the heat resistant cable through the calcium silicate casing and connect with cables from actuator
3. Seal up the space around the cable with fire resistant mastic (Promastop or similar)



Danger of electric shock!

Do not touch any live components!

Electrical equipment carries a dangerous electrical voltage.

- Only skilled qualified electricians are allowed to work on the electrical system.
- Switch off the power supply before working on any electrical equipment.

ACCESSORIES

A Safety grilles - Cover grilles (OAC, GG1, GG2) are available as an accessory to protect the smoke damper when it is installed without connection to a duct. Smoke control damper, safety grille if applicable, extension piece are assembled at the factory to form a unit. The free cross sectional area of the cover grille is 60% or more.

B Steel duct connection frame - SDC connection frame for steel ducts. After installation seal the connection with fire resistant mastic (Promastop, Hilti cfs-s acr)

C Suspension bracket for horizontal installation - L profiles for horizontal duct installation

D Communication plate with cable holder

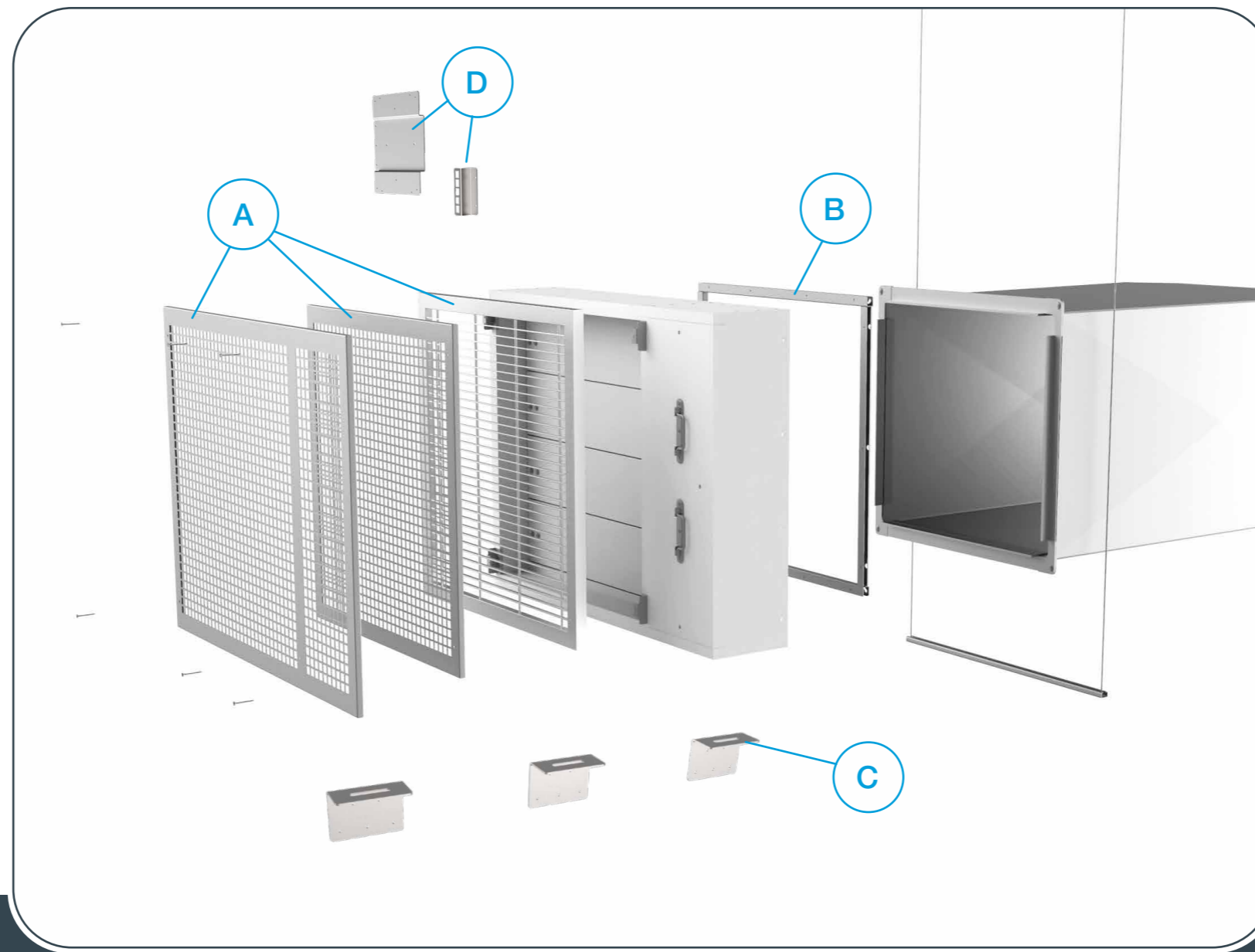

- ▼ [PRODUCT OVERVIEW](#)
- ▼ [DIMENSIONS](#)
- ▼ [INSTALLATIONS](#)
- ▼ [ACTUATORS](#)
- ▼ [ACCESSORIES](#)
- ▼ [MAINTENANCE AND OPERATION](#)

Accessories ordering key

(1) Type (2) Accessories (3) Dimension

FSD-A - SDC - BxH

(1) **FSD-A** - Accessories for smoke control smoke damper

- (2) **OAC** - Aluminium safety grill covering blades of the smoke damper
GG1 - Galvanised safety grill covering blades of the smoke damper
GG2 - Galvanised safety grill covering whole smoke damper
SDC - Steel duct connection frame
BHI - Suspension bracket for horizontal duct
HCM - Communication plate with cable holder

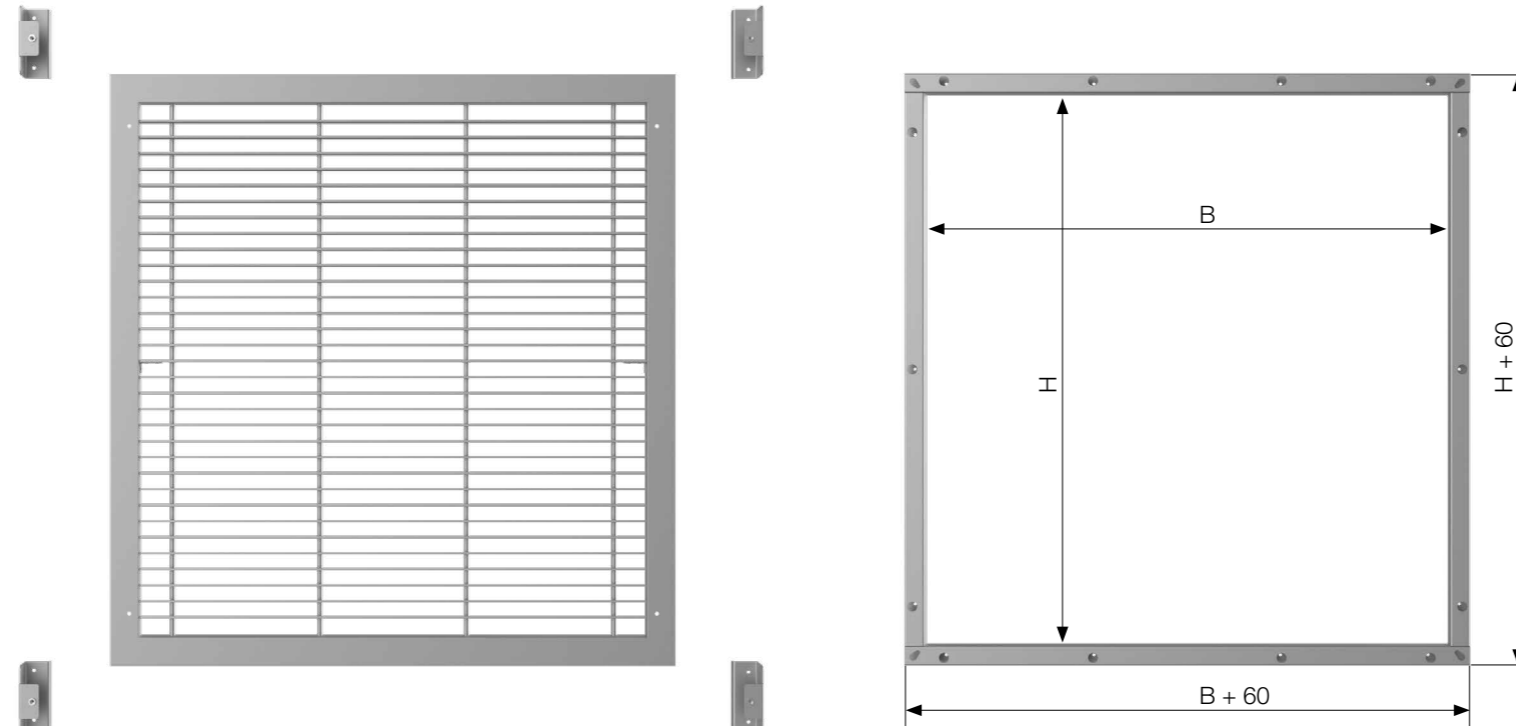

- ▼ [PRODUCT OVERVIEW](#)
- ▼ [DIMENSIONS](#)
- ▼ [INSTALLATIONS](#)
- ▼ [ACTUATORS](#)
- ▼ [ACCESSORIES](#)
- ▼ [MAINTENANCE AND OPERATION](#)

Safety grill installation

Install grill mounts in the corners of the smoke damper with 3,5x25 drywall screws.

The OAC grille is mounted to FSD with screws M4x10 (DIN 965 TX) as shown in the picture.

The GG1 and GG2 grille is mounted to FSD with screws ISO 7380-2 TX20 M4x10.

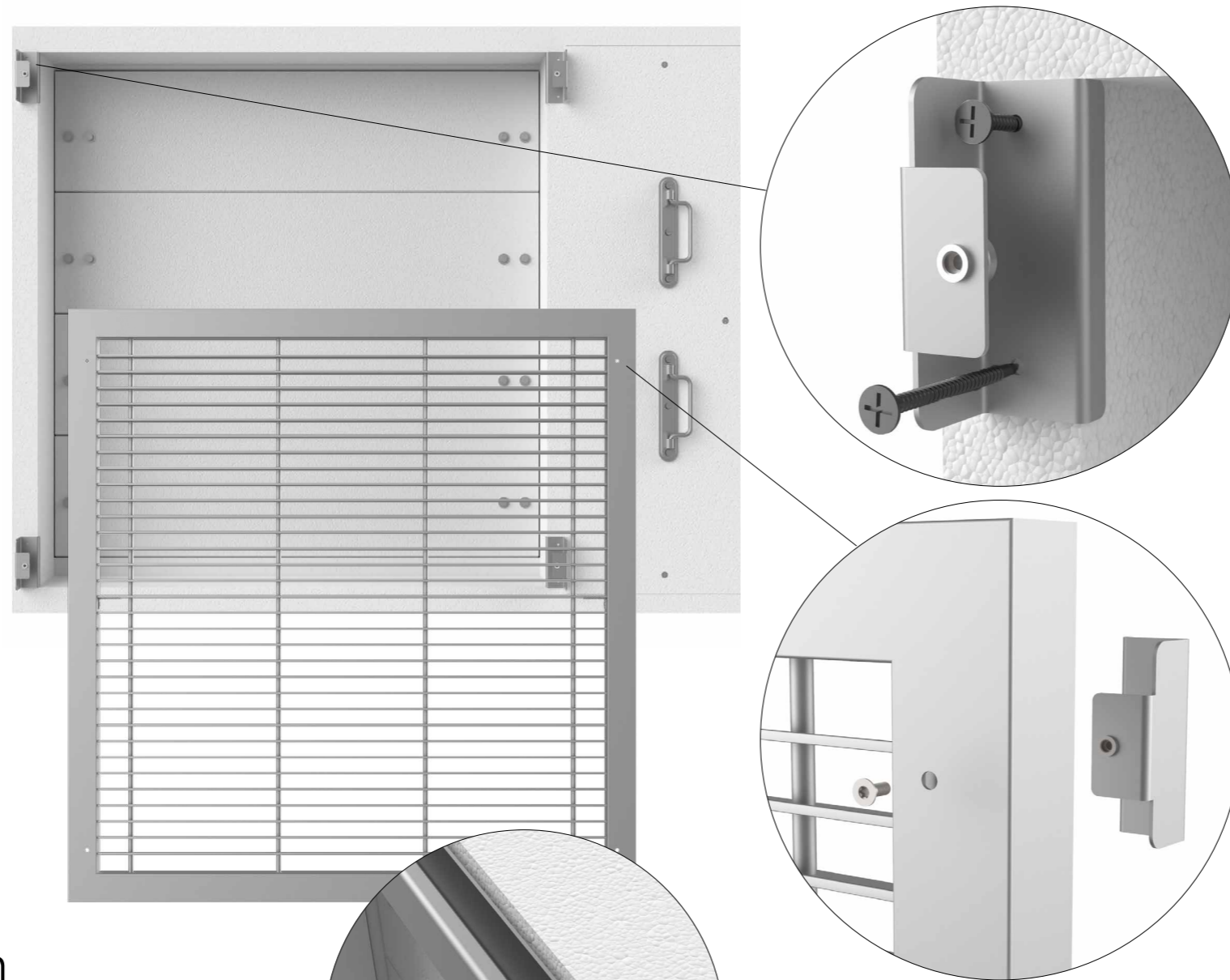

Steel duct connection frame installation

1. Fix the parts of the connection frame to the FSD smoke damper with supplied Ø 4 x 15 mm drywall screws. Put silicone between smoke damper and connection frame.

2. Seal the corners with silicone caulking.

3. Connect the PG30 frame with the duct and seal the connection.

(standard duct connection screws and clips)

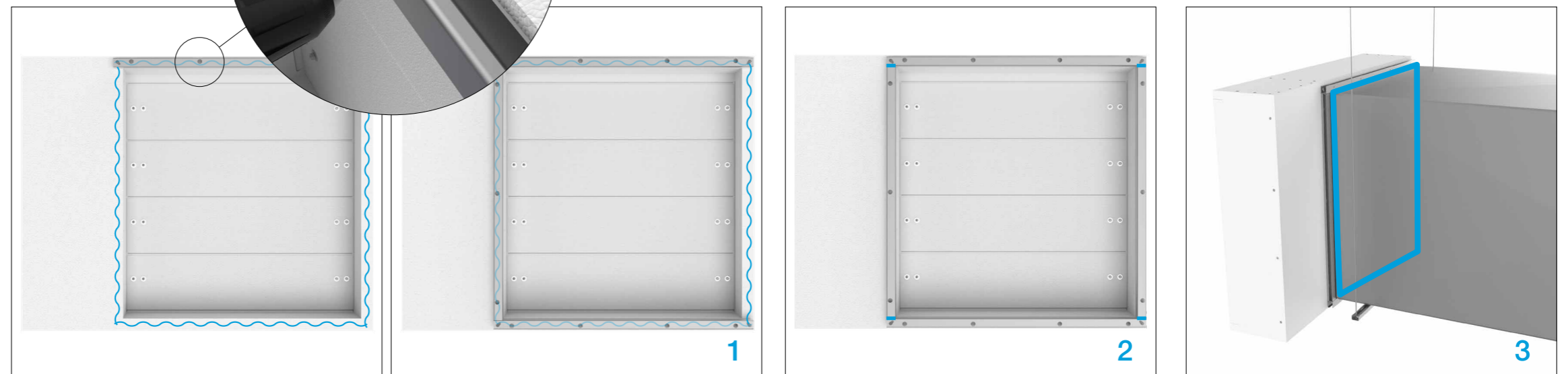

FSD SMOKE CONTROL DAMPER

- ▼ [PRODUCT OVERVIEW](#)
- ▼ [DIMENSIONS](#)
- ▼ [INSTALLATIONS](#)
- ▼ [ACTUATORS](#)
- ▼ [ACCESSORIES](#)
- ▼ [MAINTENANCE AND OPERATION](#)

Suspension bracket for horizontal installation

L profiles for horizontal duct installation picture.



Number of brackets

HxB	200	250	300	350	400	450	500	550	600	650	700	750	800	850	900	950	1000	1050	1100	1150	1200	
240	4	4	4	4	4	4	4	4	4	4	4	4	4	4	4	4	4	4	4	4	4	4
440	4	4	4	4	4	4	4	4	4	4	4	4	4	4	4	4	4	4	4	4	4	4
640	4	4	4	4	4	4	4	4	4	4	4	4	4	4	4	4	4	4	6	6	6	6
840	4	4	4	4	4	4	4	4	4	4	4	6	6	6	6	6	6	6	6	6	6	6
1040	4	4	4	4	4	4	4	6	6	6	6	6	6	6	6	6	6	6	6	6	6	6
1240	4	4	4	6	6	6	6	6	6	6	6	6	6	6	6	6	8	8	8	8	8	8
1440	4	6	6	6	6	6	6	6	6	6	6	8	8	8	8	8	8	8	8	8	8	8
1640	6	6	6	6	6	6	6	6	8	8	8	8	8	8	8	8	8	8	10	10	10	10
1840	6	6	6	6	6	8	8	8	8	8	8	8	8	8	8	10	10	10	10	10	10	10
2040	6	6	8	8	8	8	8	8	8	8	8	10	10	10	10	10	10	10	10	10	10	12

FSD SMOKE CONTROL DAMPER

- ▼ [PRODUCT OVERVIEW](#)
- ▼ [DIMENSIONS](#)
- ▼ [INSTALLATIONS](#)
- ▼ [ACTUATORS](#)
- ▼ [ACCESSORIES](#)
- ▼ [MAINTENANCE AND OPERATION](#)

Communication plate and cable holder Recomended installation position

1. Install the communication module support with 2 with 3,9x30 drywall screws
2. Fix the communication module to the module support with DIN7981 screws.
3. Install the cable support with 2 with 3,9x30 drywall screws.

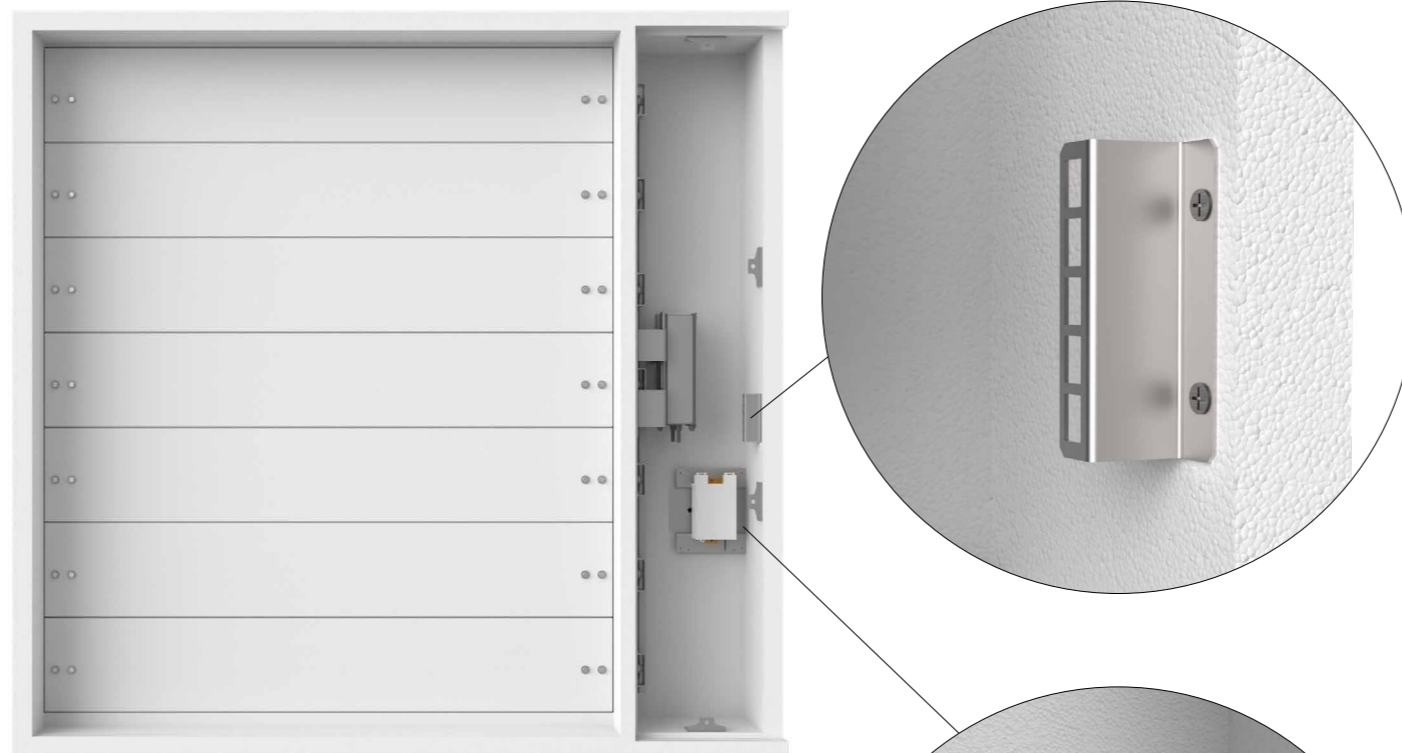

Smaller dimension Cable holder installation position *option 1

1. Install the communication module support with 2 with 3,5x30 drywall screws.
2. Fix the communication module to the module support with DIN7981 drywall screws.
3. Install the cable support with 2 with 3,5x30 drywall screws.

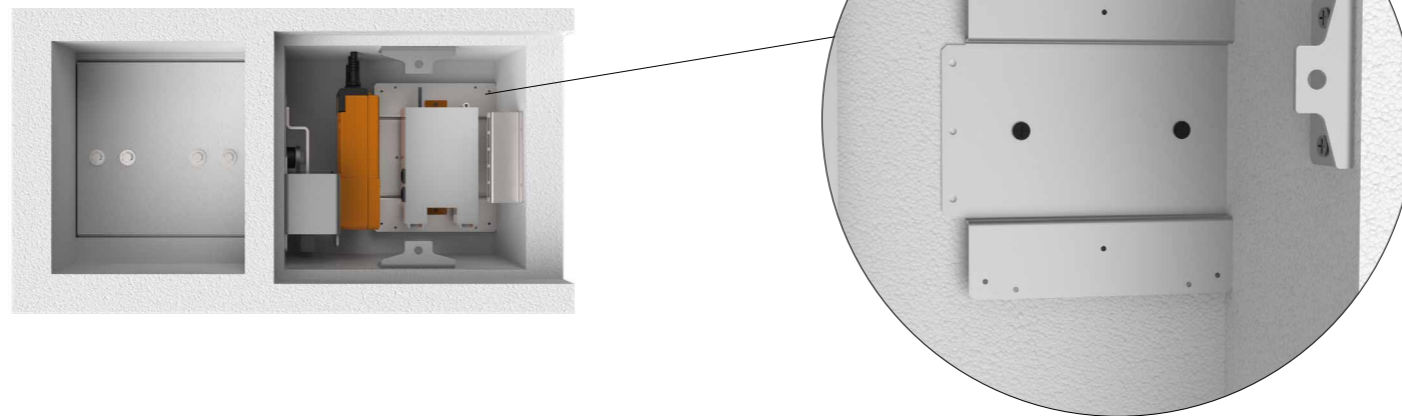

Smaller dimension Cable holder installation position *option 2

1. Install the cable support.
2. Connect the communication module and the module support with DIN7981 screws.
3. Install the assembly on the side of the casing with drywall screws 3.9x30.

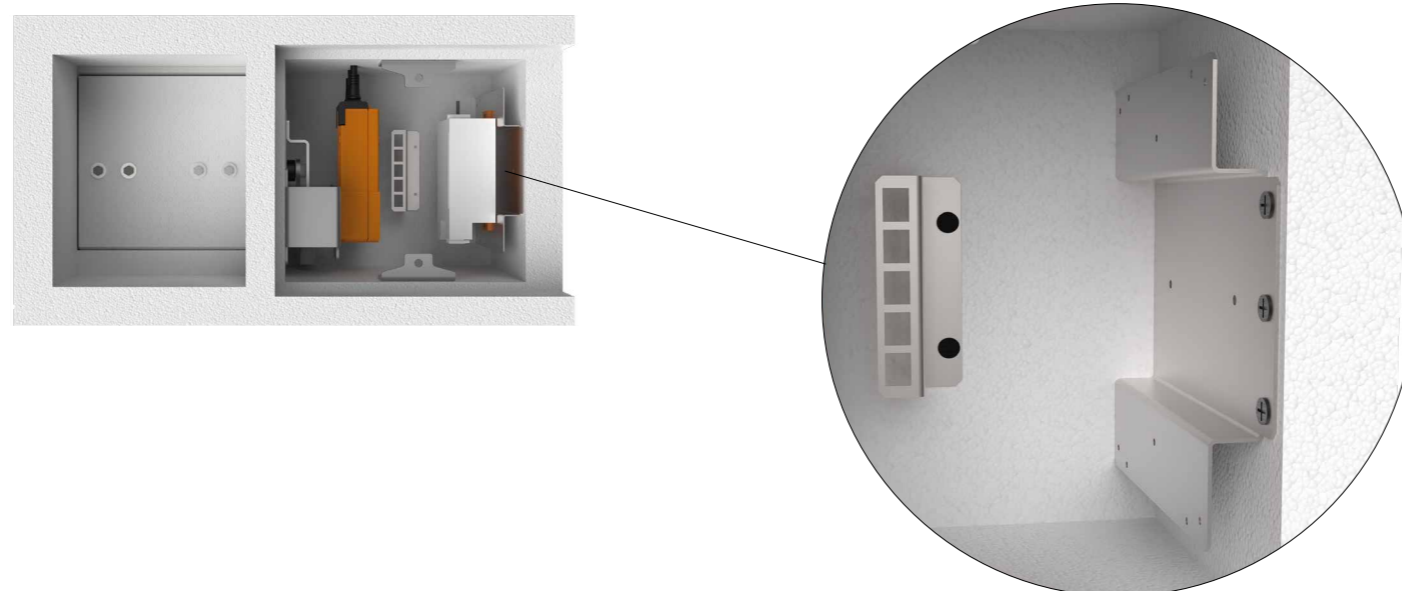

FSD SMOKE CONTROL DAMPER

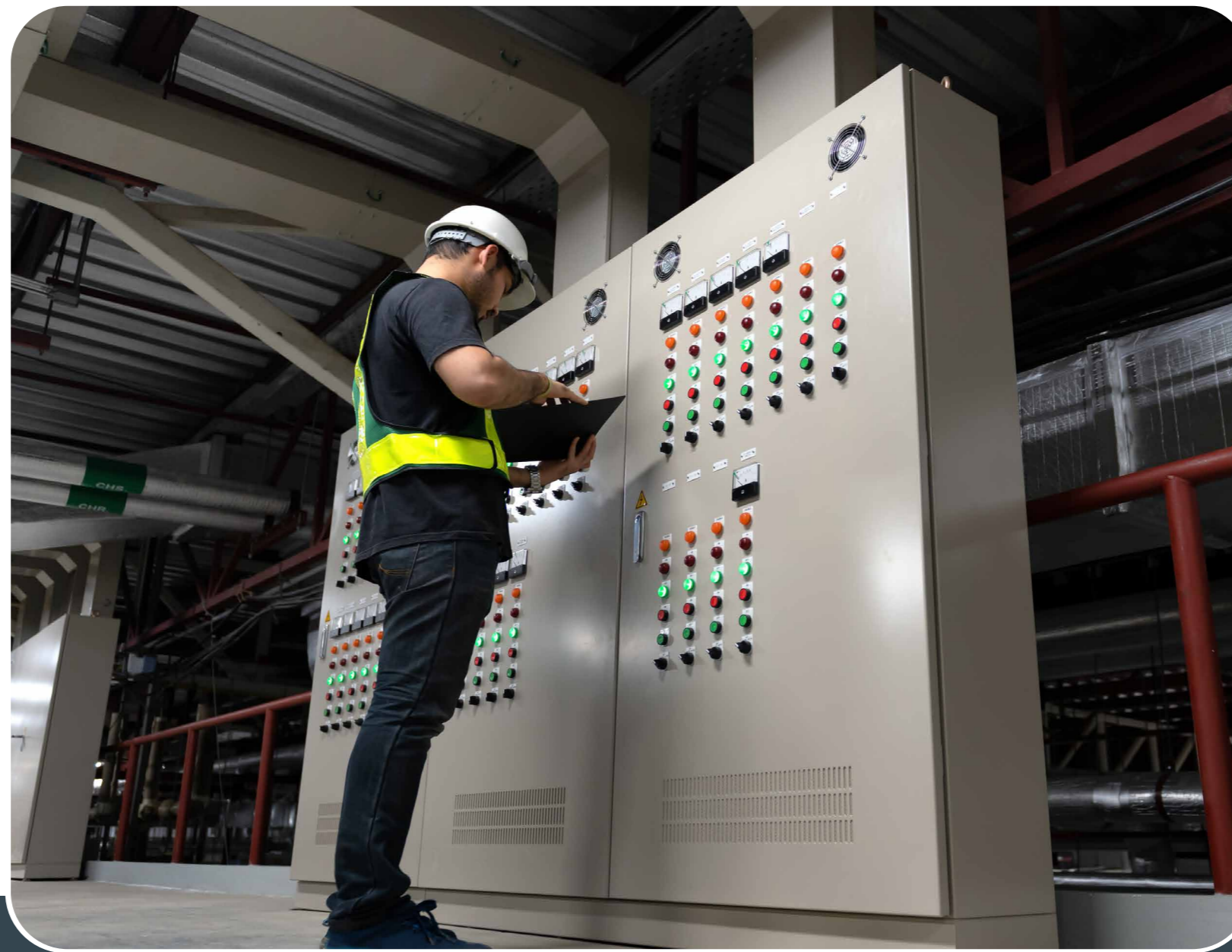

- ▼ [PRODUCT OVERVIEW](#)
- ▼ [DIMENSIONS](#)
- ▼ [INSTALLATIONS](#)
- ▼ [ACTUATORS](#)
- ▼ [ACCESSORIES](#)
- ▼ [MAINTENANCE AND OPERATION](#)



MAINTENANCE

FSD SMOKE CONTROL DAMPER

TRANSPORT

After arrival, check the smoke control damper for transport damage and shortcomings. In case of any damage or shortcomings, immediately contact your supplier.

STORAGE

If the damper is not installed immediately

- Remove any wrapping.
- Protect damper from dust and contamination.
- Do not expose the product to the effects of weather - store smoke control damper in dry place.
- Do not store the unit below -20 °C or above 50 °C.

Please properly dispose of packaging material!

WARNING!

Danger of electric shock! Do not touch any live components! Electrical equipment carries a dangerous electrical voltage. Switch off the power supply before working on any electrical equipment!

MAINTENANCE AND CLEANING

FSD is maintenance free. Our smoke control dampers can be wiped (dust, ...) with a wet or dry cloth and additionally vacuumed with an industrial vacuum cleaner, except for electronic parts. To avoid damage to the blades and bearings, use soft cloths.

Never use chlorine-based corrosive agents!

COMMISSIONING

Carefully unpack FSD smoke control damper - be careful of sharp edges and do not use excessive force for unpacking. Wear protective gloves, safety shoes and a hard hat.

- Inspect the product - check the smoke damper for damage
- Installation of the smoke control damper - according to the installation instructions ([page 8.](#)).

FUNCTIONS

Functional reliability must be controlled or tested every six months. If two consecutive tests are successful, the next functional test can be performed in one year.

Functionality testing must be carried out in accordance with the following norms:

- EN 12101-8
- EN 13306
- EN 15423
- According to the norms represented in the country of installation

Never use the smoke control damper:

- in areas with potentially explosive atmospheres
- outdoors without sufficient protection against the effects of weather and outside of temperature limits
- in atmospheres where chemical reactions, whether planned or unplanned, may cause damage to the smoke control damper or lead to corrosion



FIRE DAMPER - FD

 Joseph Wilson Industrial Estate, Whitstable, CT5
 3DU UK+44 (0) 1634
 actionair@swegon.com
 www.swegon.com/uk/
