

Product manual

ThermCommand FDSD EIS Classified Smoke Control Damper

Fire protection

Version 3.0
Issue Date: 28.10.2025.

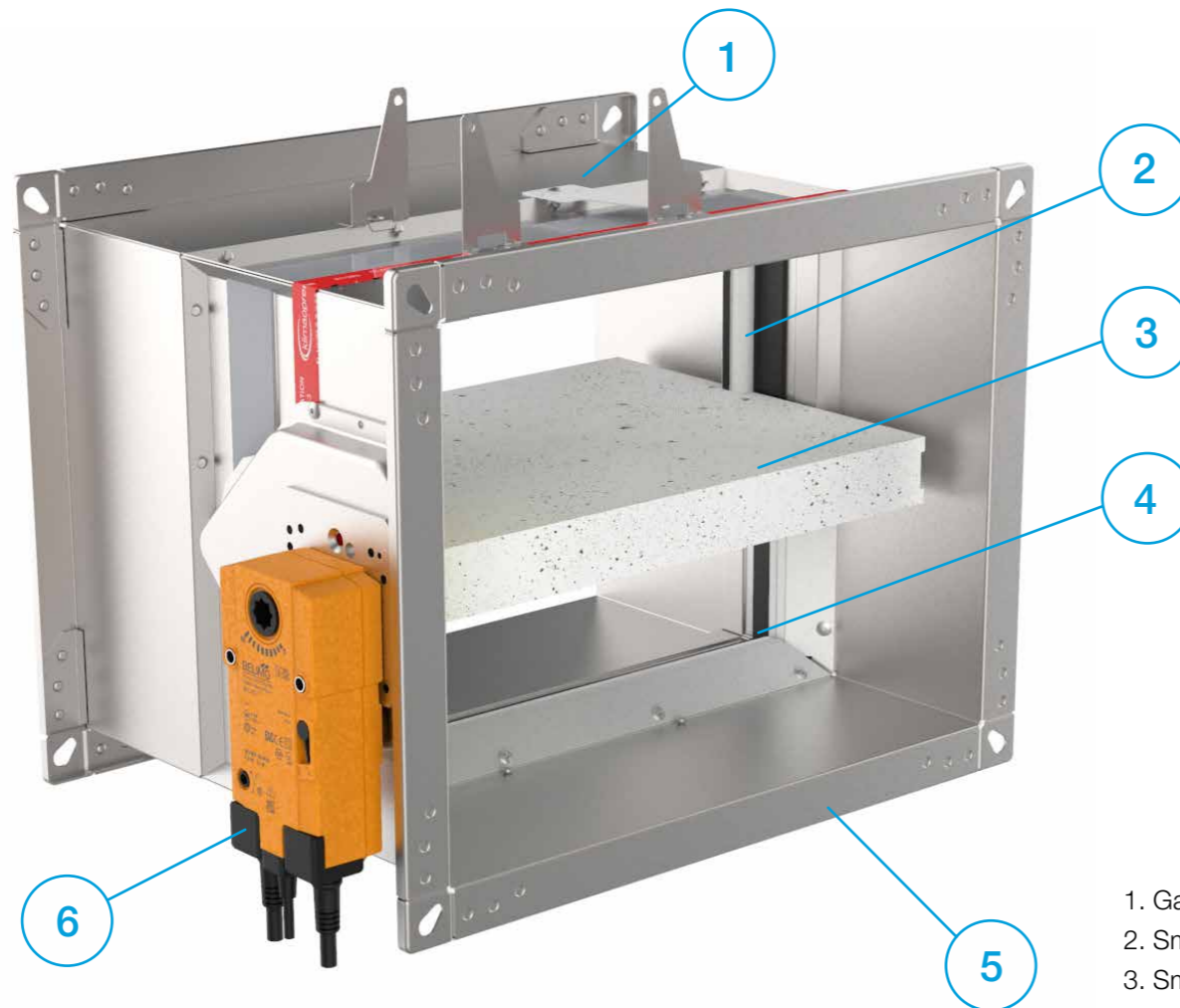

1. Galvanized steel sheet casing
2. Smoke seal
3. Smoke resistant damper blade
4. Intumescent joint
5. Connection flanges
6. Actuator

- ▼ [PRODUCT OVERVIEW](#)
- ▼ [DIMENSIONS](#)
- ▼ [INSTALLATIONS](#)
- ▼ [ACTUATORS](#)
- ▼ [REPLACEMENTS](#)
- ▼ [MAINTENANCE AND OPERATION](#)

SMOKE CONTROL DAMPERS

PRODUCT OVERVIEW

Smoke control dampers FDSO are used in smoke extraction systems for extraction of smoke gases or providing supply air to one or more fire compartments. Smoke control dampers consist of steel sheet case, calcium silicate damper blade, damper blade mechanism outside of the airflow and an electric actuator.

Smoke control damper case is made out of galvanized steel sheet casing. Calcium silicate blade is equipped with brass bearings and seals made out of silicone and graphite gasket. Smoke control dampers FDSO are produced in sizes from 200x200 till 1200x800 mm.

FDSO dampers are equipped with Belimo actuator drives in 24 V or 230 V versions.

Activation of smoke control dampers equipped with electric drives can be via smoke detector or remotely via control

signal. Rearming of the electric smoke damper can also be done remotely via control signal. All electric actuators are equipped with end switches for position signalling.

In the case of fire, there are two possible safe positions for the smoke control damper, open or closed, depending on the situation on site and smoke extraction scenario.

Smoke control dampers are designed for installation in standard rigid supporting construction at least 100 mm thick, with bulk density of at least 450 kg/m³, in flexible walls with plasterboard panels type F (EN520), with wall filling with mineral wool with a density of up to 115 kg/m³ (wall thickness at least 100 mm), and for installation in ducts that have been tested to EN1366-9 and EN1366-8.

All smoke control dampers are tested according to the EN 1751 for airtightness, class C on the casing air leakage.



- ▼ [PRODUCT OVERVIEW](#)
- ▼ [DIMENSIONS](#)
- ▼ [INSTALLATIONS](#)
- ▼ [ACTUATORS](#)
- ▼ [REPLACEMENTS](#)
- ▼ [MAINTENANCE AND OPERATION](#)



FIRE RESISTANCE CLASSIFICATION

FDSD smoke control damper is tested according to EN 1366-10 "Fire resistance tests for service installations - Smoke control dampers". Classification of the FDSD smoke control dampers is defined according to EN 13501-4 "Fire classification of construction products and building elements using data from fire resistance tests". Classification of FDSD smoke control damper is: **EI 60/90/120 (vedw i↔o) S1000/1500 Cmod AA multi**. Smoke damper should be installed according installation manual which can be found within this document.

Please consult latest Declaration of Performance on our website:

For more information about certificates, visit our website:

E - Integrity
I - Insulation
60/90/120 - Classification time in minutes
ve - Damper installed in vertical position
ho - Damper installed in horizontal position
i↔o - Fire performance criteria are met on both sides
S - Smoke leakage
Cmod - 20 000 Cycles
AA - automatic intervention
MULTI- usage in compartments classified as "multi", can be used aslo in compartments classified as "single"



TECHNICAL DATA

Smoke control damper casing is manufactured from the galvanized steel sheet and damper blade is made of calcium silicate.



<p>1</p> <p>4</p> <p>5</p> <p>6</p> <p>7</p> <p>8</p> <p>15</p> <p>16</p>	<p>SERIAL NUMBER 29560500100001</p> <p>PRODUCTION DATE 10.05.2024</p> <p>TYPE: FDSD – 500X300 – M230</p> <p>DIMENSION: 500x300x350</p> <p>ACT. MECHANISM: M230</p> <p>NOMINAL VOLTAGE: AC 230</p> <p>SIGNALISATION Yes</p>	<p>2</p> <p>3</p> <p>9</p> <p>10</p> <p>11</p> <p>12</p> <p>13</p> <p>14</p>
---	--	--



21
1396-CPR-0198

EN 12101 – 8:2011

CLASS C EN1751

Multicompartment

Smoke control damper
DoP No. 1716/07-2023

EI/60/90/120 (Vedw i ↔ o) S1000/1500 Cmod AA multi

PRODUCT MUST BE INSTALLED BY INSTRUCTIONS SUPPLIED BY MANUFACTURER

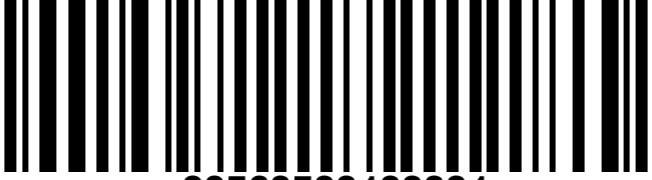

29560500100001

- ▼ [PRODUCT OVERVIEW](#)
- ▼ [DIMENSIONS](#)
- ▼ [INSTALLATIONS](#)
- ▼ [ACTUATORS](#)
- ▼ [REPLACEMENTS](#)
- ▼ [MAINTENANCE AND OPERATION](#)



PRODUCT OVERVIEW

SMOKE CONTROL DAMPERS

Rating plate

- 1 - Company logo
- 2 - Serial number
- 3 - Production date
- 4 - Type
- 5 - Dimension of the smoke control damper
- 6 - Mechanism type
- 7 - Nominal voltage
- 8 - Signalisation (end contacts)
- 9 - IP protection
- 10 - Free space
- 11 - Number of the European standard and year of its publication
- 12 - Classification according to EN 1751
- 13 - Classification according to EN 13501-4
- 14 - Barcode
- 15 - CE conformity marking symbol
- 16 - Identification number of the notified product certification body

Product specifications

Nominal sizes FDSD	200x200 - 1200x800 [mm]
Casing length	350 mm
Temperature range	-20 °C ... 50 °C
Volume flow rate range	up to 20.700 m ³ /h
Differential pressure ranges	up to 2.000 Pa
Casing air leakage	Class C, EN 1751
Upstream velocity	< 12 m/s
EC conformity	EN13501-4, EN1366-10, EN12101-8, EN1751, CPR no.3/2011
Declaration of performance	DoP No. 1716/2020_EN

Ordering key

(1) Damper type (2) Dimension (3) Mechanism type

FDSD - 400x300 - M230-S

(1) **FDSD**

(2) Damper dimensions
B(W) x H [mm]

(3) **M24-S**
M230-S
M24-S-ST
M24-SR

- electric actuator AC/DC 24 V
- electric actuator AC/DC 230 V
- electric actuator AC/DC 24 V (with plug)
- electric actuator AC/DC 24 V (modulating)

FDSD

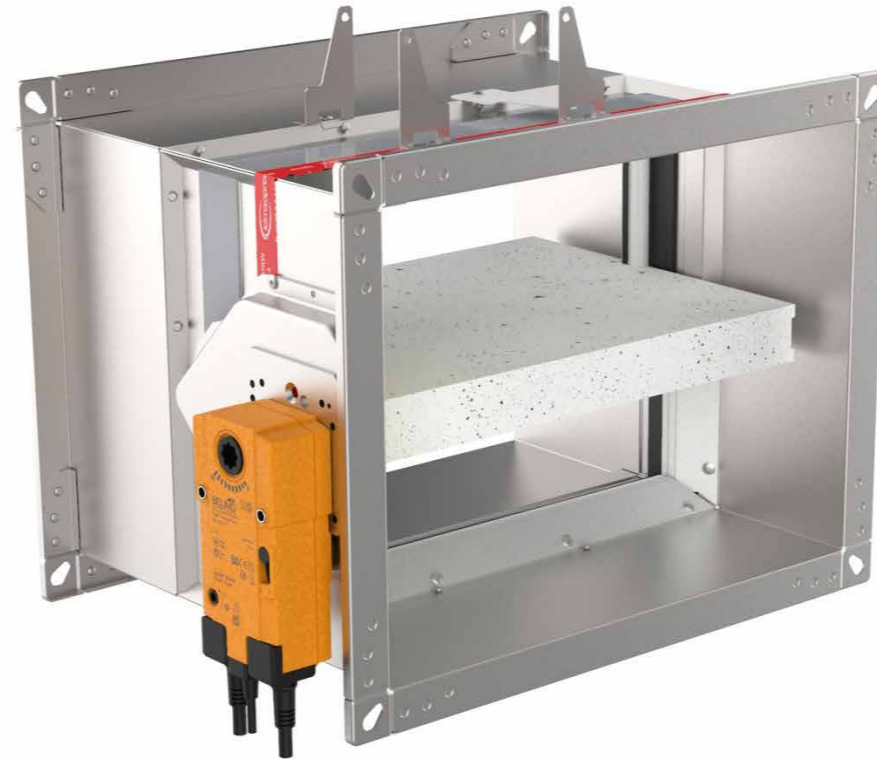

- ▼ [PRODUCT OVERVIEW](#)
- ▼ [DIMENSIONS](#)
- ▼ [INSTALLATIONS](#)
- ▼ [ACTUATORS](#)
- ▼ [REPLACEMENTS](#)
- ▼ [MAINTENANCE AND OPERATION](#)

↑ DIMENSIONS

SMOKE CONTROL DAMPERS

Actuator	A [mm]	C [mm]	D [mm]	E [mm]
BEN (M)	25	200	90	120
BEE (M)	25	225	100	120

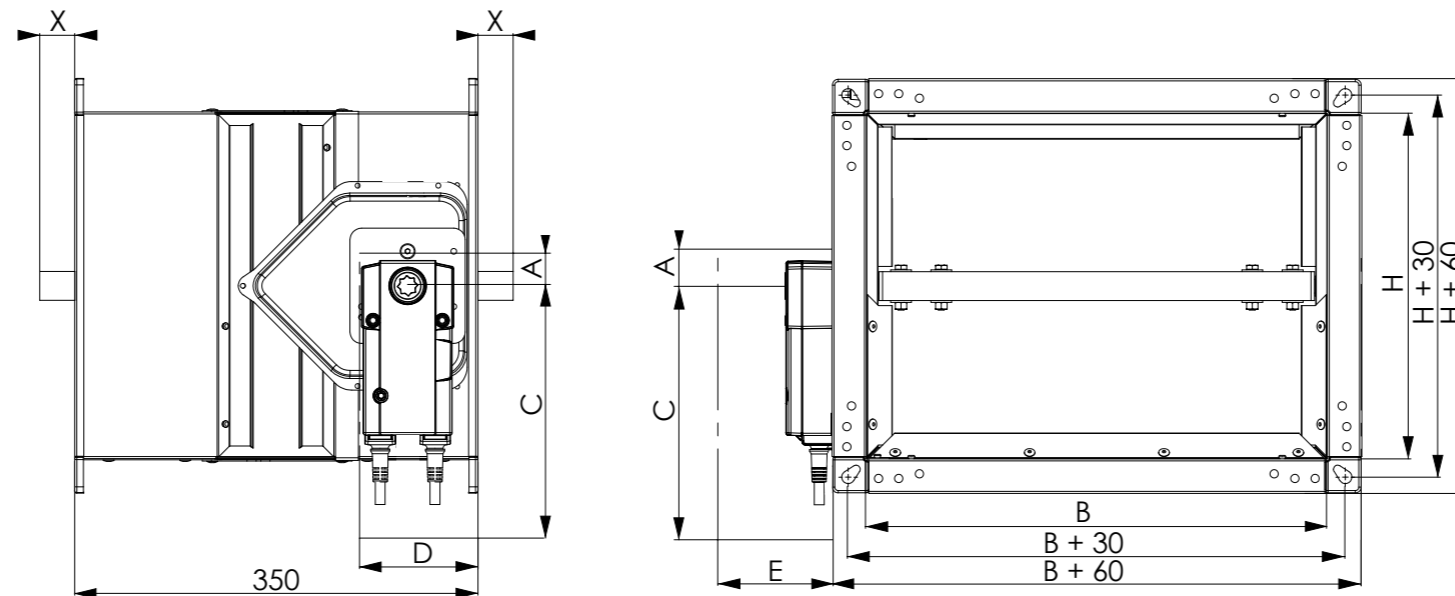







Length of damper blade outside of casing:

$$X = (H/2) - 175 \text{ [mm]}$$

		FDSD Weight [kg]																			
H/B	200	250	300	350	400	450	500	550	600	650	700	750	800	850	900	950	1000	1050	1100	1150	1200
200	6,8	7,5	8,2	8,9	9,7	10,4	11,1	11,8	12,6	14,0	14,7	15,5	16,2	16,2	16,9	17,6	18,3	19,1	19,8	20,5	21,3
250	7,5	8,3	9,1	9,9	10,7	11,6	12,4	13,2	14,0	15,6	16,5	17,3	18,1	18,2	19,0	19,8	20,7	21,5	22,3	23,2	24,0
300	8,2	9,1	10,0	10,9	11,8	12,7	13,6	14,5	15,4	17,3	18,2	19,1	20,0	20,2	21,1	22,1	23,0	23,9	24,9	25,8	27,5
350	8,9	9,9	10,9	11,9	12,9	13,9	14,9	15,9	16,9	18,9	19,9	20,9	22,0	22,2	23,3	24,3	25,3	26,4	27,4	28,4	30,2
400	9,7	10,7	11,8	12,9	14,0	15,1	16,2	17,3	18,3	20,5	21,6	22,8	23,9	25,0	26,2	27,3	28,4	29,5	30,7	31,8	32,9
450	10,4	11,6	12,7	13,9	15,1	16,3	17,4	18,6	19,8	22,1	23,4	24,6	25,8	27,1	28,3	29,5	30,7	32,0	33,2	34,4	35,7
500	11,1	12,4	13,6	14,9	16,2	17,4	18,7	20,0	21,2	23,8	25,1	26,4	27,8	29,1	30,4	31,7	33,1	34,4	35,7	37,1	38,4
550	11,8	13,2	14,5	15,9	17,3	18,6	20,0	21,3	22,7	25,4	26,8	28,3	29,7	31,1	32,5	34,0	35,4	36,8	38,3	39,7	41,1
600	12,6	14,0	15,4	16,9	18,3	19,8	21,2	22,7	24,1	27,0	28,6	30,1	31,6	33,1	34,7	36,2	37,7	39,3	40,8	42,3	43,8
650		15,6	17,3	18,9	20,5	22,1	23,8	25,4	27,0	28,7	30,3	31,9	33,5	35,2	36,8	38,4	40,1	41,7	43,3	45,1	46,7
700			18,2	19,9	21,6	23,4	25,1	26,8	28,6	30,3	32,0	33,7	35,5	37,2	38,9	40,7	42,4	44,2	46,0	47,7	49,4
750				20,9	22,8	24,6	26,4	28,3	30,1	31,9	33,7	35,6	37,4	39,2	41,1	42,9	44,8	46,7	48,5	50,3	52,1
800					23,9	25,8	27,8	29,7	31,6	33,5	35,5	37,4	39,3	41,3	43,2	45,2	47,2	49,1	51,0	52,9	54,9

 BEN-24/230

 BEE-24/230

-  [PRODUCT OVERVIEW](#)
-  [DIMENSIONS](#)
-  [INSTALLATIONS](#)
-  [ACTUATORS](#)
-  [REPLACEMENTS](#)
-  [MAINTENANCE AND OPERATION](#)

Pressure drop tables

Pressure drop values are described with the “Zeta” values for each size. The exact pressure drop in [Pa] is calculated using the following formula:

$$\Delta p \text{ [Pa]} = \zeta * v^2 * 0,6$$

Where ζ is Zeta value from the tables below, v is airflow velocity in [m/s].

		ZETA VALUES FDSD																			
H/B	200	250	300	350	400	450	500	550	600	650	700	750	800	850	900	950	1000	1050	1100	1150	1200
200	11,64	9,56	7,48	6,91	6,33	5,71	5,09	5,06	5,04	4,75	4,46	4,45	4,44	4,42	4,39	4,11	3,84	3,83	3,81	3,80	3,79
250	8,58	7,11	5,65	5,20	4,76	4,29	3,82	3,80	3,78	3,56	3,33	3,32	3,31	3,29	3,27	3,07	2,86	2,85	2,84	2,83	2,83
300	5,51	4,67	3,83	3,50	3,18	2,86	2,55	2,54	2,53	2,36	2,20	2,19	2,18	2,17	2,15	2,02	1,89	1,88	1,86	1,86	1,86
350	4,47	3,78	3,10	2,84	2,58	2,32	2,07	2,05	2,03	1,91	1,78	1,77	1,76	1,75	1,75	1,64	1,53	1,52	1,52	1,51	1,51
400	3,42	2,89	2,37	2,17	1,98	1,78	1,59	1,56	1,53	1,45	1,36	1,35	1,34	1,34	1,34	1,26	1,17	1,17	1,17	1,16	1,15
450	2,91	2,47	2,02	1,85	1,67	1,50	1,33	1,31	1,30	1,23	1,15	1,15	1,14	1,14	1,14	1,07	1,00	1,00	1,00	0,99	0,97
500	2,40	2,04	1,68	1,52	1,36	1,21	1,07	1,07	1,07	1,00	0,94	0,94	0,94	0,94	0,94	0,88	0,82	0,82	0,82	0,81	0,80
550	2,13	1,81	1,48	1,35	1,22	1,09	0,97	0,95	0,93	0,88	0,82	0,82	0,82	0,82	0,82	0,76	0,71	0,71	0,71	0,70	0,70
600	1,86	1,57	1,28	1,18	1,08	0,97	0,87	0,84	0,80	0,76	0,71	0,70	0,69	0,69	0,69	0,64	0,59	0,59	0,59	0,59	0,59
650		1,10	1,10	1,02	0,93	0,85	0,77	0,74	0,70	0,66	0,62	0,62	0,61	0,61	0,61	0,57	0,53	0,53	0,53	0,53	0,53
700			0,93	0,85	0,78	0,72	0,67	0,63	0,60	0,57	0,53	0,53	0,53	0,53	0,53	0,50	0,47	0,47	0,47	0,47	0,47
750				0,75	0,71	0,65	0,60	0,58	0,56	0,53	0,50	0,49	0,47	0,47	0,47	0,44	0,42	0,42	0,42	0,42	0,42
800					0,63	0,58	0,54	0,53	0,52	0,49	0,46	0,44	0,41	0,41	0,41	0,39	0,36	0,36	0,36	0,36	0,36



SMOKE CONTROL DAMPERS

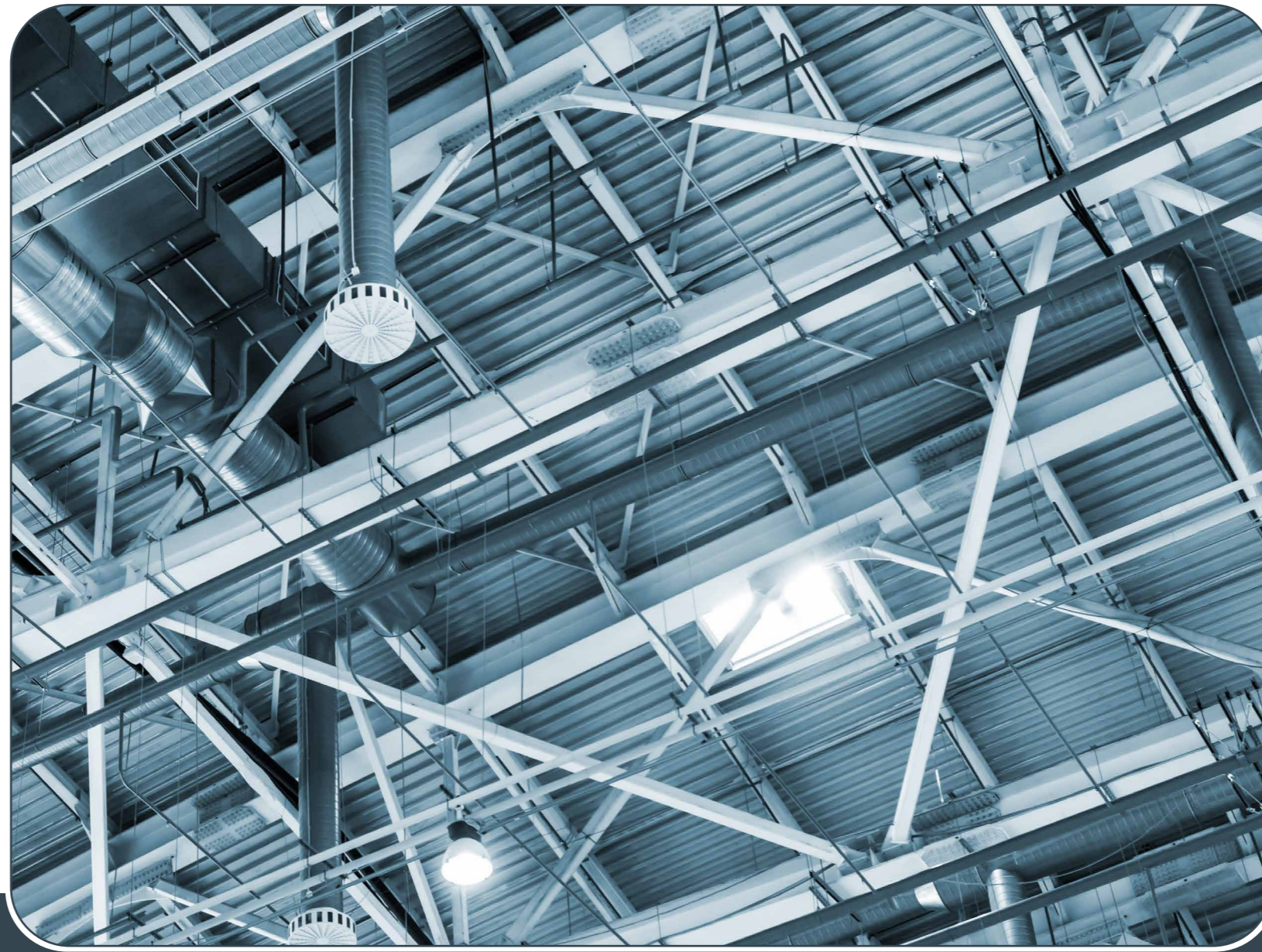

- ▼ [PRODUCT OVERVIEW](#)
- ▼ [DIMENSIONS](#)
- ▼ [INSTALLATIONS](#)
- ▼ [ACTUATORS](#)
- ▼ [REPLACEMENTS](#)
- ▼ [MAINTENANCE AND OPERATION](#)

SMOKE CONTROL DAMPERS

INSTALLATION

The FDS smoke control damper has been tested according to EN1366-10 in solid walls, flexible plasterboard walls and ducts tested according to EN1366-8.

The duct connected to the smoke control damper must be supported or hung in such a way that the damper does not carry its weight. The damper must not support any part of the surrounding construction or wall which could cause damage and consequent damper failure. The damper driving mechanism can be placed on either side of the wall, however it needs to be placed so as to ensure easy access during inspection.

The smoke control damper must be installed into a fire partition structure in such a way that the damper blade in its closed position is located inside this structure.

- The installation must comply with the tests that were performed during certification
- Avoid any obstruction of the moving blade by the connected ducts
- The class of air-tightness is maintained in case the installation of the damper is made in accordance with the technical manual
- For indoor use only
- If the damper is installed in a wall of a lower fire resistance class, the damper itself will have a lower fire resistance class
- Multi compartment smoke control dampers tested on the surface of the duct may also be used in line with single or multi compartment smoke control duct (i.e. between duct sections), providing that the smoke control damper is independently provided with a duct support (support, drop rod, anchor etc. - as tested for the smoke control duct) with 100 mm of the center of the smoke control damper blade axis. The damper should not support the duct or vice versa.

All dampers have to be installed with the blade axis in a horizontal position. To help you find the suspension plane, a bendable fixing bracket is provided on the damper casing and the red tape is placed on the casing to mark the location of the wall limit

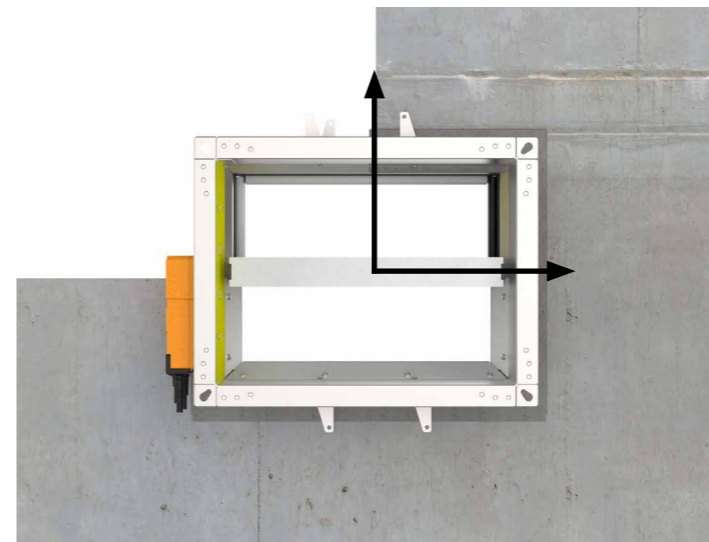

Check the operation of the smoke control damper before commencing the installation!

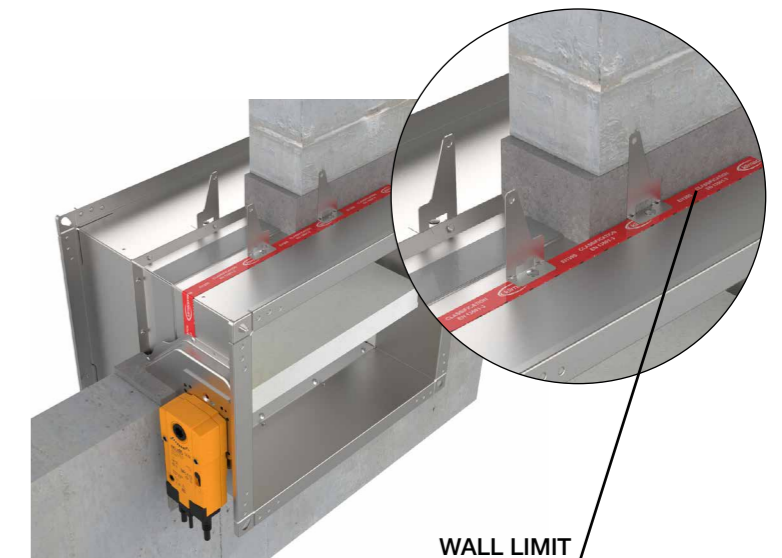

WALL LIMIT

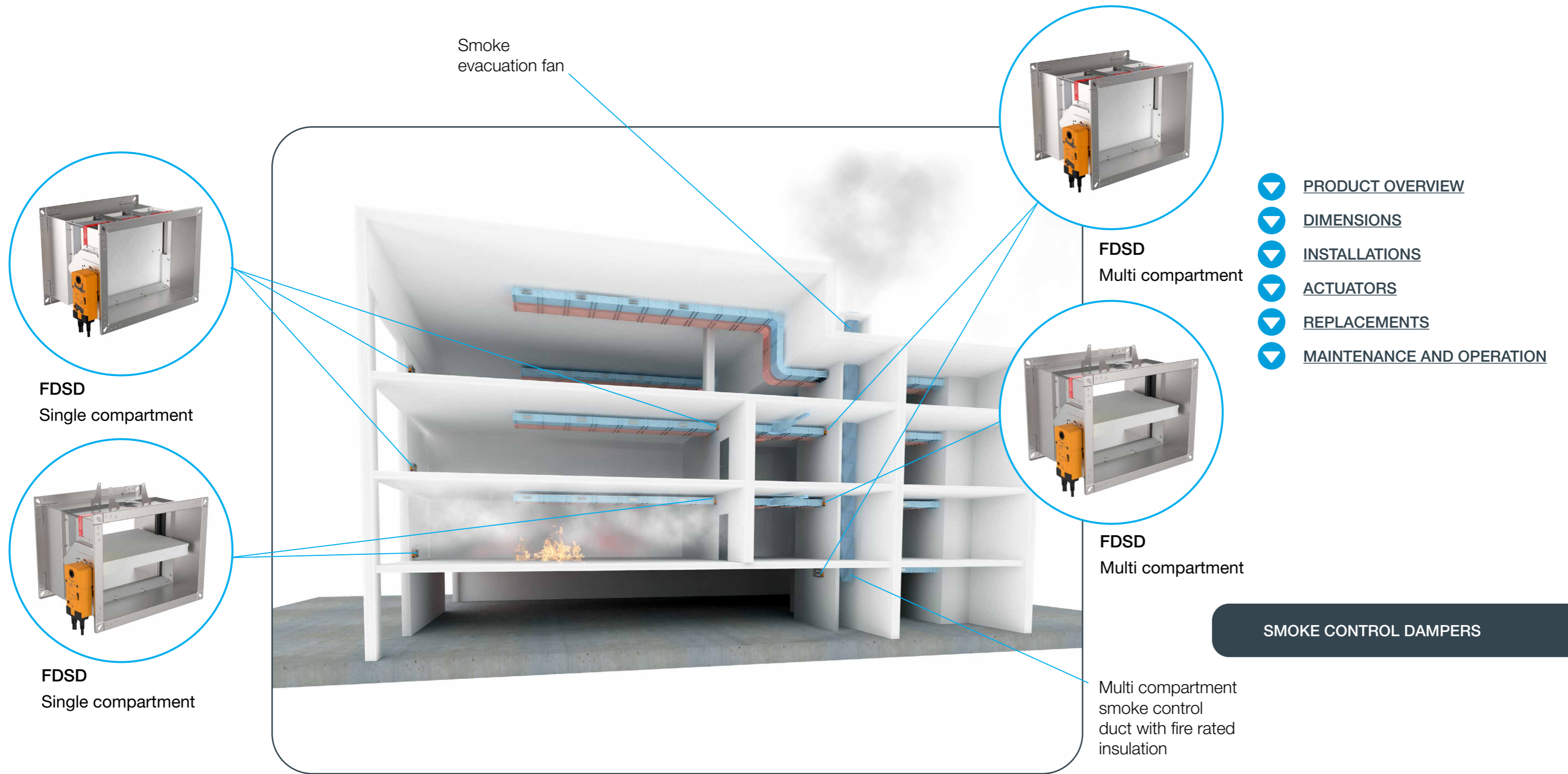

SMOKE CONTROL DAMPERS

Multi-compartment smoke control dampers may be used with alternative duct systems meeting EN 1366-9 and EN 1366-8, provided they are made of the same material as tested, meet or exceed the tested material density and thickness, maintain consistent materials for surface protection and adhere to tested paint finishes.

Multi compartment smoke control dampers











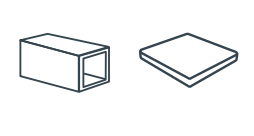

EN 12101-8: Smoke control dampers, which are fire resisting, for use in multi compartment areas, which may be associated with multi or single compartment smoke control ductwork and/or may be installed in a fire compartment structure.

Single compartment smoke control dampers

EN 12101-9: Smoke control dampers for use in single compartment areas, which may be associated with single compartment smoke control ductwork and/or may be installed in an external wall or roof.

INSTALLATION

Check for more information about certificate installations in the declaration of performance:

Range	Installation	Supporting construction	Type of installation	Wall thickness	Supporting construction details	Classification	Max. underpressure	Max. overpressure	Details
FDSD	Installation in wall	Rigid wall	Gypsum plaster	≥ 100 mm	Aerated concrete, Reinforced concrete, Gypsum blocks etc (≥ 450 kg/m ³)	EI 120 (ved i↔o) S1500 Cmod AA multi	1500 Pa	500 Pa	    
				≥ 100mm	Two layers of 12.5 GKF gypsum plasterboards on each side, 50mm mineral wool up to 115 kg/m ³	EI 120 (ved, i↔o) S1000 Cmod AA multi	1000 Pa	500 Pa	  
	Vertical on duct	Duct tested on EN 1366-8 or EN 1366-9, Promat Promatect L500	Installation in duct-own design, boards and glue		EI 90 (ved i↔o) S1500 Cmod AA multi	1500 Pa	500 Pa	  	
				Duct tested on EN 1366-8 or EN 1366-9, FIRESAFE FIRE RATED DUCTWORK, LTD-CF/EN/E120/I120/GS/CT18/R	Installation in prefabricated duct	EI 60 (ved i↔o) S1000 Cmod AA multi E 90 (ved i↔o) S1000 Cmod AA multi	1000 Pa	500 Pa	 

 Aerated concrete (≥ 450 kg/m³) or reinforced concrete (≥ 2200 kg/m³) wall, more than 100 mm thick

 Plasterboard wall, type F (EN520), more than 100 mm thick

 Gypsum plaster sealing

SMOKE CONTROL DAMPERS

 Multi-compartment (one side), gypsum plaster sealing

 Multi-compartment (both side), gypsum plaster sealing

 Duct installation

Support for installation with gypsum plaster

In the smoke control damper installations with gypsum plaster, it is necessary to use wooden supports to prevent the casing from deforming while gypsum plaster is getting hardened. Before filling the gap between wall and smoke control damper, close the damper blade and install the wooden supports as seen in the picture below.

Place the wooden support as close as possible to the smoke control damper blade!



Flexible wall subframe

When installing the smoke control dampers in the flexible walls it is necessary to make a metal subframe onto which the damper will be fixed with screws. Subframe should be prepared according to the drawings below.

FDSD ≤ 500 mm

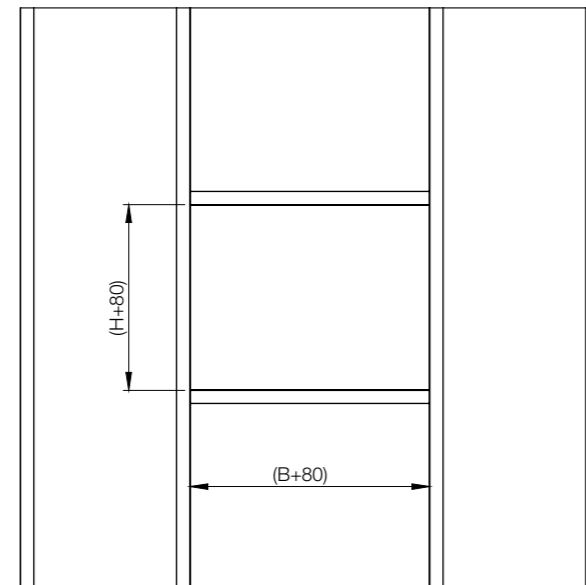

FDSD > 500 mm

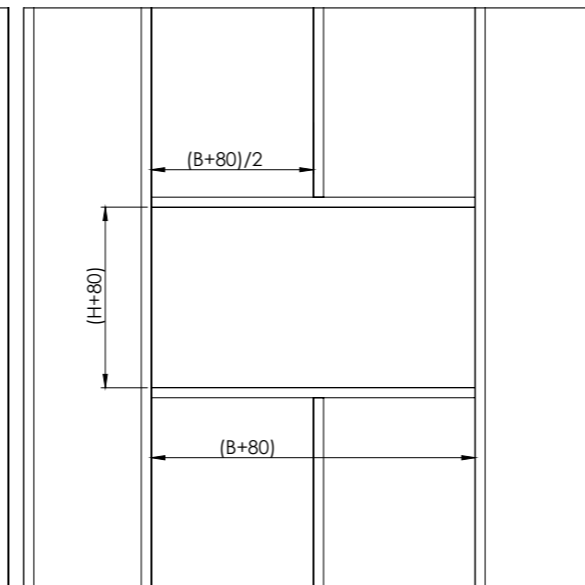

Accessories

Accessories are not intended for connection to a duct!

1 Safety grill - safety grille and extension piece are assembled at the factory to form a unit and exclusively on the operation side of the damper. The free cross sectional area of the cover grille is approx. 70%.

2 Extension piece on operation side - length 350 mm.

3 Communication module bracket



SMOKE CONTROL DAMPERS

Ordering key

(1) Type (2) Accessories (3) Dimension

FD-A - SG1 - 800x600

(1) **FD-A** -accessories for FDSD

(2) **SG1** - Safety grill on operation side
EXT1 - Extension piece on operation side

(3) BxH nominal size of the rectangular damper

Rigid wall installation (gypsum plaster sealing)

Rigid wall (aerated concrete, reinforced concrete, gypsum blocks, etc.) with minimum density of 450 kg/m³ and minimum thickness of 100 mm.
Installation material: gypsum plaster.



INSTALLATION

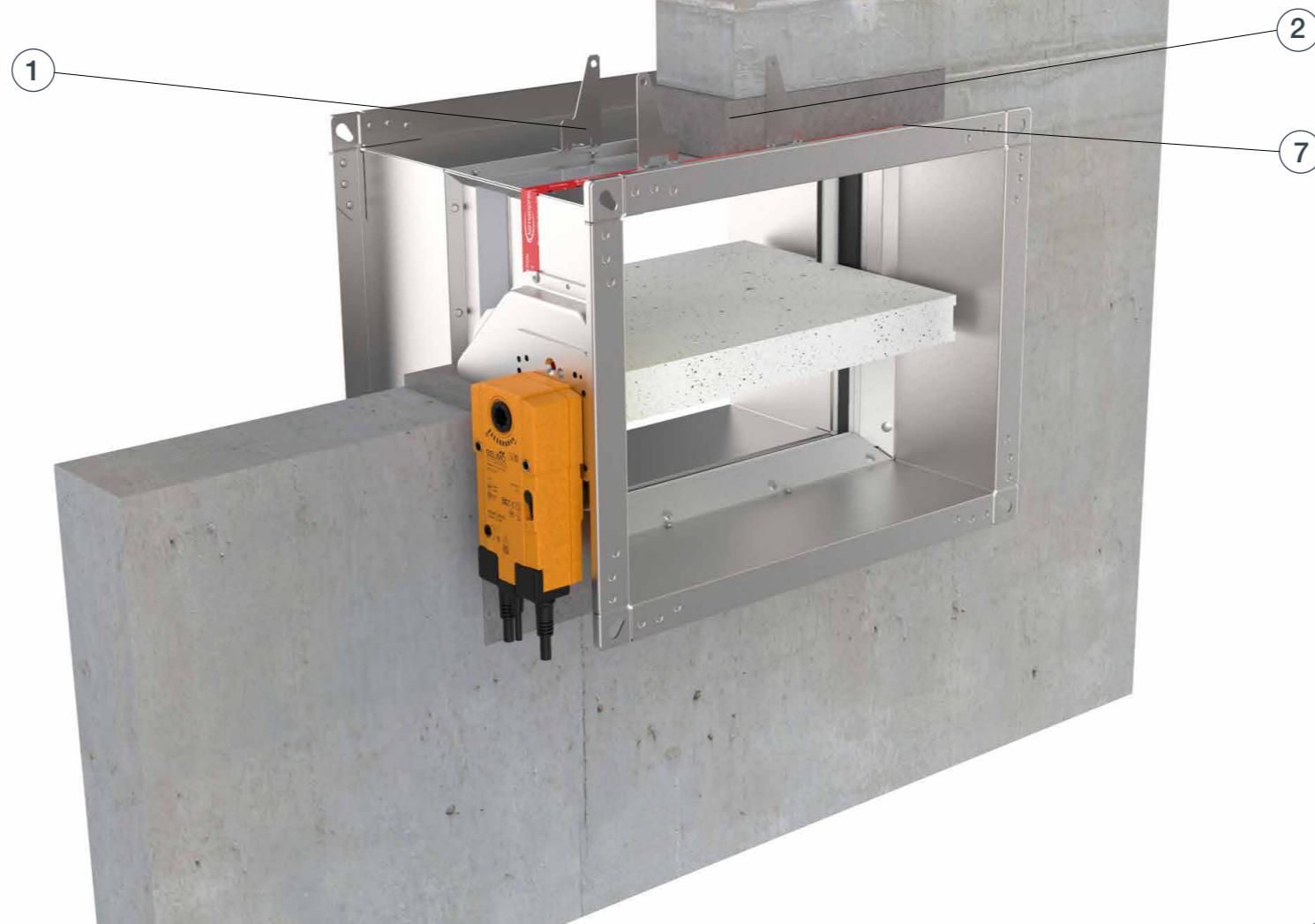

- ▼ [PRODUCT OVERVIEW](#)
- ▼ [DIMENSIONS](#)
- ▼ [INSTALLATIONS](#)
- ▼ [ACTUATORS](#)
- ▼ [REPLACEMENTS](#)
- ▼ [MAINTENANCE AND OPERATION](#)

SMOKE CONTROL DAMPERS

1. Recommended wall opening for the damper installation is B (H) + 80 mm. Insert damper into wall to the wall limit mark **(7)** on the damper and bend the fixing bracket **(1)** 90°.

Damper blade must be closed during the installation!

2. Fix the damper to the wall with the screws. Bracket screw hole is 6 mm in diameter.

3. Fill the space between the damper and the wall with gypsum plaster **(2)**.

* Build the support for installation according to the drawing, [see page 10](#).

Test the operation of the damper blade!

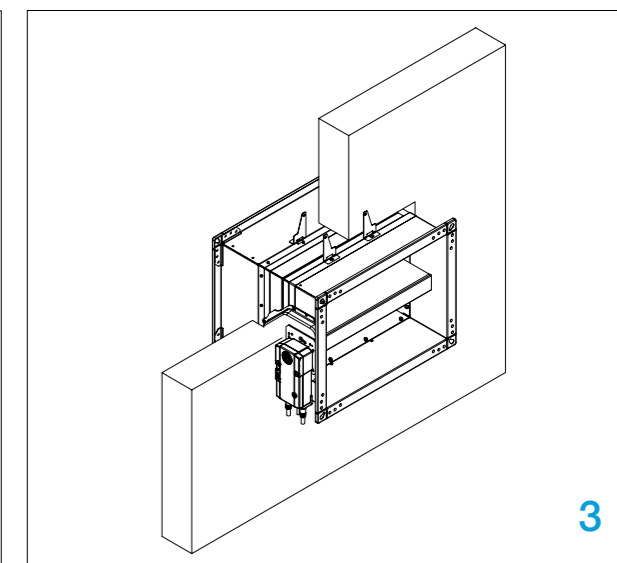
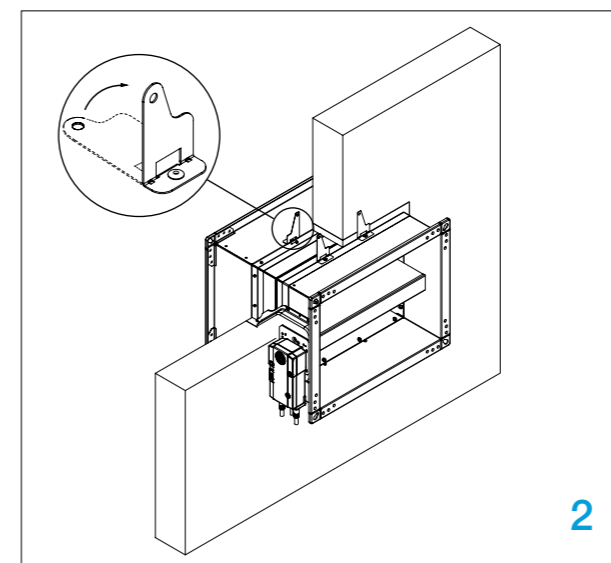
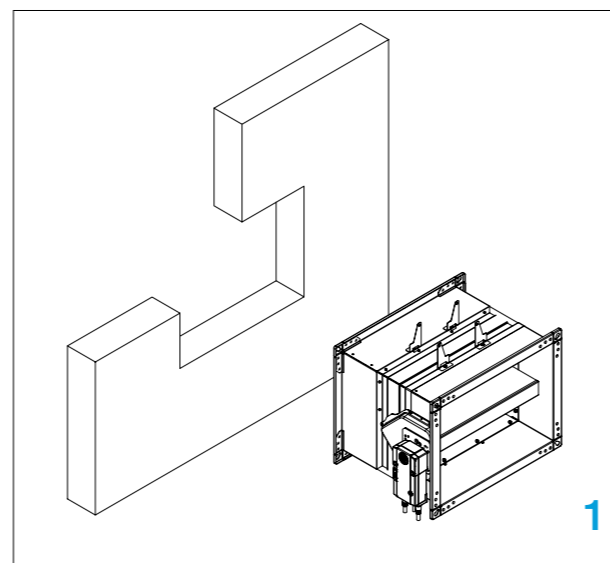

Flexible wall with type F gypsum plasterboards installation

The wall is made of 2x2 gypsum plasterboards, 12.5 mm thick, mounted on a steel structure. The wall is made of type F (EN520) gypsum plasterboards. The interior of the wall is uninsulated or with mineral wool with a density of up to 115 kg/m³. The installation material is gypsum lime plaster. Minimum wall thickness: 100 mm

* Create a substructure for the damper, [page 10](#).



INSTALLATION

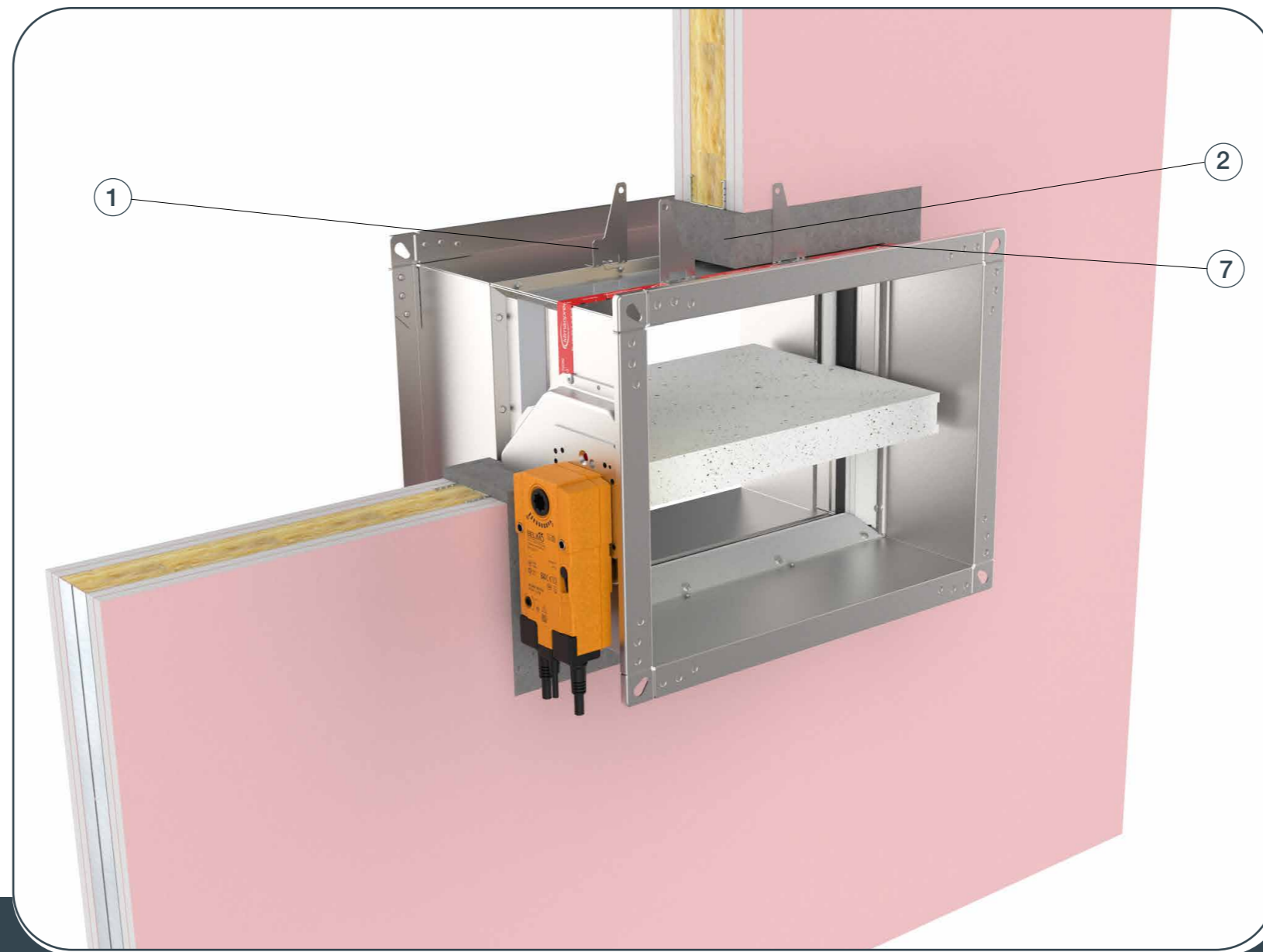

- ▼ [PRODUCT OVERVIEW](#)
- ▼ [DIMENSIONS](#)
- ▼ [INSTALLATIONS](#)
- ▼ [ACTUATORS](#)
- ▼ [REPLACEMENTS](#)
- ▼ [MAINTENANCE AND OPERATION](#)

SMOKE CONTROL DAMPERS

1. Recommended wall opening for the damper installation is B (H) + 80 mm. Insert damper into wall to the wall limit mark **(7)** on the damper and bend the fixing bracket **(1)** 90°.

Damper blade must be closed during the installation!

2. Fix the damper to the wall using 3.5x35 drywall screws, the hole in the bracket is 6 mm in diameter.

3. Fill the space between the damper and the wall with gypsum plaster **(2)**.

* Build the support for installation according to the drawing, [see page 10](#).

Test the operation of the damper blade!

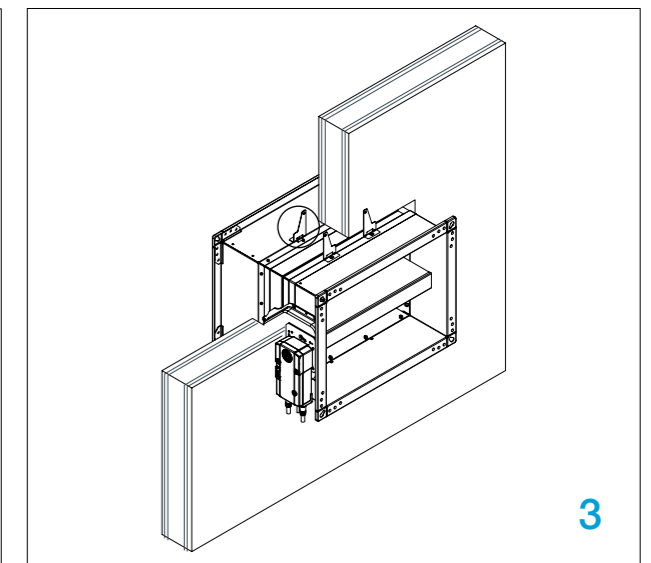
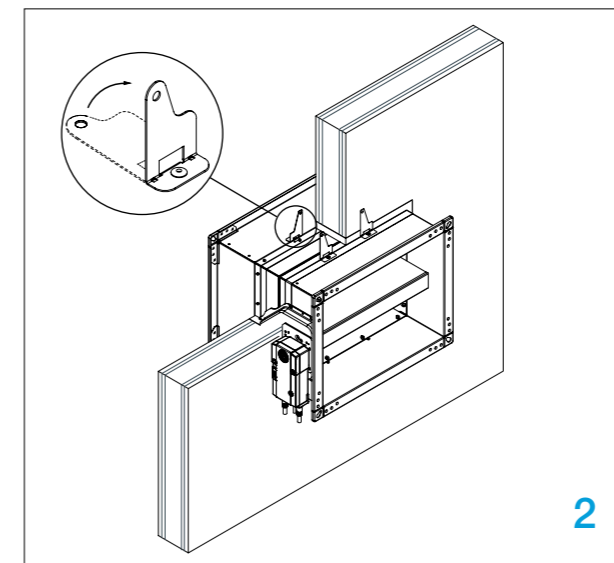
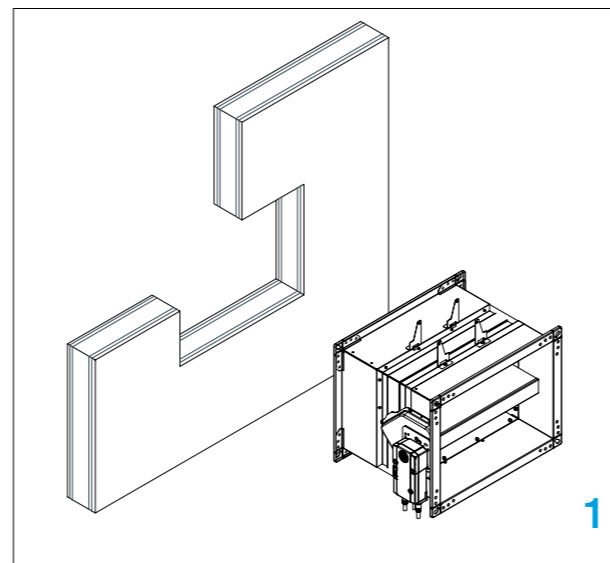

Rigid wall installation (gypsum plaster sealing)

Duct from one side

Rigid wall (aerated concrete, reinforced concrete, gypsum blocks, etc.) with minimum density of 450 kg/m³ and minimum thickness of 100 mm. Installation material: gypsum plaster.

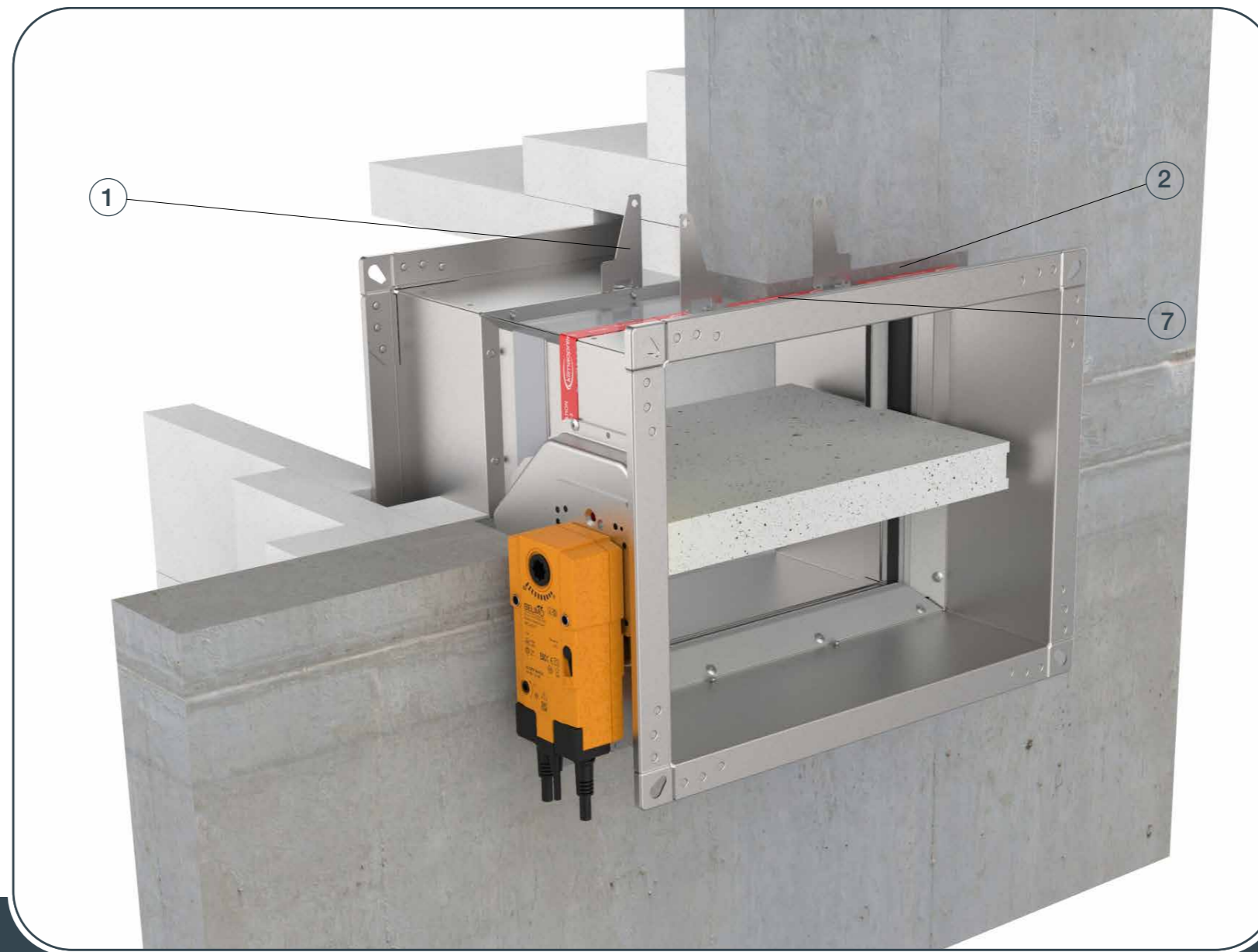

- ▼ [PRODUCT OVERVIEW](#)
- ▼ [DIMENSIONS](#)
- ▼ [INSTALLATIONS](#)
- ▼ [ACTUATORS](#)
- ▼ [REPLACEMENTS](#)
- ▼ [MAINTENANCE AND OPERATION](#)



INSTALLATION

SMOKE CONTROL DAMPERS

1. Recommended wall opening for the damper installation is B (H) + 80 mm. Insert damper into wall to the wall limit mark **(7)** on the damper and bend the fixing bracket **(1)** 90°.

Damper blade must be closed during the installation!

2. Fix the damper to the wall with the screws. Bracket screw hole is 6 mm in diameter.

3. Fill the space between the damper and the wall with gypsum plaster **(2)**.

* Build the support for installation according to the drawing, [see page 10](#).

* Build a channel support according to the drawing, [see page 15](#).

Test the operation of the damper blade!

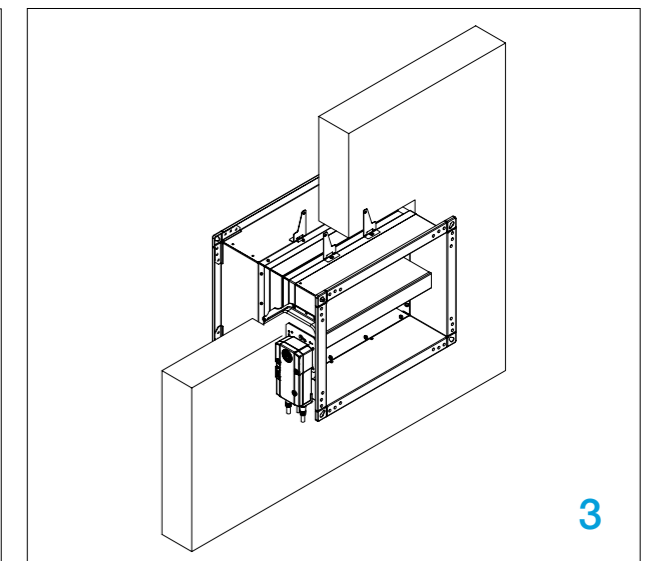
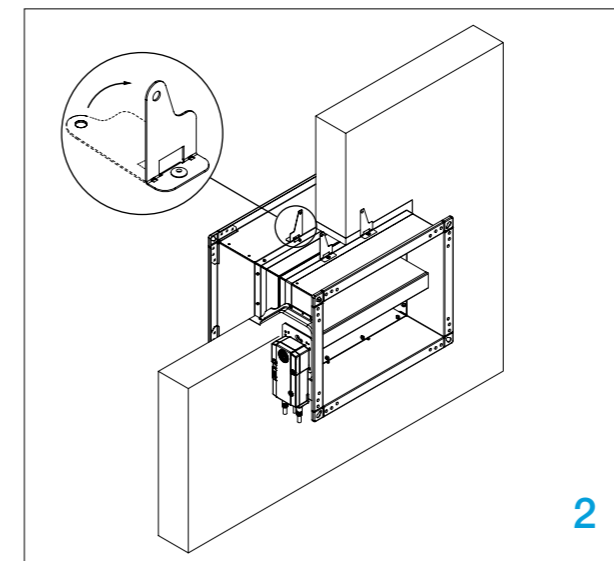
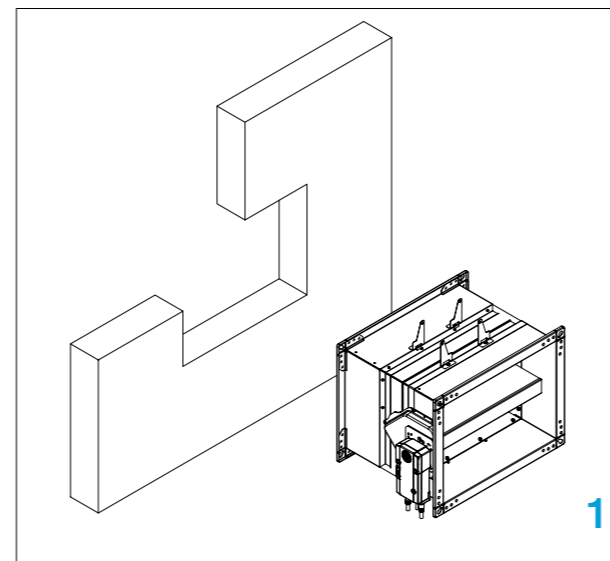

Rigid wall installation (gypsum plaster sealing)

Duct from both sides

Rigid wall (aerated concrete, reinforced concrete, gypsum blocks, etc.) with minimum density of 450 kg/m³ and minimum thickness of 100 mm.
Installation material: gypsum plaster.

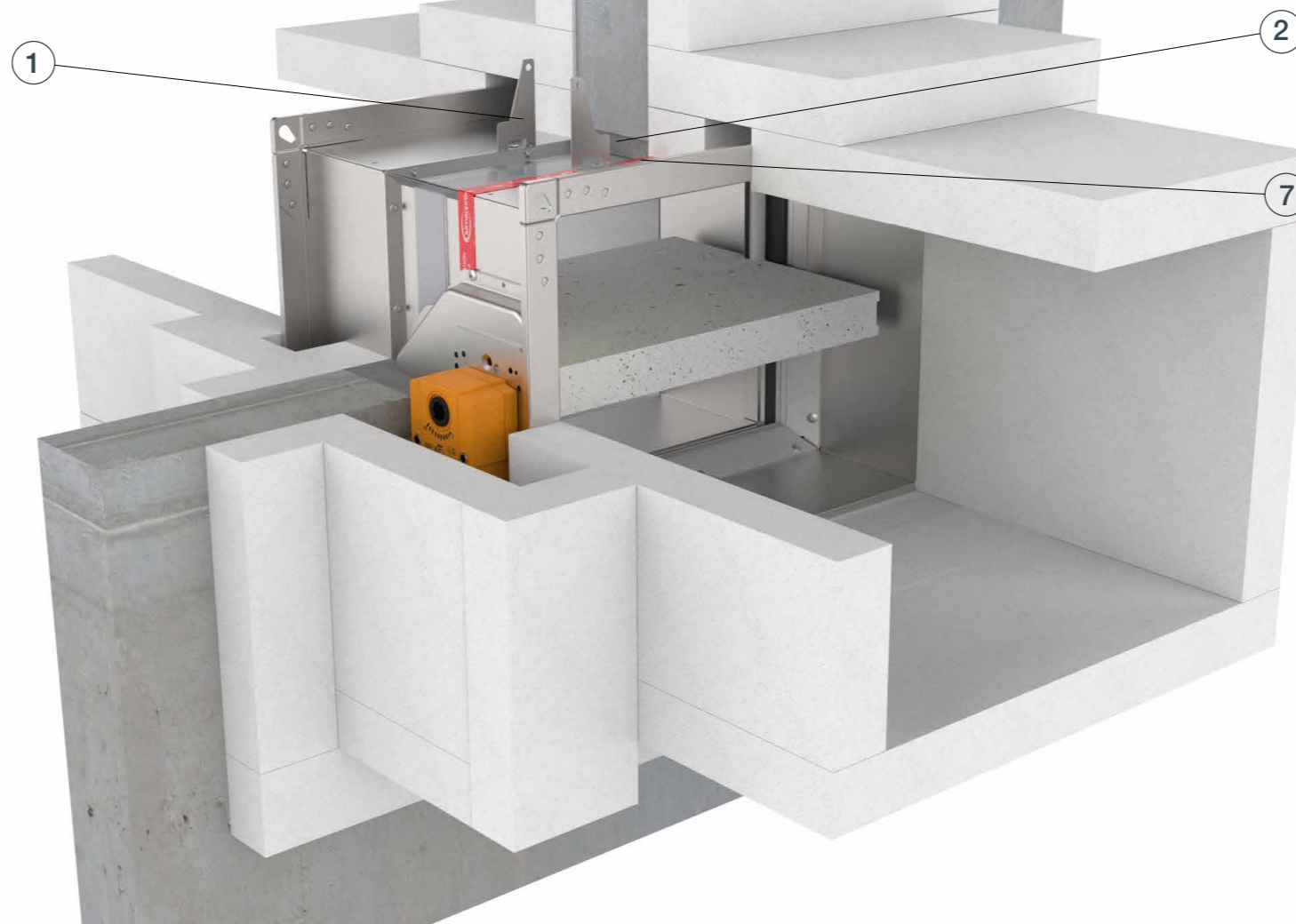

- ▼ [PRODUCT OVERVIEW](#)
- ▼ [DIMENSIONS](#)
- ▼ [INSTALLATIONS](#)
- ▼ [ACTUATORS](#)
- ▼ [REPLACEMENTS](#)
- ▼ [MAINTENANCE AND OPERATION](#)



INSTALLATION

SMOKE CONTROL DAMPERS

1. Recommended wall opening for the damper installation is B (H) + 80 mm. Insert damper into wall to the wall limit mark **(7)** on the damper and bend the fixing bracket **(1)** 90°.

Damper blade must be closed during the installation!

2. Fix the damper to the wall with the screws. Bracket screw hole is 6 mm in diameter.

3. Fill the space between the damper and the wall with gypsum plaster **(2)**.

* Build the support for installation according to the drawing, [see page 10](#).

* Build a channel support according to the drawing, [see page 15](#).

Test the operation of the damper blade!

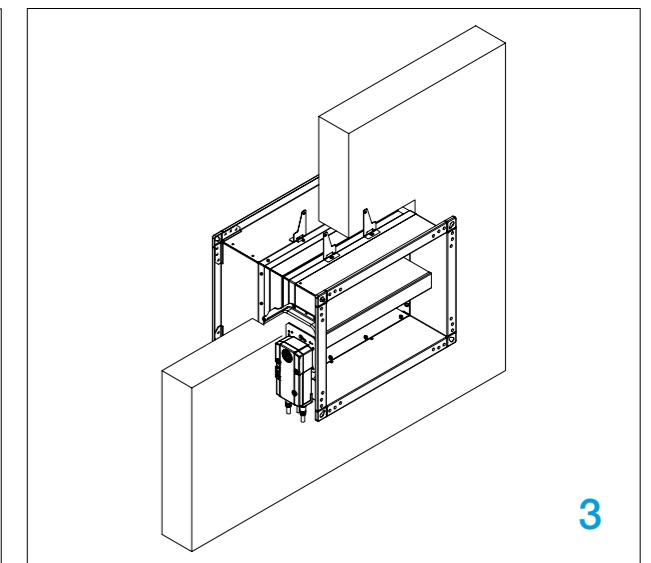
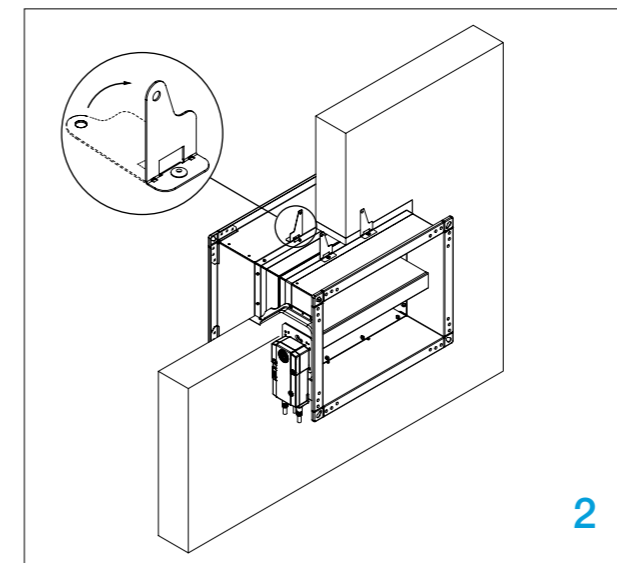
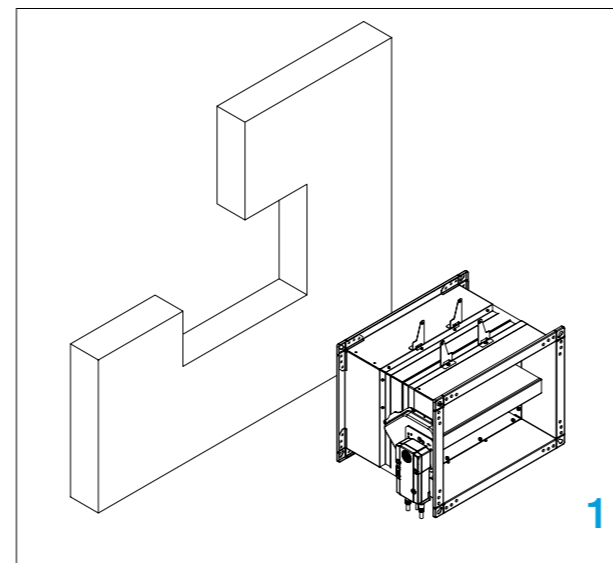

Rigid wall installation

Duct from one side

- 1 - FDSD smoke damper
- 2 - Gypsum plaster
- 3 - Solid wall
- 4 - Promatect L500 50mm strip
- 5 - Promatect L500 50mm strip
- 6 - Promatect L500 50mm board
- 7 - Fire-resistant smoke extract duct
- 8 - Dry wall screw / staple

WARNING: All duct connection surfaces are glued together with Promat K84 and fixed with screws and/or staples!

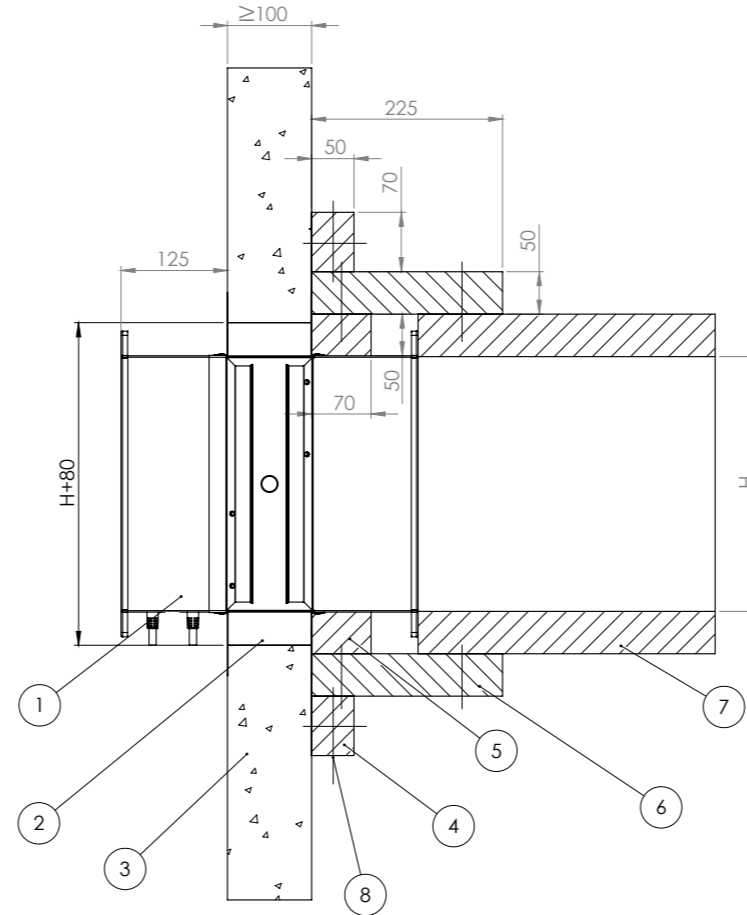

Rigid wall installation

Duct from both sides

- 1 - FDSD smoke damper
- 2 - Gypsum plaster
- 3 - Solid wall
- 4 - Promatect L500 50mm strip
- 5 - Promatect L500 50mm strip
- 6 - Promatect L500 50mm board
- 7 - Fire-resistant smoke extract duct
- 8 - Dry wall screw / staple

WARNING: All duct connection surfaces are glued together with Promat K84 and fixed with screws and/or staples!

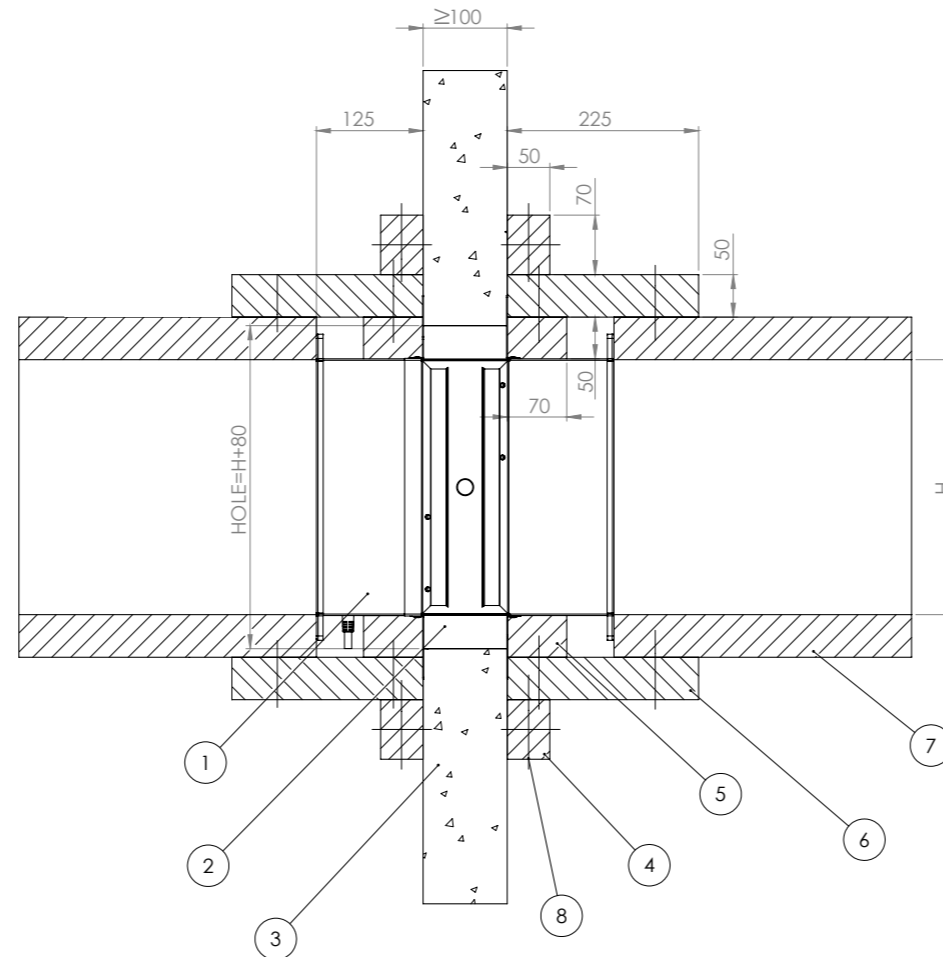

- ▼ [PRODUCT OVERVIEW](#)
- ▼ [DIMENSIONS](#)
- ▼ [INSTALLATIONS](#)
- ▼ [ACTUATORS](#)
- ▼ [REPLACEMENTS](#)
- ▼ [MAINTENANCE AND OPERATION](#)



INSTALLATION

SMOKE CONTROL DAMPERS

Connecting to sheet steel metal duct

1. Smoke damper
2. Flexible connector
3. Sheet steel smoke extract duct

In case of fire, there is an expansion of the ducts, therefore it is necessary to install a flexible connection for connecting ducts with smoke damper.

* Flexible connectors should meet the specifications for the sheet metal smoke duct.

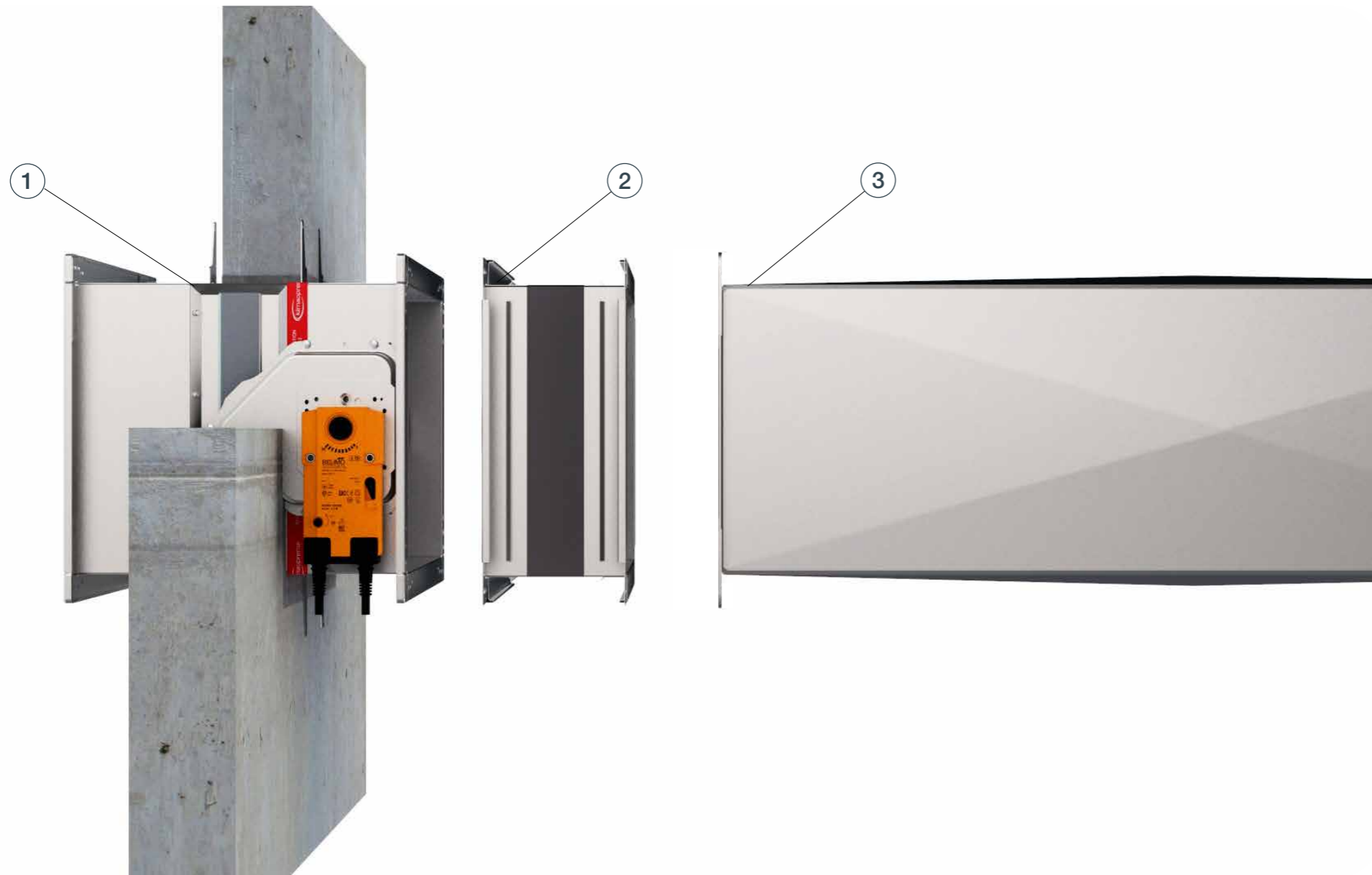

- ▼ [PRODUCT OVERVIEW](#)
- ▼ [DIMENSIONS](#)
- ▼ [INSTALLATIONS](#)
- ▼ [ACTUATORS](#)
- ▼ [REPLACEMENTS](#)
- ▼ [MAINTENANCE AND OPERATION](#)



SMOKE CONTROL DAMPERS

Vertical on duct installation

Duct is defined as a fire resistant smoke extract duct, tested according to EN1366-8 or EN1366-9, made of boards from Promat Promatect L500.



INSTALLATION

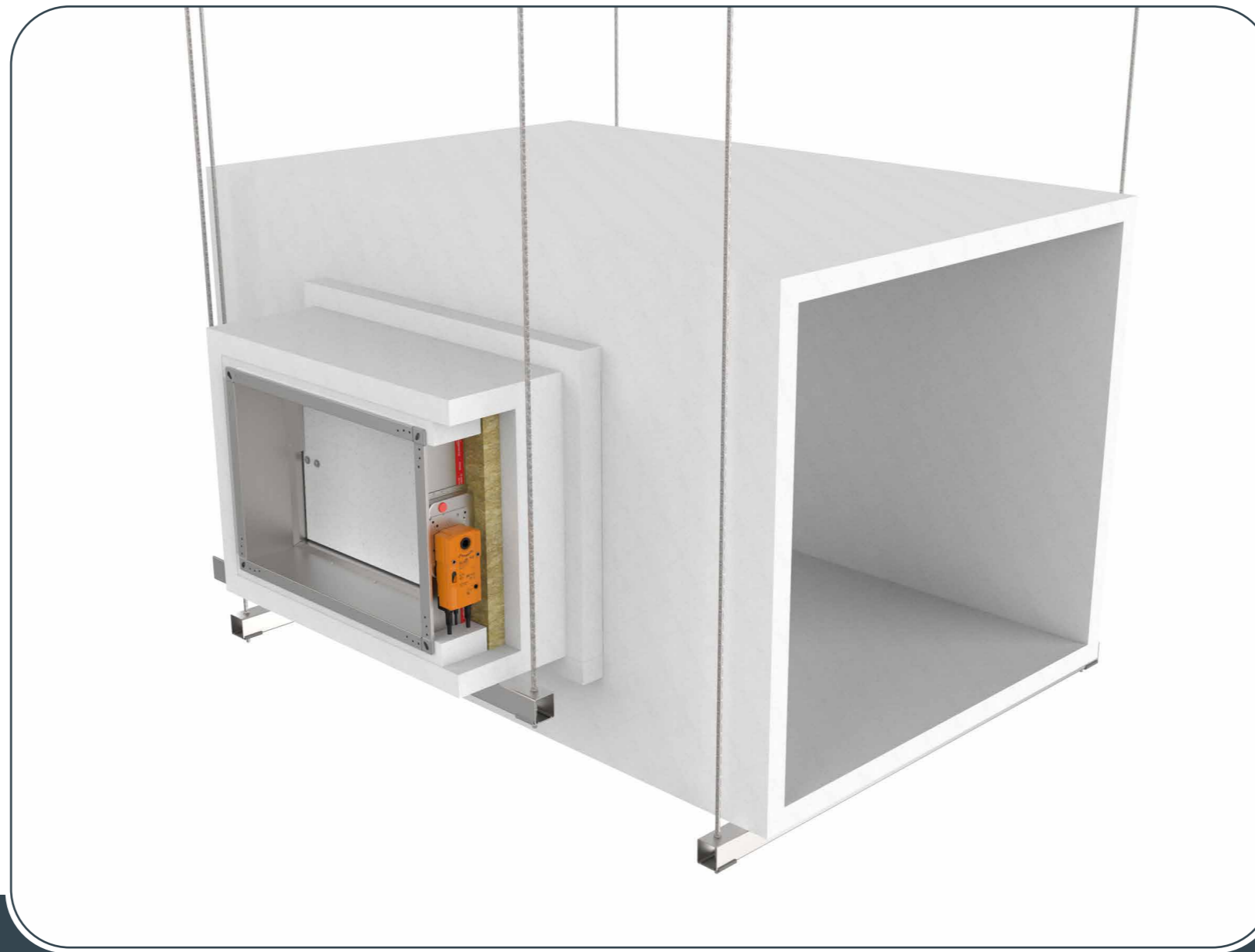

- ▼ [PRODUCT OVERVIEW](#)
- ▼ [DIMENSIONS](#)
- ▼ [INSTALLATIONS](#)
- ▼ [ACTUATORS](#)
- ▼ [REPLACEMENTS](#)
- ▼ [MAINTENANCE AND OPERATION](#)

SMOKE CONTROL DAMPERS

1. Remove the hangers and drill $\varnothing 4$ holes around the perimeter of the flange on the side opposite the actuator (distance between holes 150 - 200 mm). Place the silicone around the opening (where the flange of the damper will come), and then fix the damper to the duct with dry construction screws 3.5x40mm

Damper blade must be closed during the installation!

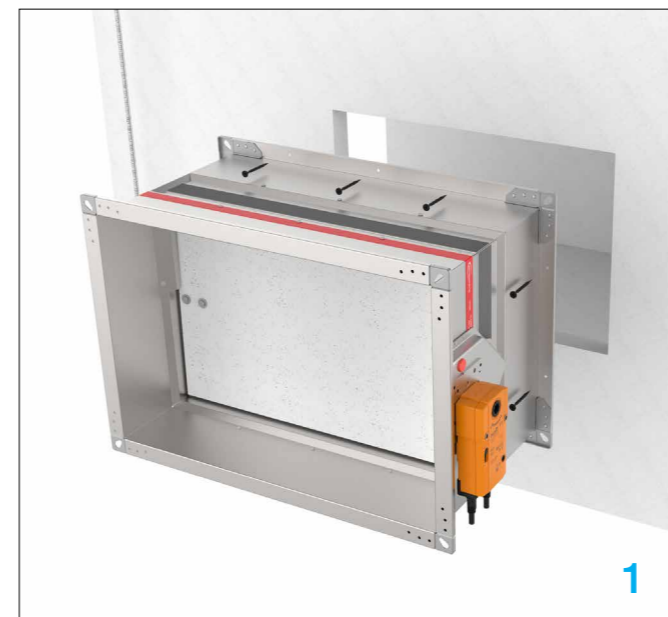
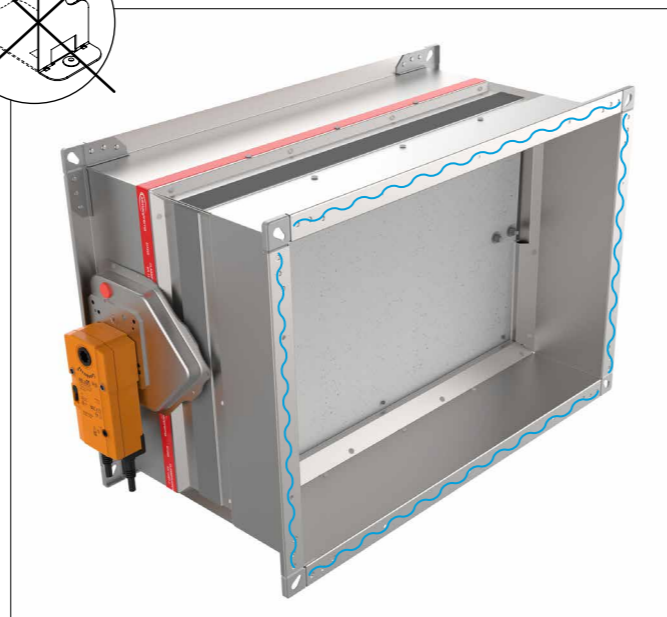
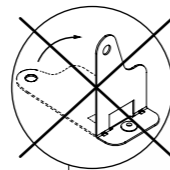

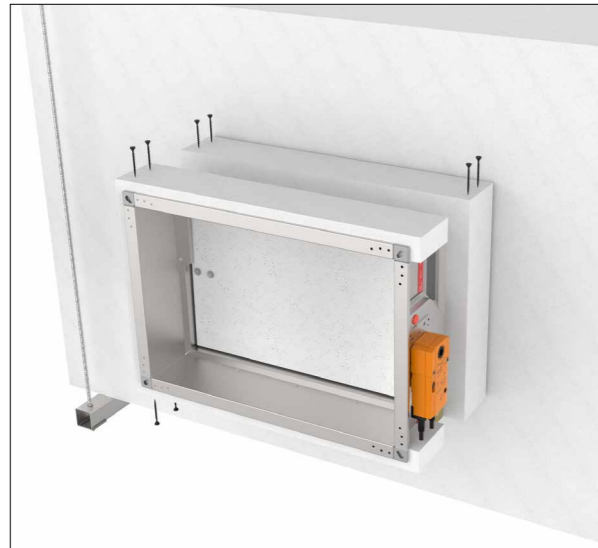

2. Cut the inner strips from the board (Promat Promatect L500 or similar, 50 mm thick) and connect them with 6x80mm screws as in the picture. 3 strips are placed closer to the actuator, and 4 strips are placed further from the actuator, as in the picture. Fill the space between with mineral wool with a density of 80 kg/m³.

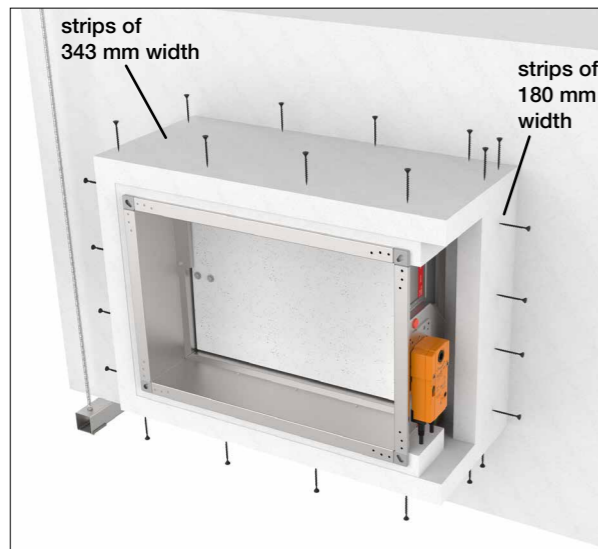

3. Cut the outer strips from the board and connect them with 6x80mm screws as in the picture (Distance between screws is 100-200mm). Strip of 180 mm width are placed closer to the actuator, and strips of 343 mm width are placed around 3 left sides of damper, as in the picture.

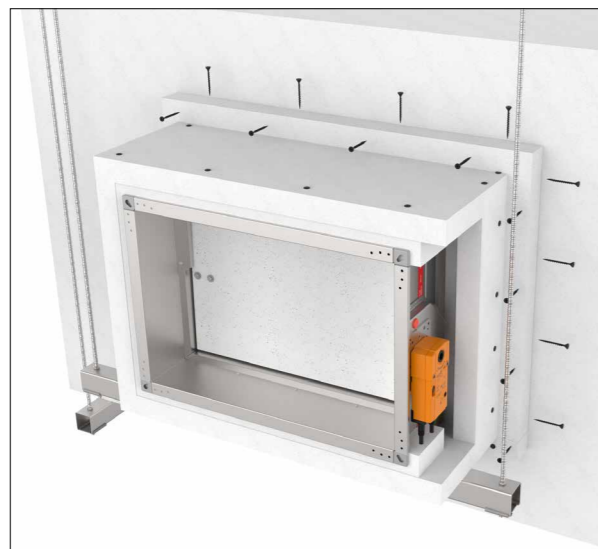

4. Screw strip 50x50mm around whole preimeter of the frame with screws 6x80mm. Distance between screws is 100-200mm and screws should go in direction of the duct and the casign.

Test the operation of the damper blade!

All connection must be covered with Promat Kleber K84 or similar glue!

Duct and damper must be suspended separately. Damper must not bear the weight of the duct and vice versa.

- ▼ [PRODUCT OVERVIEW](#)
- ▼ [DIMENSIONS](#)
- ▼ [INSTALLATIONS](#)
- ▼ [ACTUATORS](#)
- ▼ [REPLACEMENTS](#)
- ▼ [MAINTENANCE AND OPERATION](#)



SMOKE CONTROL DAMPERS

Vertical on duct installation

Duct is defined as a fire resistant smoke extract duct, tested according to EN1366-8 or EN1366-9, FIRESAFE FIRE RATED DUCTWORK, LTD – CF/EN/ E120/I120/GS/CT18/R



INSTALLATION

1. FDS smoke control damper is fixed to the side of the duct with a 30 mm wide flanges with nut-bolts M10 in the spacing of 150 mm around the perimeter of the flanges with a high-temperature gasket Caswell Fire 14 - Kerafix between the flanges of the damper and duct. The flanges are fixed together by using DIN933 M10x30 bolts and DIN934 M10 nut, at a minimum of 150mm between the bolts around the perimeter using the corner positions as a starting point..

Damper blade must be closed during the installation!

2. FDS smoke control damper is suspended on two threaded rods M10 and C-profiles MPC 38/40 placed on the top and bottom of the damper. The gypsum plate type F 12,5 mm thick with dimensions (B-20)x 80 mm is placed between the damper and C-profiles on both sides (top and bottom). Center of the gypsum plate is located in the center of the damper depth. Hangers of the damper are rotated so that the plate can be placed.

3. Cover the damper and the duct with mineral wool FIREPRO® DuctRock® Slab (manufacturer: ROCKWOOL) with a thickness of 90 mm and bulk density of 180kg/m³. The entire external surface of the damper up to the unconnected flange, except the actuator side where the insulation extends to the actuator, is covered with duct insulation.

Fasten the wool on the damper in the same way as on the duct (pin welding system).

Duct and damper must be suspended separately. Damper must not bear the weight of the duct and vice versa.

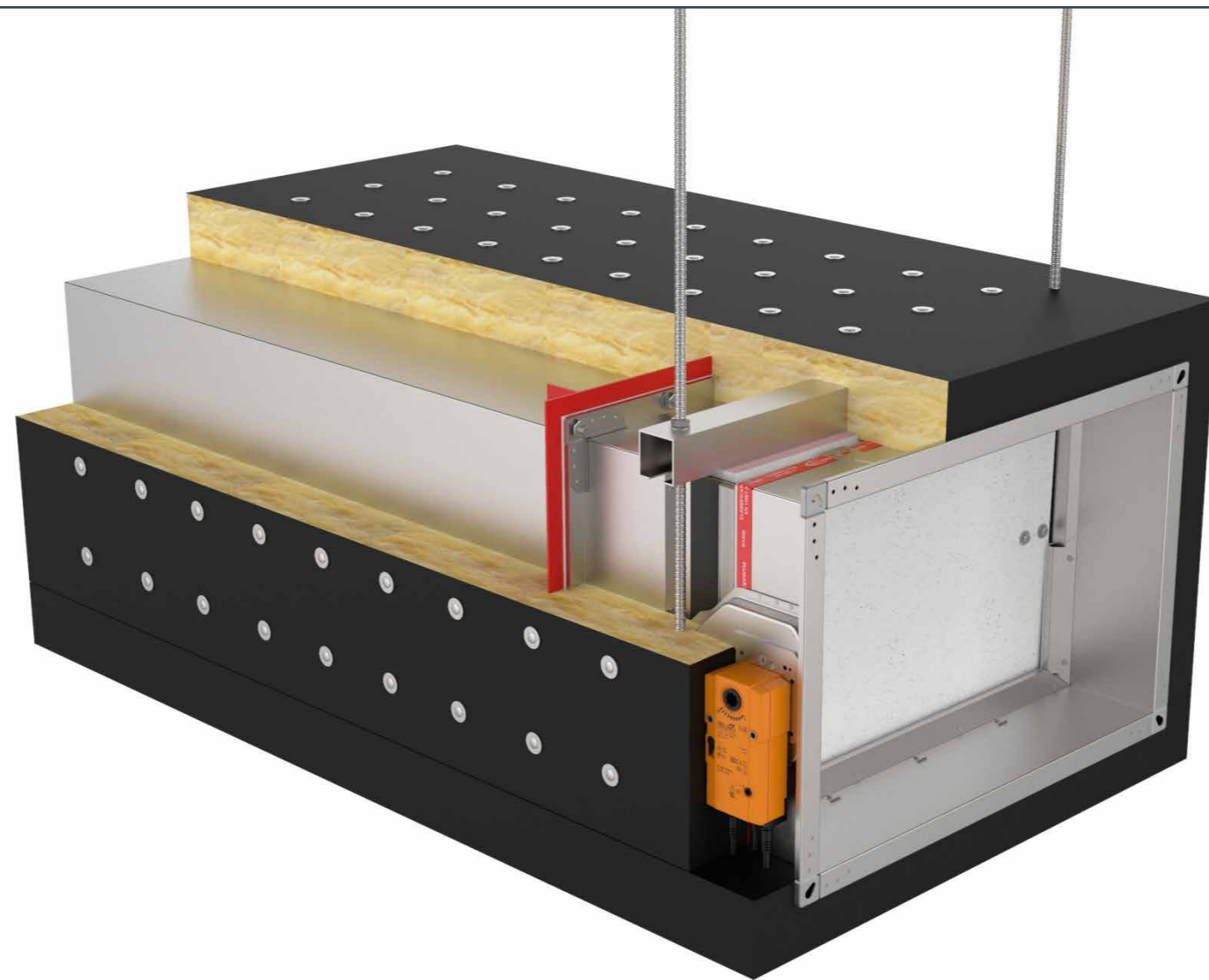

- ▼ [PRODUCT OVERVIEW](#)
- ▼ [DIMENSIONS](#)
- ▼ [INSTALLATIONS](#)
- ▼ [ACTUATORS](#)
- ▼ [REPLACEMENTS](#)
- ▼ [MAINTENANCE AND OPERATION](#)

SMOKE CONTROL DAMPERS

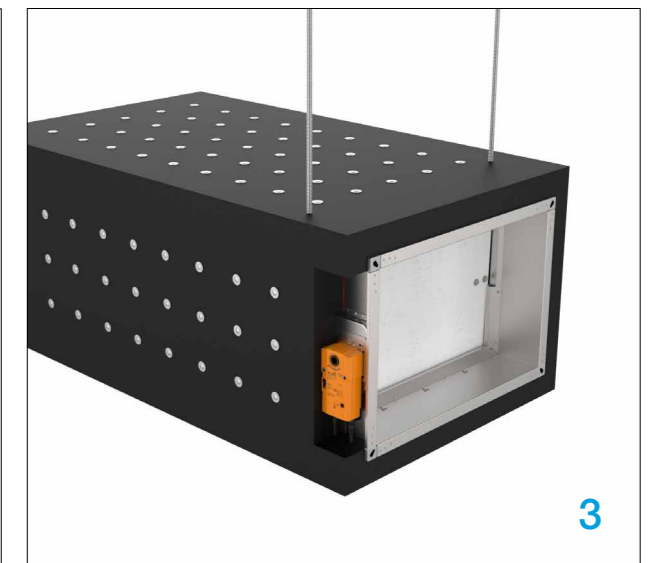
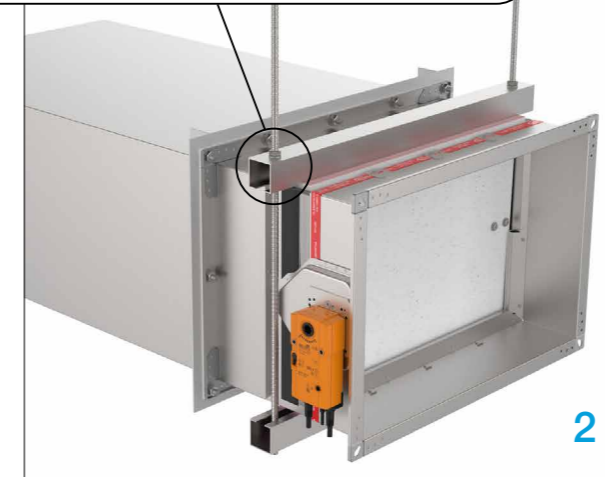
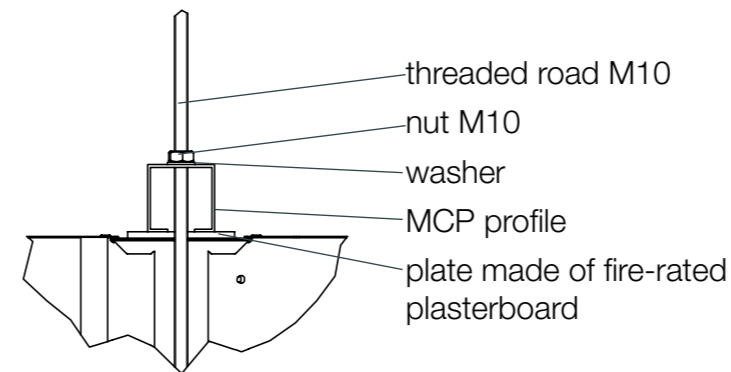
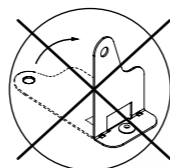

Minimal installation distances

Smoke control damper can be installed with minimal distance of 75 mm between wall/ceiling and 200 mm from other dampers.

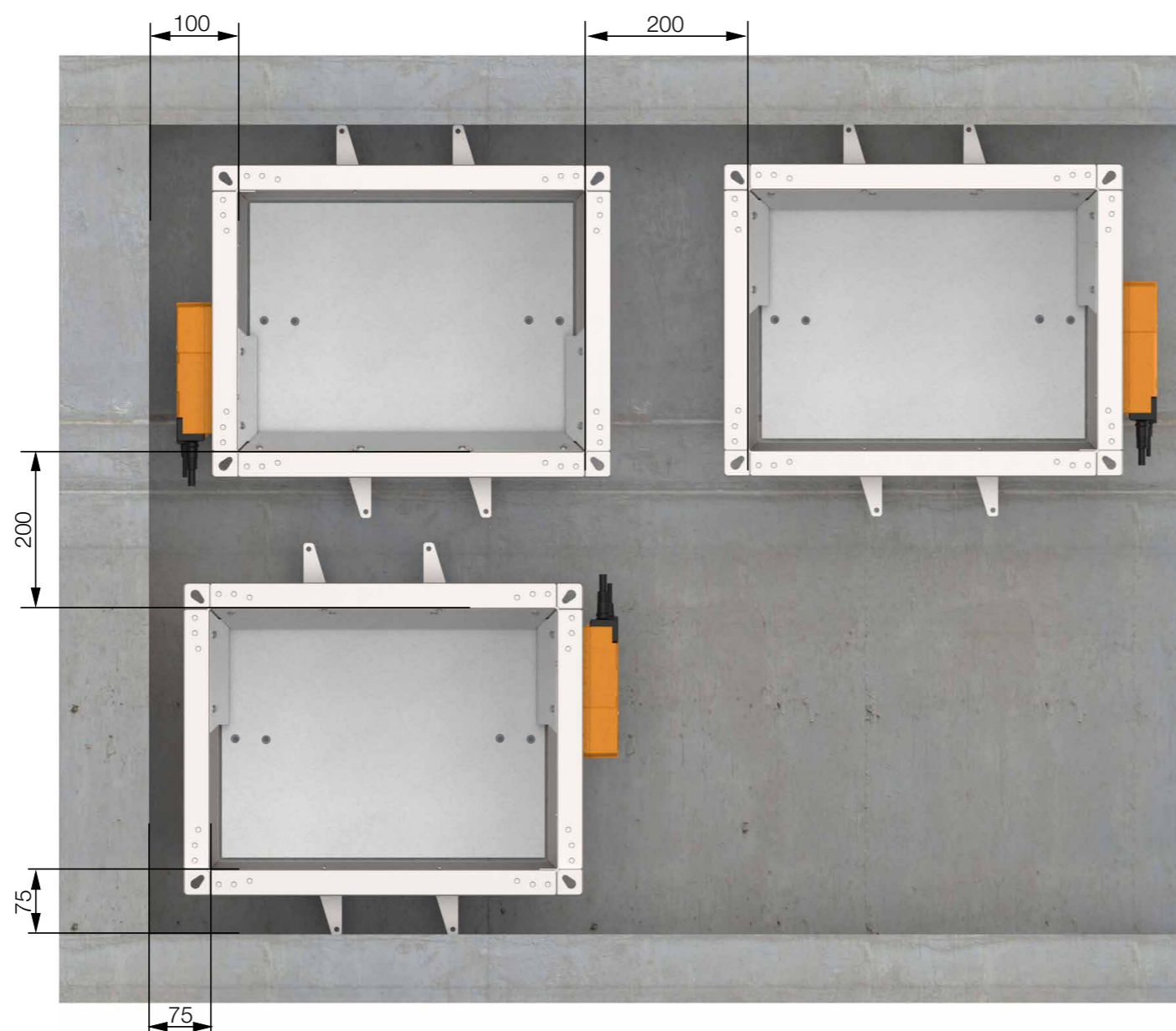

*Minimal distances from another damper or wall/ceiling.

- ▼ [PRODUCT OVERVIEW](#)
- ▼ [DIMENSIONS](#)
- ▼ [INSTALLATIONS](#)
- ▼ [ACTUATORS](#)
- ▼ [REPLACEMENTS](#)
- ▼ [MAINTENANCE AND OPERATION](#)



SMOKE CONTROL DAMPERS

ELECTRIC ACTUATOR

BEN 24, BEN 24-SR
BEN 230, BEE 24,
BEE 24-SR, BEE 230

Damper is delivered in closed position. The actuator features 2-wire open/close control. Actuator is overload proof and can remain energized at the end stops. Safety position lock enables the actuator to hold the damper in the defined safety position in case of fire.

Two microswitches with fixed settings are installed in the actuator for indicating the damper end positions. It should be noted in this application, however that the contacts can no longer be used in the milliamperere range after larger currents have been applied to them, even if this has taken place only once. The position of the damper blade can be read off on a mechanical position indication. Manual operation is possible with the hand crank that is provided with the actuator.



- ▼ [PRODUCT OVERVIEW](#)
- ▼ [DIMENSIONS](#)
- ▼ [INSTALLATIONS](#)
- ▼ [ACTUATORS](#)
- ▼ [REPLACEMENTS](#)
- ▼ [MAINTENANCE AND OPERATION](#)

Wiring diagram BEN 24/ BEN 230/ BEE 230

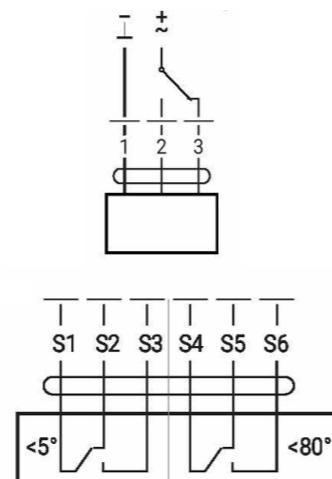

1	black
2	red
3	white
S1	violet
S2	red
S3	white
S4	orange
S5	pink
S6	grey

Wiring diagram BEE 24-SR/ BEN 24-SR

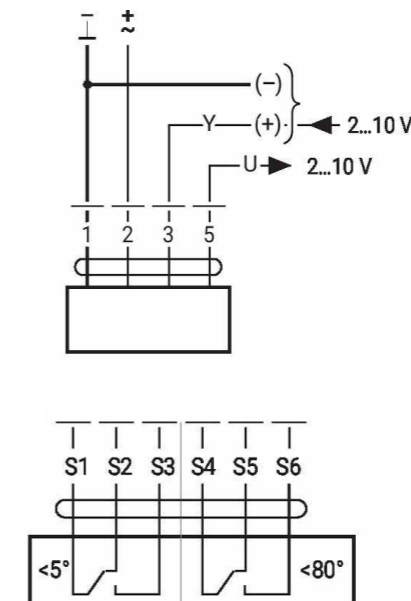

1	blue
2	brown
3	white
S1	violet
S2	red
S3	white
S4	orange
S5	pink
S6	grey

Technical specifications

Type of Belimo actuator	BEN 24 / BEN 24-SR	BEN 230	BEE 24 / BEE 24-SR	BEE 230
Torque	15 Nm	15 Nm	25 Nm	25 Nm
voltage	AC/DC 24V 50/60 Hz	AC 230 V 50/60 Hz	AC/DC 24V 50/60 Hz	AC 230 V 50/60 Hz
Nominal voltage / power operation	3 W	4 W	2,5 W / 3 W	3,5 W
consumption rest position	0,1 W / 0,3 W	0,4 W	0,1 W / 0,3 W	0,4 W
Angle of Rotation	95°	95°	95°	95°
Running time	< 30 s / 90°		< 60 s / 90°	
Mechanical interface	Form fit 12x12 mm			
Control	Open-close, modulating			

HOW TO ROTATE ELECTRIC ACTUATOR (Belimo)

200x200 to 1500x800

The blade must be closed before replacement the mechanism.

ERK Kit (FD-A-ERK)

- transition plate
- rectangular shaft
- 2x screws M6x30



- ▼ [PRODUCT OVERVIEW](#)
- ▼ [DIMENSIONS](#)
- ▼ [INSTALLATIONS](#)
- ▼ [ACTUATORS](#)
- ▼ [REPLACEMENTS](#)
- ▼ [MAINTENANCE AND OPERATION](#)

1) Locate the 2 hex screws, unscrew and remove actuator.

2) Remove FA transition plate and rectangular shaft.

3) Insert new transition plate and rectangular shaft from ERK kit.

NOTE

A Pay attention to the position of the indicator cut!
B Pay attention to the indicator cut, insert the ERK rectangular shaft that a smaller portion of the shaft enters ERK transition plate!

4) Fix the transition plate to the transition board and install the Belimo actuator.

Test the operation of the damper blade!

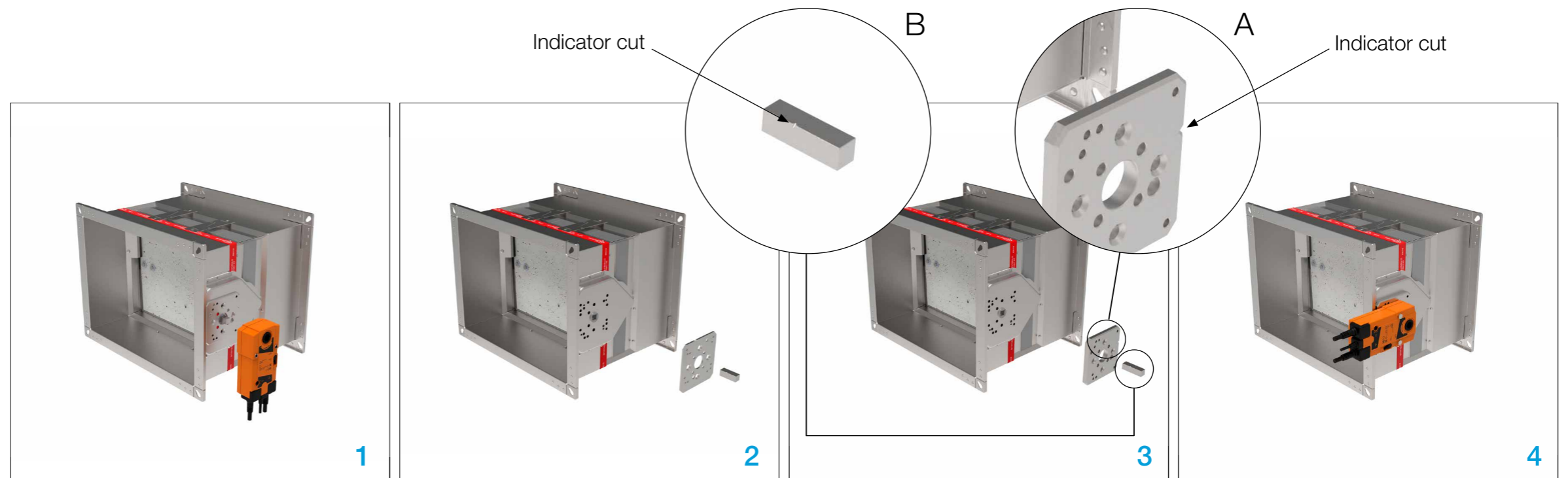



- ▼ [PRODUCT OVERVIEW](#)
- ▼ [DIMENSIONS](#)
- ▼ [INSTALLATIONS](#)
- ▼ [ACTUATORS](#)
- ▼ [REPLACEMENTS](#)
- ▼ [MAINTENANCE AND OPERATION](#)



TRANSPORT

After arrival, check the smoke control damper for transport damage and shortcomings. In case of any damage or shortcomings, immediately contact your supplier.

STORAGE

If the damper is not installed immediately

- Remove any wrapping.
- Protect damper from dust and contamination.
- Do not expose the product to the effects of weather - store smoke control damper in dry place.
- Do not store the unit below -20 °C or above 50 °C.

Please properly dispose of packaging material!

WARNING!

Danger of electric shock! Do not touch any live components! Electrical equipment carries a dangerous electrical voltage. Switch off the power supply before working on any electrical equipment!

MAINTENANCE AND CLEANING

FDSD is maintenance free. Our smoke control dampers can be wiped (dust, ...) with a wet or dry cloth and additionally vacuumed with an industrial vacuum cleaner, except for electronic parts. To avoid damage to the blades and bearings, use soft cloths.

Never use chlorine-based corrosive agents!

COMMISSIONING

Carefully unpack FDSD smoke control damper - be careful of sharp edges and do not use excessive force for unpacking. Wear protective gloves, safety shoes and a hard hat.

- Inspect the product - check the smoke damper for damage
- Installation of the smoke control damper - according to the installation instructions.

FUNCTIONS

Functional reliability must be controlled or tested every six months. If two consecutive tests are successful, the next functional test can be performed in one year.

Functionality testing must be carried out in accordance with the following norms:

- EN 12101-8
- EN 13306
- EN 15423
- According to the norms represented in the country of installation

Never use the smoke control damper:

- in areas with potentially explosive atmospheres
- outdoors without sufficient protection against the effects of weather and outside of temperature limits
- in atmospheres where chemical reactions, whether planned or unplanned, may cause damage to the smoke control damper or lead to corrosion



FIRE DAMPER - FD

 Joseph Wilson Industrial Estate, Whitstable, CT5
 3DU UK+44 (0) 1634
 actionair@swegon.com
 www.swegon.com/uk/
