



Product manual

ThermShield FDC EIS Classified Fire Damper

Fire protection

Version 3.0
Issue Date: 10.03.2025.

1. Gypsum layers
2. Intumescent strip
3. Cold smoke seal
4. Contact layer

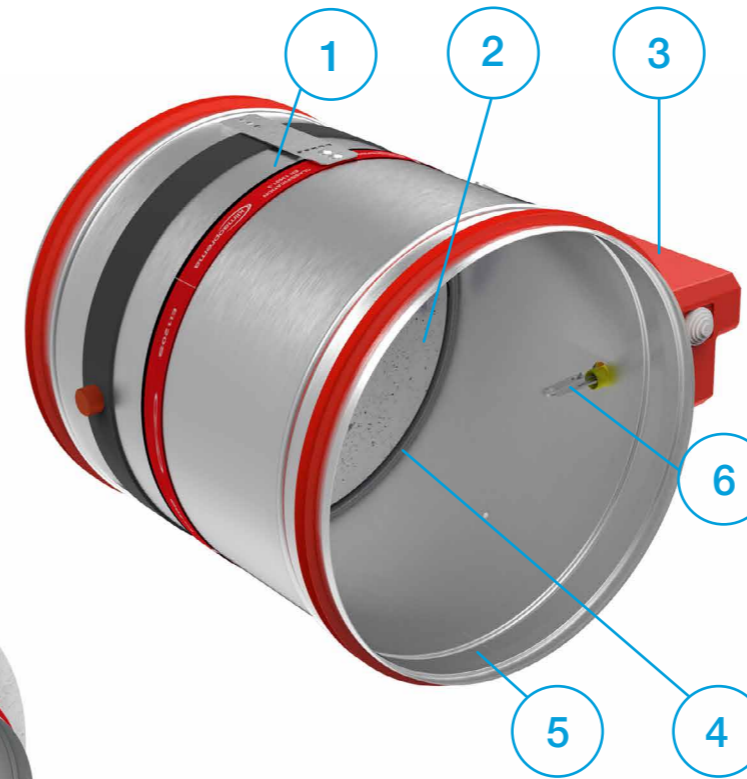
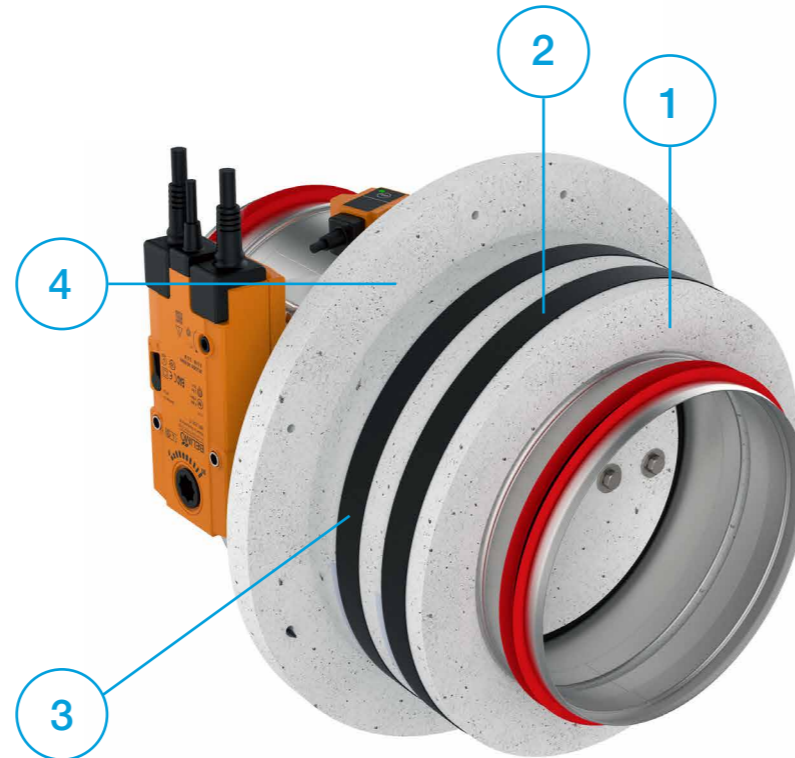

1. Galvanized steel casing
2. Fire resistant damper blade
3. Actuator
4. Intumescent joint
5. Connection flanges
6. Thermal fuse

- ▼ [PRODUCT OVERVIEW](#)
- ▼ [DIMENSIONS](#)
- ▼ [INSTALLATIONS](#)
- ▼ [ACTUATORS](#)
- ▼ [ACCESSORIES](#)
- ▼ [REPLACEMENTS](#)
- ▼ [MAINTENANCE AND OPERATION](#)

PRODUCT OVERVIEW

Fire dampers FDC are used for prevention of fire spread through the ventilation ducts and between fire sections. Fire dampers consist of steel sheet casing, calcium silicate damper blade, damper blade mechanism outside of the airflow and a manual, electromagnetic or electric actuator.

Fire damper casing is made out of galvanized steel sheet. Variants produced from stainless steel and powder coated steel are also available. Calcium silicate blade is equipped with brass bearings and seals made out of polyurethane and elastomer rubber.

Fire dampers FDC25 are produced up to size d315 and have 25 mm thick damper blade. Fire dampers FDC40 are produced in sizes from d355 till d800 and have 40 mm thick damper blade.

FDC25 fire dampers are equipped with R25 manual mechanism and FDC40 fire dampers are equipped with R40 manual mechanism.

Manual spring return mechanism is equipped with thermal fuse that is triggered automatically when the temperature inside the duct reaches 72 °C. It can also be activated manually by the push of the button on the mechanism ([see page 56.](#)). Additional equipment for manual mechanism include end contact switches for damper position signalling. Electromagnetic actuators feature spring return mechanism with electromagnet for remote activation. Additional equipment for electromagnetic mechanism include end contact switches for damper position signalling. Rearming of the electromagnetic actuator is manual.

Fire dampers with electric actuators are equipped with Belimo actuator drives in 24 V or 230 V versions. Activation of fire dampers equipped with electric drives can be via 72 °C or 95 °C thermal fuse or remotely via control signal. Rearming of the electric fire damper can also be done remotely via control signal. All electric actuators are equipped with end switches for position signalling.

ATEX rated versions of fire dampers can be delivered with Schischek 24 V / 230 V electric actuators that are rated for installation in explosive atmosphere areas.

All fire dampers are tested according to the EN 1751 for airtightness and retain class 3 leakage on the closed damper blade and class C on the casing air leakage.

* The images shown are for illustration purposes only and may not be an exact representation of the product.

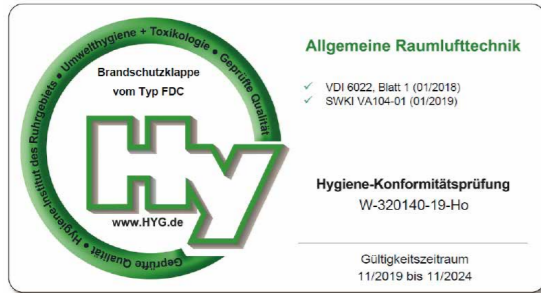

- ▼ [PRODUCT OVERVIEW](#)
- ▼ [DIMENSIONS](#)
- ▼ [INSTALLATIONS](#)
- ▼ [ACTUATORS](#)
- ▼ [ACCESSORIES](#)
- ▼ [REPLACEMENTS](#)
- ▼ [MAINTENANCE AND OPERATION](#)

TESTS AND CERTIFICATES

All our dampers are submitted to a number of tests by official test institutes. Reports of these tests form the basis for the approvals of our dampers. Fire dampers are also suitable for installation in buildings with high hygienic demands such as hospitals, clinics and pharmaceutical areas.

To confirm this, our products are tested by an independent Institute of Hygiene, based in Gelsenkirchen, Ruhr, and comply with directives and guidelines in VDI 6022.

Our FDC damper contains an EPD certificate. EPD or Environmental Product Declaration is a document that transparently communicates the performance or impact on the environment of any product or material during its lifetime. The EPD is usually valid for five years and is produced according to the relevant standards. The EPD is made in accordance with EN 15804+A2 & ISO 14025/ ISO 21930.

FIRE RESISTANCE CLASSIFICATION

FDC fire resistance is tested according to EN 1366-2 "Fire resistance tests for service installations- Part 2: Fire dampers". Classification of the fire dampers is defined according to EN 13501-3 Fire classification of construction products and building elements.

Installation in both, vertical and horizontal axis of rotation of the dampers blade is acceptable (with the axis angle 0 - 360°). Fire resistance of fire damper depends on classification of walls or ceilings. It is allowed to install products to walls or ceilings only according to products Declaration of Performance. Walls or ceilings with greater fire resistance can also be used. Fire damper should be installed according to the installation manual which can be found within this document.

Please consult latest Declaration of Performance:

For more information about certificates, visit our website.

- E - Integrity
- I - Insulation
- 120/90/60** - Classification time in minutes
- S - Smoke leakage
- ve** - Damper installed in vertical compartment
- ho** - Damper installed in horizontal compartment
- i→o** - Fire performance criteria are met on both sides



TECHNICAL DATA

Fire damper casing is manufactured from galvanized steel sheet, but on demand can be produced out of:

- Galvanized steel and powder coated
- Stainless steel EN 1.4301/EN 1.4404 (AISI 304/316L)
- Stainless steel EN 1.4301/EN 1.4404 (AISI 304/316L) and powder coated

** **Stainless steel not possible with MF1, MF2, Applique**

Fire damper for areas with potentially explosive atmospheres are also available



Product label

- Casing air leakage classification
- Serial number
- Production date
- Type
- Dimension of the fire damper
- Mechanism type
- Nominal voltage
- Signalisation (end contacts)
- IP protection
- Free space
- Thermal fuse temperature
- Number of the European standard and year of its publication
- Declaration of performance
- Classification according to EN 13501-3
- Barcode
- CE mark

Product specifications

Nominal sizes FDC	100 - 800 [mm]
Casing length	380 mm
Temperature range	-20 °C ... 50 °C
Release temperature	72 °C (standard) or 95 °C (optional with electric actuator)
Volume flow rate range	up to 21700 m³/h
Differential pressure range	up to 1000 Pa
Casing air leakage	Class C, EN 1751
Closed blade air leakage	Class 3, EN 1751
Upstream velocity	< 12 m/s
EC conformity	EN 13501-3, EN 1366-2, EN 15650, EN 1751, CPR no.305/2011
Declaration of performance	DoP 711

Pressure drop tables

Pressure drop values are described with the "Zeta" values for each size. The exact pressure drop in [Pa] is calculated using the following formula:

$$\Delta p \text{ [Pa]} = \zeta * v^2 * 0,6$$

where ζ is Zeta value from the tables below, v is airflow velocity in [m/s]

FDC25	d100	d125	d160	d200	d250	d315
ζ	1,759	0,852	0,545	0,445	0,340	0,293

FDC40	d355	d400	d450	d500	d560	d630	d710	d800
ζ	0,428	0,389	0,344	0,325	0,312	0,232	0,206	0,179

- PRODUCT OVERVIEW
- DIMENSIONS
- INSTALLATIONS
- ACTUATORS
- ACCESSORIES
- REPLACEMENTS
- MAINTENANCE AND OPERATION

CLASS C EN1751

actionair
by Swegon

SERIAL NUMBER: 201623500700001

PRODUCTION DATE: 11.03.2022

TYPE: FDC25 – d125 – R

DIMENSION: d125

ACT. MECHANISM: R

NOMINAL VOLTAGE: –

SIGNALISATION: No

LOCATION:

IP PROTECTION: IP42

FREE SPACE (dm2): 0.87

THERMAL FUSE: 72°C

USER MANUALS

EN15650:2010
Eltt(Ve – Ho) S Cxx
For fire classification of product
consult declaration of performance.
DOP 711/2020_12
EI60/90/120 (Ve Ho i < – > o)S 500Pa

PRODUCT MUST BE INSTALLED BY INSTRUCTIONS SUPPLIED BY MANUFACTURER

201623500700001

FIRE DAMPER - FDC

Dimensional range

	Diameter [mm]	Cross section [dm²]	Net area [dm²]
FDC25	100	0,74	0,50
	125	1,17	0,87
	160	1,93	1,55
	200	3,05	2,56
	250	4,79	4,18
	315	7,64	6,87
FDC40	355	9,73	8,33
	400	12,37	10,79
	450	15,69	13,91
	500	19,39	17,41
	560	21,71	19,49
	630	30,86	28,36
	710	39,24	36,42
	800	49,86	46,68

4

MODELS

Casings

FDC25

Cylindrical fire damper with 25 mm damper blade and fire classification up to EI120S. Sizes range from d100 till d315.

FDC40

Cylindrical fire damper with 40 mm damper blade and fire classification up to EI120S. Sizes range from d355 till d800.

FDC25 - APP

Cylindrical fire damper with integrated Applique installation frame with 25 mm damper blade and fire classification up to EI90S. Sizes range from d100 till d315.

FDC25 - MF1/MF2

Cylindrical fire damper with integrated MF1 installation frame with 25 mm damper blade and fire classification up to EI60S. Sizes range from d100 till d315.

FDC40 - MF2

Fire damper with integrated MF2 installation frame with 40 mm damper blade and fire classification up to EI90S. Sizes range from d355 till d800.



- ▼ [PRODUCT OVERVIEW](#)
- ▼ [DIMENSIONS](#)
- ▼ [INSTALLATIONS](#)
- ▼ [ACTUATORS](#)
- ▼ [ACCESSORIES](#)
- ▼ [REPLACEMENTS](#)
- ▼ [MAINTENANCE AND OPERATION](#)



PRODUCT OVERVIEW

FIRE DAMPER - FDC

Actuators

R (R-S)

Manual operating mechanism, optionally with end switches (R-S). In case of fire, the fire damper closes automatically. Damper closing can be initiated either by thermal fuse melting, or by manual activation on the operating mechanism. Upon closure, damper blade is locked in closed position and can only be opened manually (see page 56.). Thermal fuse melting point is 72 °C.

EMS-S

Electromagnetic operating mechanism, comes with end switches as standard. In case of fire, the fire damper closes automatically. Damper closing can be initiated either by thermal fuse melting or remotely by triggering the electromagnet. Electromagnet is constantly under power and activates closing of the damper blade in case the power cuts out. Upon closure, damper blade is locked in closed position and can only be opened manually (see page 56.). Thermal fuse melting point is 72 °C.

M230-S

Belimo 230 V electro motor operating mechanism, comes with integrated end switches. In case of fire, the fire damper closes automatically. Damper closing can be initiated either by thermoelectric release device or remotely by triggering the electro motor. Upon closure, damper blade is locked in closed position and can be opened by sending a signal to electro motor. Standard thermoelectric release point is 72 °C, optional 95 °C.

M24-S

Belimo 24 V electro motor operating mechanism, comes with integrated end switches. In case of fire, the fire damper closes automatically. Damper closing can be initiated either by thermoelectric release device or remotely by triggering the electro motor. Upon closure, damper blade is locked in closed position and can be opened by sending a signal to electro motor. Standard thermoelectric release point is 72 °C, optional 95 °C.

M24-S-ST

Belimo 24 V electro motor operating mechanism, comes with integrated end switches. In case of fire, the fire damper closes automatically. Damper closing can be initiated either by thermoelectric release device or remotely by triggering the electro motor. Upon closure, damper blade is locked in closed position and can be opened by sending a signal to electro motor. Standard thermoelectric release point is 72 °C, optional 95 °C. Actuator is additionally equipped with connection plug for easy connection with power supply and communication modules.

EX

ATEX rated fire dampers are equipped with Schischek ExMax-5.10-BF actuators, ExPro-TT thermal switches and ExBox-BF plenum boxes. Optional casing can be produced in AISI 316 stainless steel.

Ordering key

(1) Damper type (2) Dimension (3) Mechanism type (4) Mounted accessories

FDC25 - d250 - M230-S - IH

- | | |
|---|---|
| <p>(1) FDC25 - d100 to d315
 FDC40 - d355 to d800
 FDC25-APP - d100 to d315
 FDC25-MF1 - d100 to d315
 FDC25-MF2 - d100 to d315
 FDC40-MF2 - d355 to d800</p> <p>(2) Damper diameter
 d100 till d800</p> | <p>(3) R - manual drive
 R-S - manual drive with limit switches
 M230-S - electric actuator AC/DC 230 V
 M24-S - electric actuator AC/DC 24 V
 M24-S-ST - electric actuator AC/DC 24 V with connection plug
 EMS-S - electromagnetic drive
 EX - electric actuator Schischek ExMax -5.10-BF +ExPro-TT+ExBox-BF</p> <p>(4) IH - inspection hatch</p> |
|---|---|

FDC25/FDC40 - R (manual mechanism)

- Automatic closure when the temperature in the duct exceeds 72 °C
- Manual rearming
- Manual unlocking possible for periodical test of fire damper
- Optional with end position switches (-R-S)
- FDC25 fire dampers are equipped with R25 manual mechanism
- FDC40 fire dampers are equipped with R40 manual mechanism



	FDC25-R							FDC40-R						
Ød [mm]	100	125	160	200	250	315	355	400	450	500	560	630	710	800
Weight [kg]	3,8	4,2	4,7	5,4	6,3	7,7	11,9	13,5	15,4	17,5	20,4	23,6	27,7	33,7
K [mm]	120	128	140	155	176	204	221	242	265	289	317	351	389	433

*K - Dimension of the minimum installation opening

- ▼ [PRODUCT OVERVIEW](#)
- ▼ [DIMENSIONS](#)
- ▼ [INSTALLATIONS](#)
- ▼ [ACTUATORS](#)
- ▼ [ACCESSORIES](#)
- ▼ [REPLACEMENTS](#)
- ▼ [MAINTENANCE AND OPERATION](#)

DIMENSIONS

FIRE DAMPER - FDC

FDC25-R25 (up to d315)

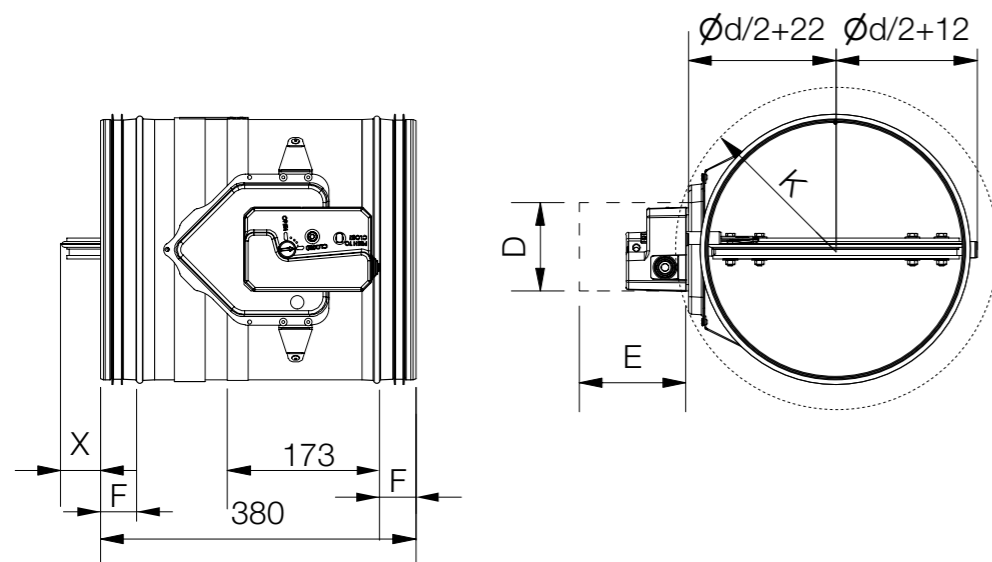

FDC40-R40 (d355 up to d800)

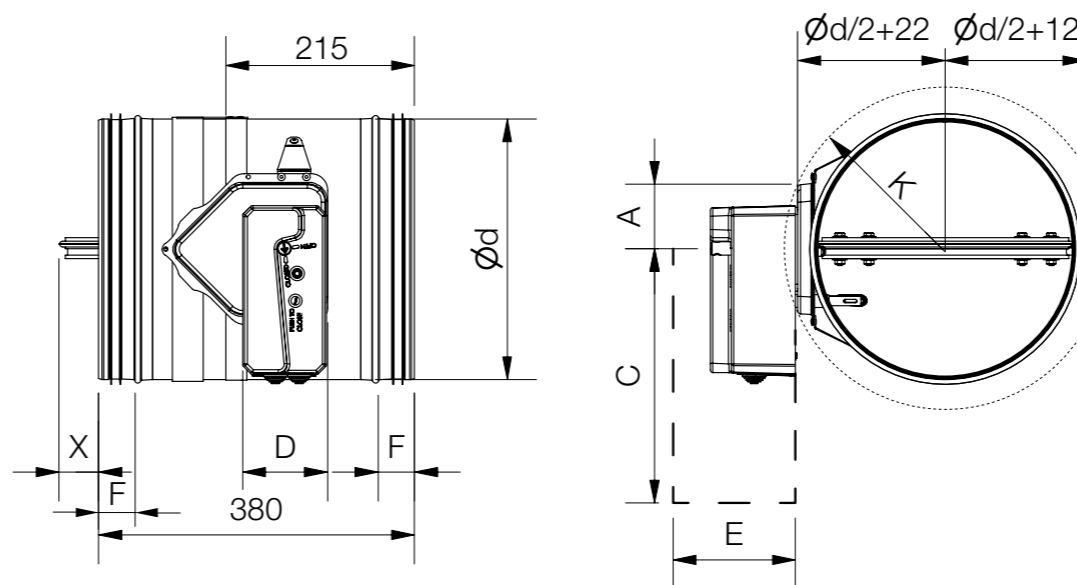

Product	A [mm]	C [mm]	D [mm]	E [mm]	F [mm]
FDC 25	55	150	105	150	42
FDC 40	55	200	105	200	42

Length of damper blade outside of casing (X dimension on front side):

$$X = (\frac{\phi d}{2}) - 110 \text{ [mm]}$$

*If the damper is larger than Ø540, use formula (Y dimension on back side):

$$Y = (\frac{\phi d}{2}) - 270 \text{ [mm]}$$

FDC25/FDC40 - EMS (solenoid actuator)

- Electromagnetic actuator with integrated limit switches and thermal fuse release mechanism (72 °C)
- Manual rearming
- Remote closing with electromagnetic actuator
- Manual closing possible
- EMS - solenoid actuator is constantly under power. Actuating mechanism is tripped when the power is interrupted, or thermal fuse is melted.



	FDC25-EMS							FDC40-EMS						
Ød [mm]	100	125	160	200	250	315	355	400	450	500	560	630	710	800
Weight [kg]	5,3	5,7	6,2	6,9	7,8	9,2	12,2	13,8	15,7	17,8	20,7	23,9	28	34
K [mm]	120	128	140	155	176	204	221	242	265	289	317	351	389	433

*K - Dimension of the minimum installation opening

- ▼ [PRODUCT OVERVIEW](#)
- ▼ [DIMENSIONS](#)
- ▼ [INSTALLATIONS](#)
- ▼ [ACTUATORS](#)
- ▼ [ACCESSORIES](#)
- ▼ [REPLACEMENTS](#)
- ▼ [MAINTENANCE AND OPERATION](#)

DIMENSIONS

FIRE DAMPER - FDC

Product	A [mm]	C [mm]	D [mm]	E [mm]	F [mm]
FDC 25	55	150	105	150	42
FDC 40	55	200	105	200	42

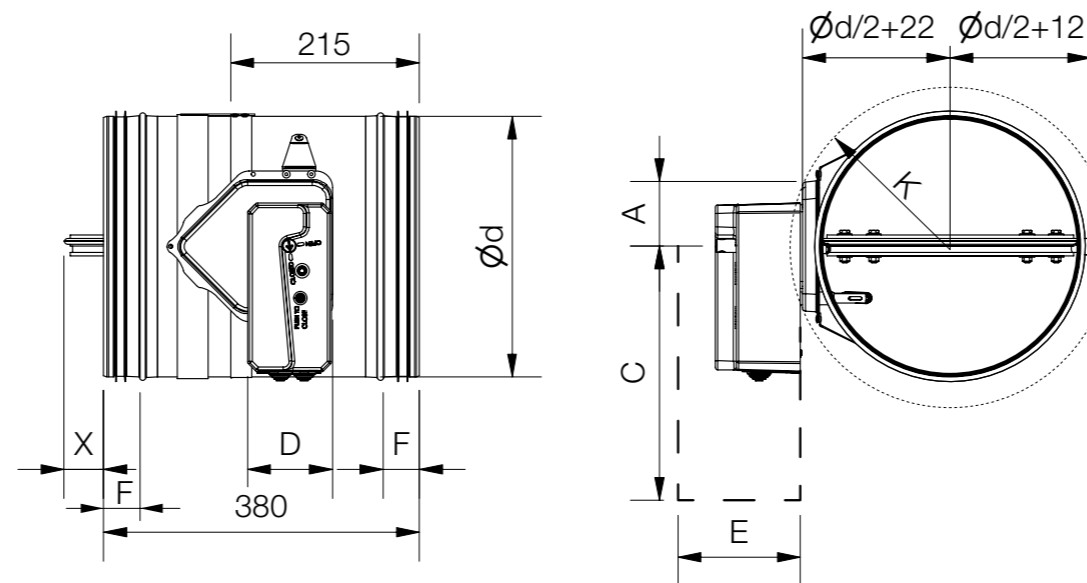

Length of damper blade outside of casing
(X dimension on front side):

$$X = (\text{Ød}/2) - 110 \text{ [mm]}$$

*If the damper is larger than Ø540, use formula
(Y dimension on back side):

$$Y = (\text{Ød}/2) - 270 \text{ [mm]}$$

FDC25/FDC40 - M (electric actuator)

- Thermoelectric release device (72 °C) with electric actuator and return spring
- Integrated end switches
- Fully automatic operation
- Optional 95 °C thermoelectric release device for warm air installations



	FDC25-M						FDC40-M							
Ød [mm]	100	125	160	200	250	315	355	400	450	500	560	630	710	800
Weight [kg]	4,5	4,9	5,4	6,1	7	8,4	11,7	13,3	15,2	17,3	20,2	23,4	29,1	35,1
Actuator type	BFL	BFL	BFL	BFL	BFL	BFL	BFN	BFN	BFN	BFN	BFN	BFN	BF	BF
K [mm]	120	128	140	155	176	204	221	242	265	289	317	351	389	433

*K - Dimension of the minimum installation opening

- ▼ [PRODUCT OVERVIEW](#)
- ▼ [DIMENSIONS](#)
- ▼ [INSTALLATIONS](#)
- ▼ [ACTUATORS](#)
- ▼ [ACCESSORIES](#)
- ▼ [REPLACEMENTS](#)
- ▼ [MAINTENANCE AND OPERATION](#)

DIMENSIONS

FIRE DAMPER - FDC

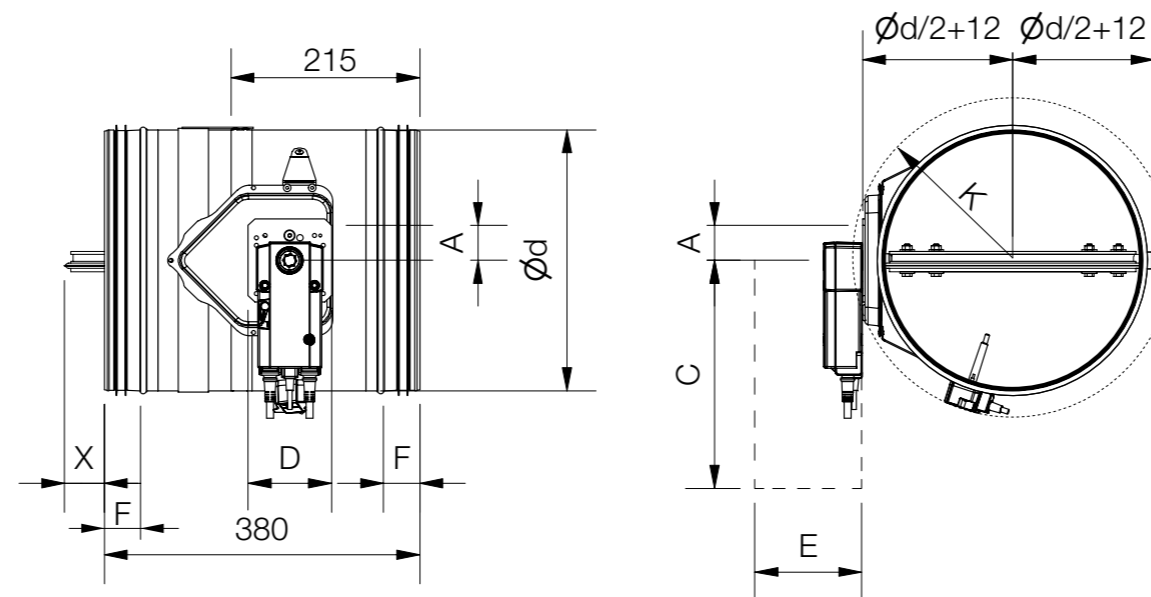

Product	A [mm]	C [mm]	D [mm]	E [mm]
BFL (M)	25	200	90	120
BFN (M)	25	225	100	120
BF (M)*	50	250	100	120

Product	F [mm]
FDC 25	42
FDC 40	42

Length of damper blade outside of casing
(X dimension on front side):

$$X = (\text{Ød}/2) - 110 \text{ [mm]}$$

*If the damper is larger than Ø540, use formula
(Y dimension on back side):

$$Y = (\text{Ød}/2) - 270 \text{ [mm]}$$

FDC25/FDC40 - EX (electric actuator)

- Thermoelectric release device (72 °C) with electric actuator and return spring
- Integrated end switches
- Fully automatic operation
- The EX version of the damper comes with:
 - 1) Safety temperature trigger Schischek ExPro-TT
 - 2) Electric actuator Schischek ExMax-5.10-BF
 - 3) Terminal box Schischek ExBox-BF

For more information see [page 43](#).

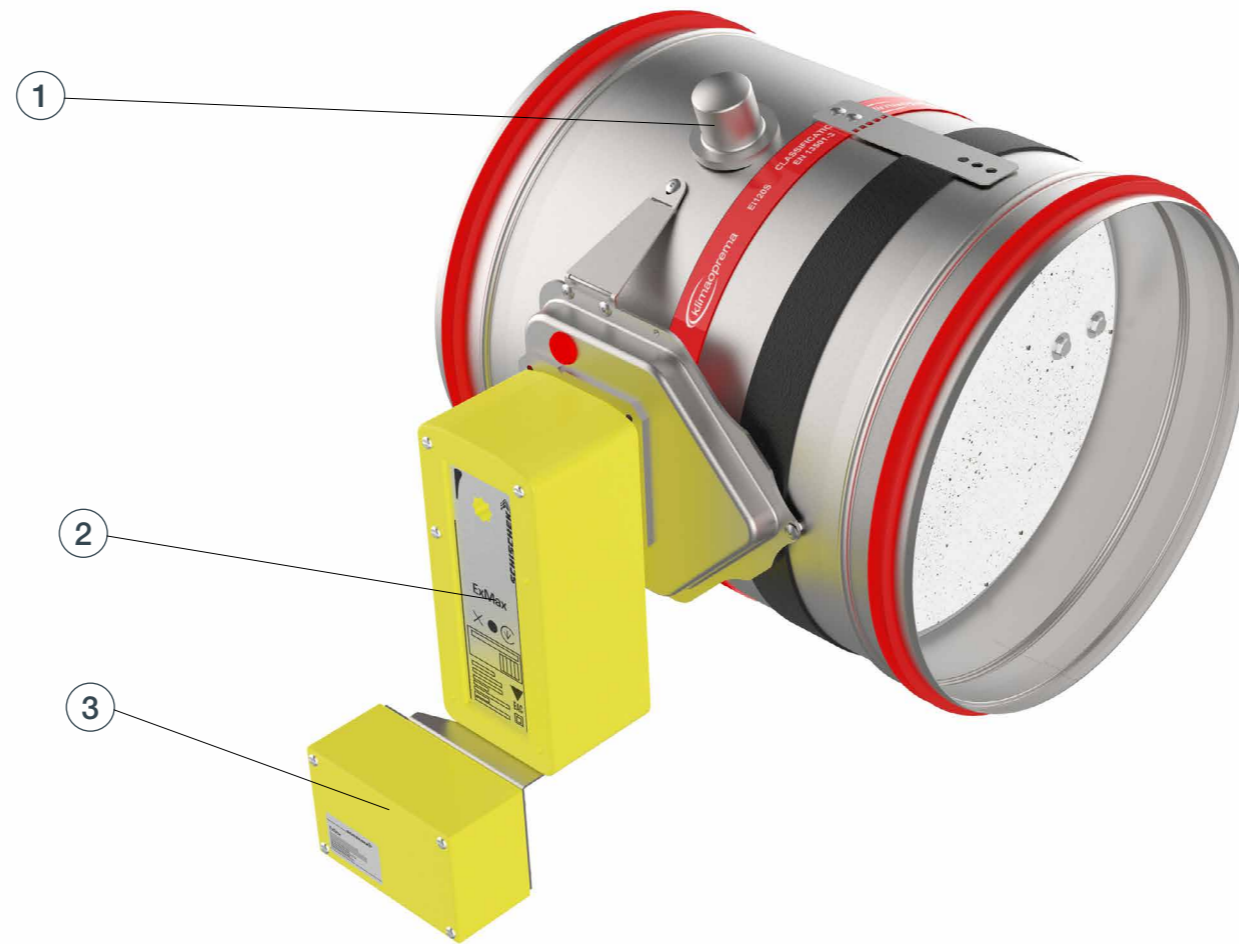

	FDC25-EX							FDC40-EX						
Ød [mm]	100	125	160	200	250	315	355	400	450	500	560	630	710	800
Weight [kg]	7,9	8,3	8,8	9,5	10,4	11,8	14,8	16,4	18,3	20,4	23,1	26,5	30,6	36,6
Actuator type	ATEX rated Schischek 24/230 V electric actuator+ExPro-TT+ExBox-BF													
K [mm]	120	128	140	155	176	204	221	242	265	289	317	351	389	433

*K - Dimension of the minimum installation opening

- ▼ [PRODUCT OVERVIEW](#)
- ▼ [DIMENSIONS](#)
- ▼ [INSTALLATIONS](#)
- ▼ [ACTUATORS](#)
- ▼ [ACCESSORIES](#)
- ▼ [REPLACEMENTS](#)
- ▼ [MAINTENANCE AND OPERATION](#)

DIMENSIONS

FIRE DAMPER - FDC

Ex classification of product:

Ex II 2G Ex h IIC T6 Gb

Ex II 2D Ex h IIIC T80°C Db

For more information about Ex classification, visit website: [ATEX classification!](#)

Type Examination Certificate Number: FIDI 21 ATEX D059. Equipment complies with the essential health and safety requirements relating to the design and construction of equipment intended to use in potentially explosive atmospheres given in annex VIII of the directive ATEX 2014/34/EU.

Please consult latest Declaration of conformity on our website:
[Actionair FDC](#)

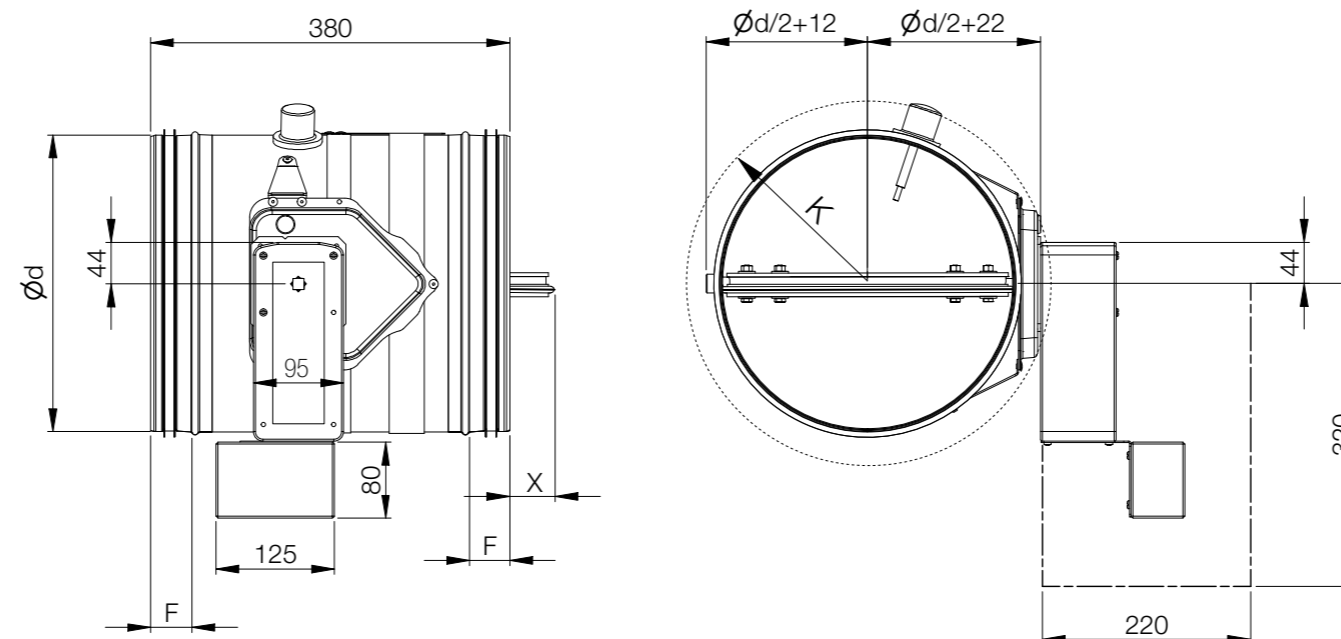

Model	F [mm]
FDC 25	42
FDC 40	42

Length of damper blade outside of casing (X dimension on front side):

$$X = (\text{Ød}/2) - 110 \text{ [mm]}$$

*If the damper is larger than Ø540, use formula (Y dimension on back side):

$$Y = (\text{Ød}/2) - 270 \text{ [mm]}$$

FDC25 - APP

Applique installation frame

- Applique kit is an installation subframe for quick and easy installation in rigid and flexible walls
- Made out of calcium silicate boards
- Quick wall mounting with screws
- Factory assembled to the fire damper



- ▼ [PRODUCT OVERVIEW](#)
- ▼ [DIMENSIONS](#)
- ▼ [INSTALLATIONS](#)
- ▼ [ACTUATORS](#)
- ▼ [ACCESSORIES](#)
- ▼ [REPLACEMENTS](#)
- ▼ [MAINTENANCE AND OPERATION](#)

	FDC25-APP-R						FDC25-APP-EMS						FDC25-APP-M					
Ød [mm]	100	125	160	200	250	315	100	125	160	200	250	315	100	125	160	200	250	315
Weight [kg]	6,2	6,7	7,8	8,5	10,1	12,3	7,7	8,2	9,3	10	11,6	13,8	6,9	7,4	8,5	9,2	10,8	13

DIMENSIONS

FIRE DAMPER - FDC

Damper diameter Ød[mm]	Applique frame diameter Ød + A [mm]
100	Ød + 105 mm
125 - 160	Ød + 95 mm
200 - 315	Ød + 80 mm

Product	F [mm]
FDC 25	42
FDC 40	42

FDC25-APP-R

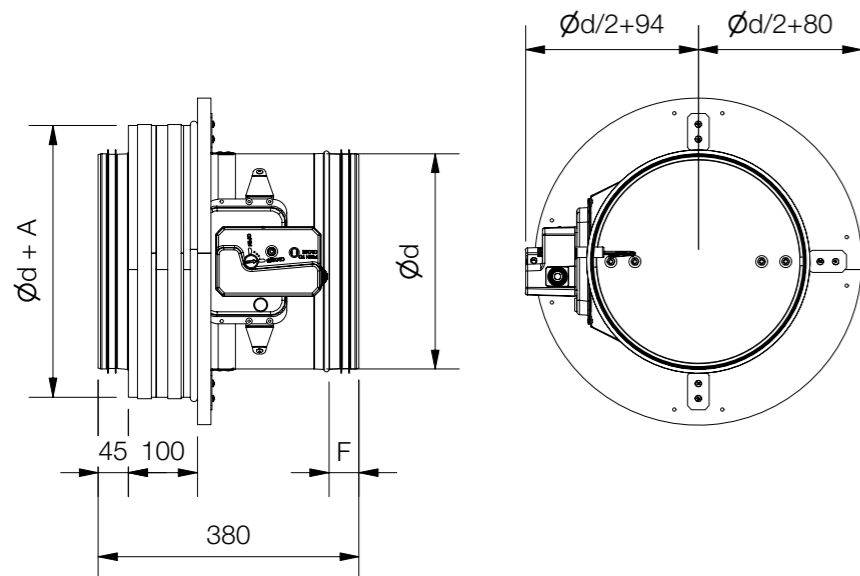

FDC25-APP-EMS

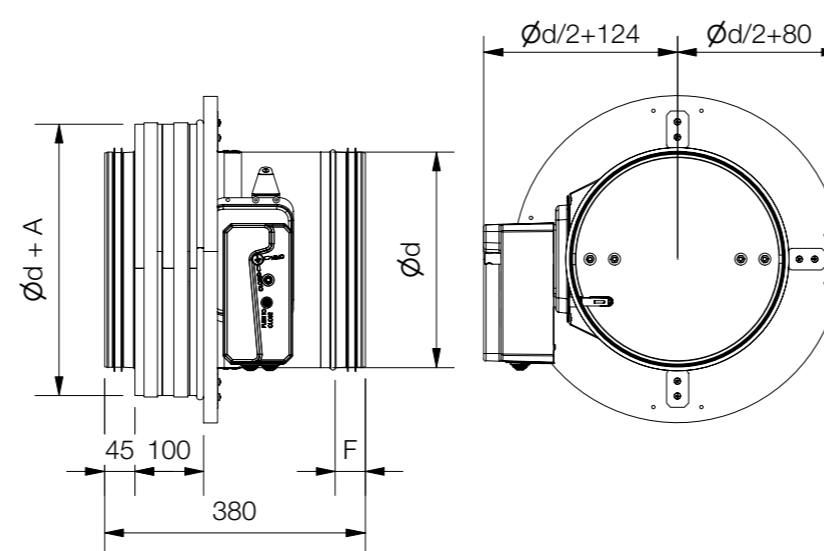

FDC25-APP-M

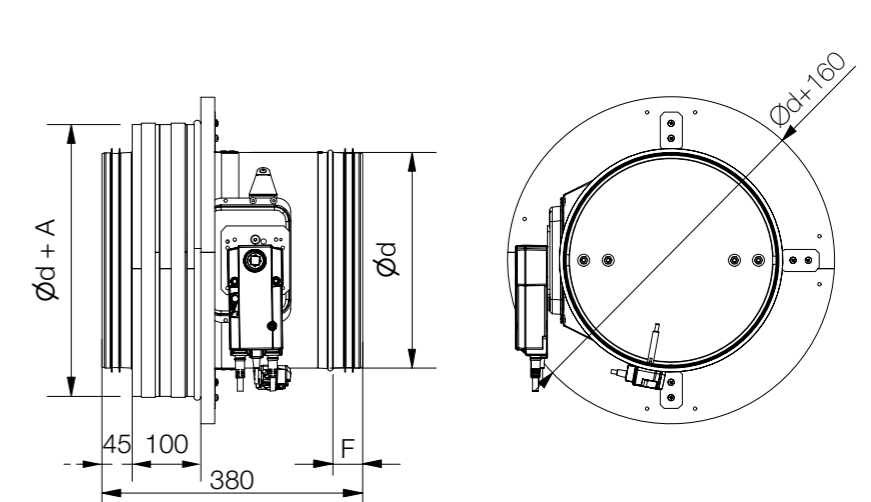

FDC25 - MF1

MF1 installation frame

- MF1 is an installation frame for quick and easy installation in rigid and flexible walls
- Made out of calcium silicate boards
- Quick wall mounting with screws
- Factory assembled to the fire damper



- ▼ [PRODUCT OVERVIEW](#)
- ▼ [DIMENSIONS](#)
- ▼ [INSTALLATIONS](#)
- ▼ [ACTUATORS](#)
- ▼ [ACCESSORIES](#)
- ▼ [REPLACEMENTS](#)
- ▼ [MAINTENANCE AND OPERATION](#)

	FDC25-MF1-R						FDC25-MF1-EMS						FDC25-MF1-M					
Ød [mm]	100	125	160	200	250	315	100	125	160	200	250	315	100	125	160	200	250	315
Weight [kg]	6,6	7,4	8,7	10,3	12,5	15,5	8,1	8,9	10,2	11,8	14	17	7,3	8,1	9,4	11	13,2	16,2

↑ DIMENSIONS

FIRE DAMPER - FDC

FDC25-MF1-R

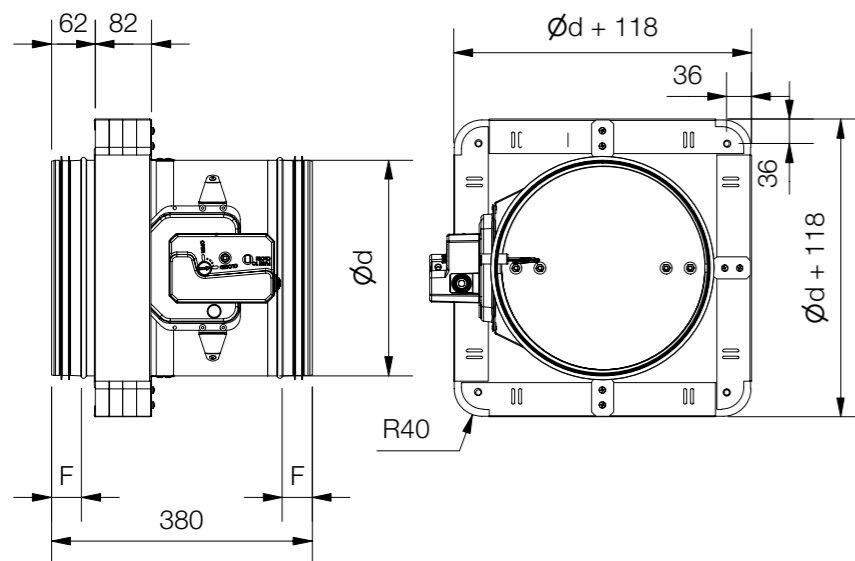

FDC25-MF1-EMS

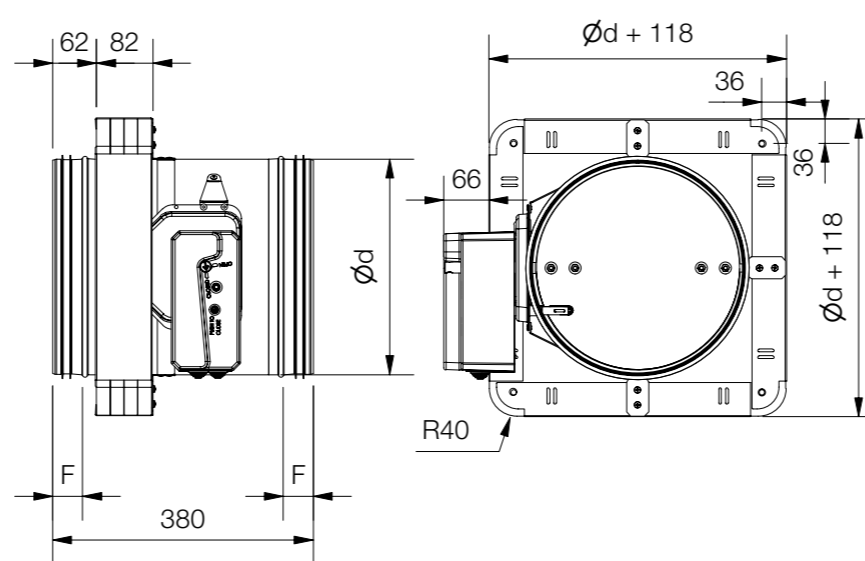

FDC25-MF1-M

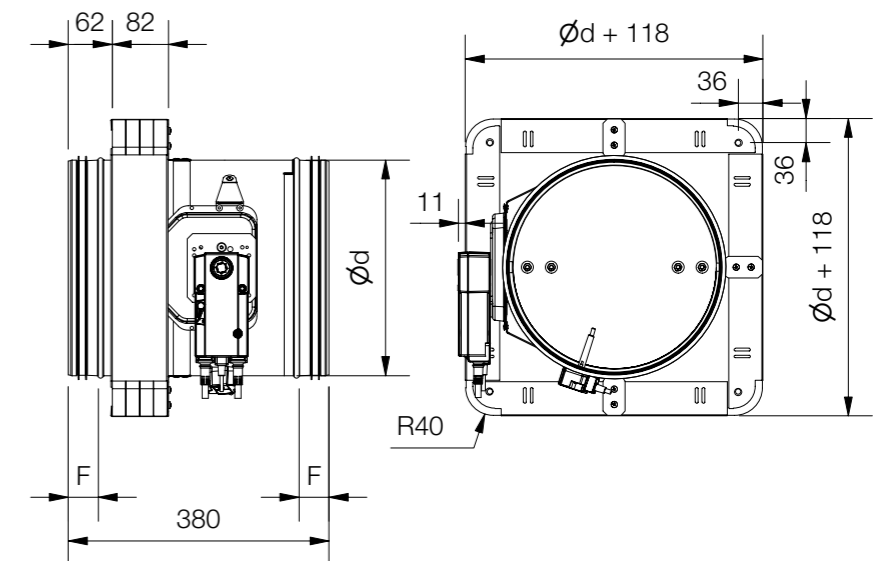

Product	F [mm]
FDC 25	42
FDC 40	42

FDC25 - MF2

MF2 installation frame

- MF2 is an installation frame for quick and easy installation in rigid, flexible and shaft walls
- Made out of calcium silicate boards
- Quick wall mounting with screws
- Factory assembled to the fire damper



- ▼ [PRODUCT OVERVIEW](#)
- ▼ [DIMENSIONS](#)
- ▼ [INSTALLATIONS](#)
- ▼ [ACTUATORS](#)
- ▼ [ACCESSORIES](#)
- ▼ [REPLACEMENTS](#)
- ▼ [MAINTENANCE AND OPERATION](#)

	FDC25-MF2-R						FDC25-MF2-EMS						FDC25-MF2-M					
Ød [mm]	100	125	160	200	250	315	100	125	160	200	250	315	100	125	160	200	250	315
Weight [kg]	7,1	8,1	9,6	11,4	13,8	17,2	8,6	9,6	11,1	12,9	15,3	18,7	7,8	8,8	10,3	12,1	14,5	17,9

↻ DIMENSIONS

FIRE DAMPER - FDC

FDC25-MF2-R

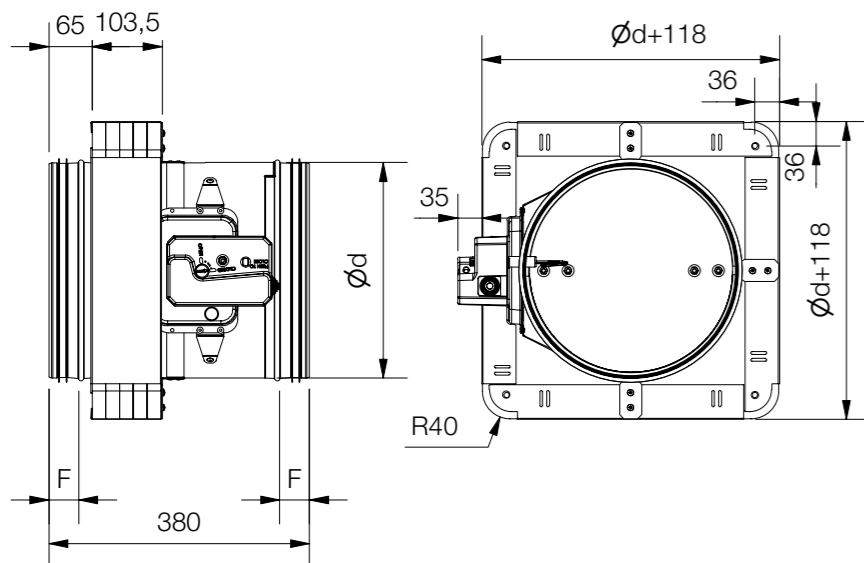

FDC25-MF2-EMS

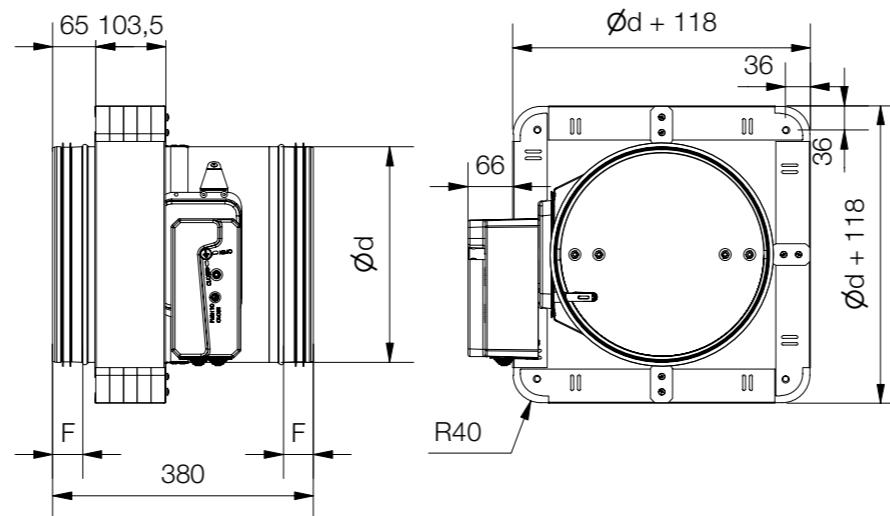

FDC25-MF2-M

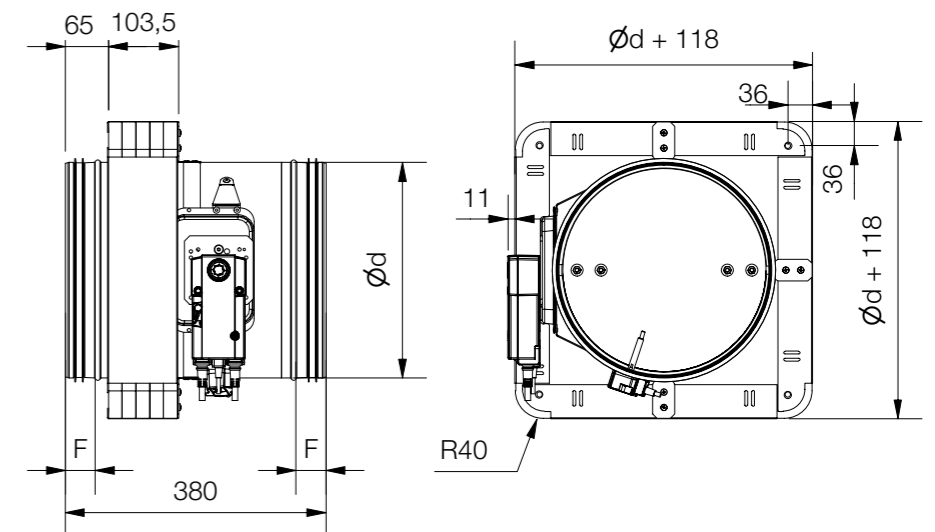

Product	F [mm]
FDC 25	42
FDC 40	42

FDC40 - MF2

MF2 installation frame

- MF2 is an installation frame for quick and easy installation in rigid, flexible and shaft walls
- Made out of calcium silicate boards
- Quick wall mounting with screws
- Factory assembled to the fire damper



- ▼ [PRODUCT OVERVIEW](#)
- ▼ [DIMENSIONS](#)
- ▼ [INSTALLATIONS](#)
- ▼ [ACTUATORS](#)
- ▼ [ACCESSORIES](#)
- ▼ [REPLACEMENTS](#)
- ▼ [MAINTENANCE AND OPERATION](#)

	FDC40-MF2-R							FDC40-MF2-EMS							FDC40-MF2-M						
Ød [mm]	355	400	450	500	560	630	800	355	400	450	500	560	630	800	355	400	450	500	560	630	800
Weight [kg]	22,8	25,9	29,6	33,6	39,1	45	62,8	23,1	26,2	29,9	33,9	39,5	45,3	63,1	22,6	25,7	29,4	33,4	39	44,8	64,2

↻ DIMENSIONS

FIRE DAMPER - FDC

FDC40-MF2-R / FDC40-MF2-EMS

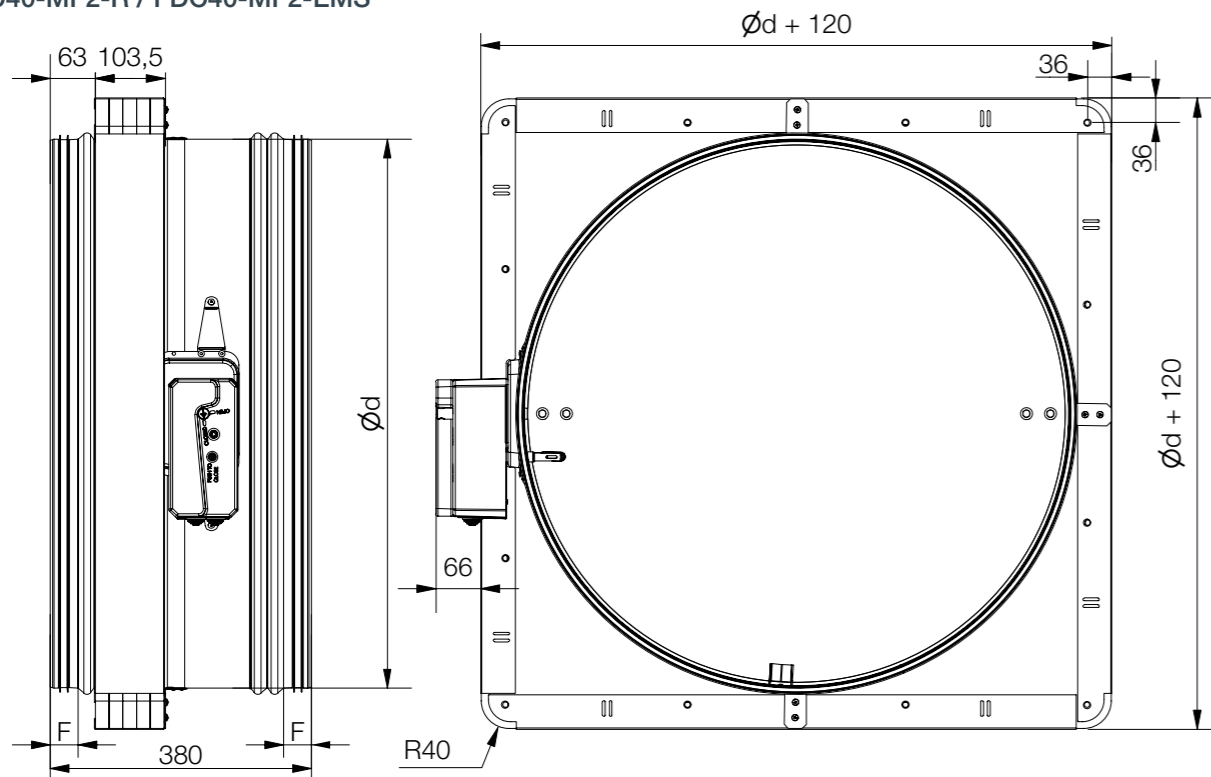

FDC40-MF2-M

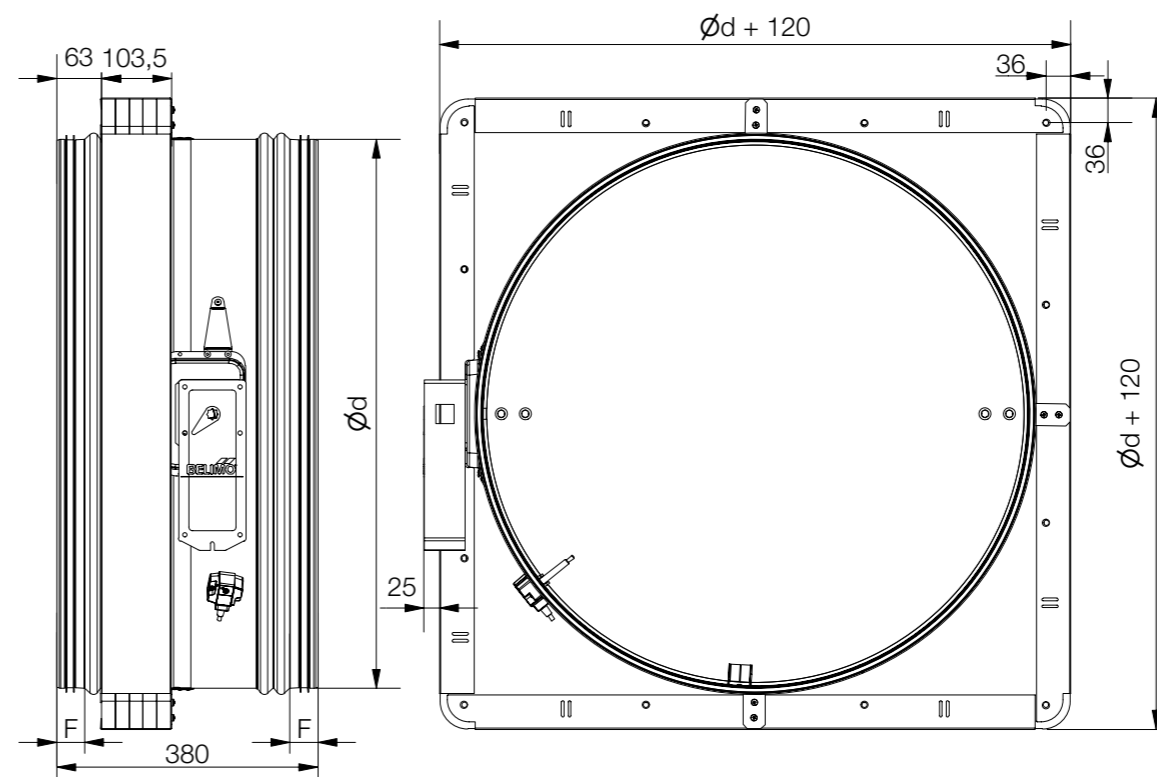

Product	F [mm]
FDC 25	42
FDC 40	42



INSTALLATION

The FDC25/FDC40 fire damper is always tested in standardized support frames (both in a rigid wall and in a flexible wall) in accordance with EN 1366-2: 2015 table 3/4/5. The results obtained are valid for all similar support frames which have a thickness and/or density and/or fire resistance similar or greater than the one on the test.

- ▼ [PRODUCT OVERVIEW](#)
- ▼ [DIMENSIONS](#)
- ▼ [INSTALLATIONS](#)
- ▼ [ACTUATORS](#)
- ▼ [ACCESSORIES](#)
- ▼ [REPLACEMENTS](#)
- ▼ [MAINTENANCE AND OPERATION](#)



FIRE DAMPER - FDC

The duct connected to the fire damper must be supported or hung in such a way that the damper does not carry its weight. The damper must not support any part of the surrounding construction or wall which could cause damage and consequent damper failure. It is recommended to connect the damper to a flexible connection on either end of the damper.

The damper driving mechanism can be placed on either side of the wall, however it needs to be placed so that it ensures an easy access during inspection.

- Mounting is possible with the blade axis in horizontal or in vertical position
- The installation must comply with the tests that were performed during certification
- Avoid any obstruction of the moving blade by the connected ducts
- The class of air-tightness is maintained in case the installation of the damper is made in accordance with the technical manual
- Operating temperature: 50 °C max
- For indoor use only

The gap in the installation opening between the fire damper and the wall/ceiling can be increased by up to 50%, or decreased to the smallest dimension where there is sufficient room for installation of the seal!

Recommended opening dimensions:

Damper size - Ød [mm]	Gap size - A (Recommended)	Opening size - Ød+2A (Recommended)
Ød ≤ 160	42,5 mm	Ød + 85 mm
200 ≤ Ød ≤ 315	37,5 mm	Ød + 75 mm
355 ≤ Ød ≤ 450	32,5 mm	Ød + 65 mm
Ød > 450	27,5 mm	Ød + 55 mm

Installation in both, vertical and horizontal axis of rotation of the dampers blade is acceptable (with the axis angle 0 - 360°).

The fire damper must be installed into a fire partition structure in such a way that the damper blade in its closed position is located inside this structure (except for Applique/ MF1/ MF2 kit installations).

To help you find the suspension plane, a bendable fixing bracket is provided on the damper body (the use of bendable fixing brackets is not required to meet the classification) and the red tape is placed on the casing to mark the location of the wall limit (distance from wall limit to the end of fire damper is 215 mm). This does not apply for Applique/MF1/MF2 kit installations. Check the operation of the fire damper before commencing the installation!

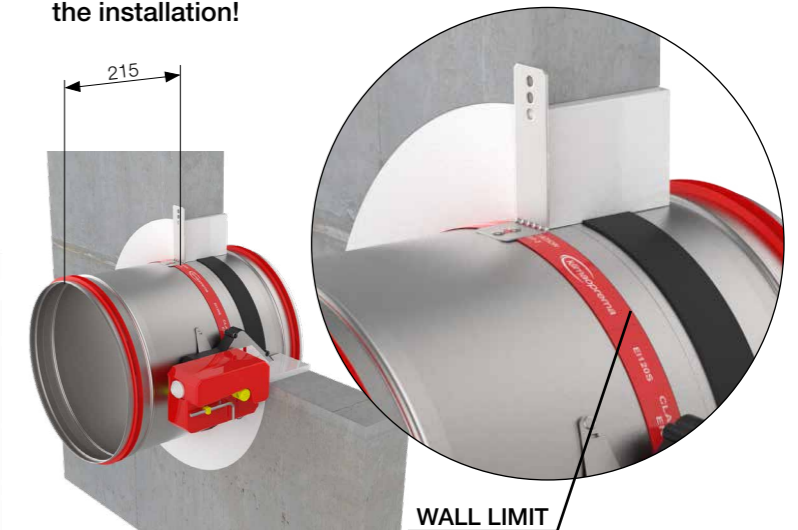
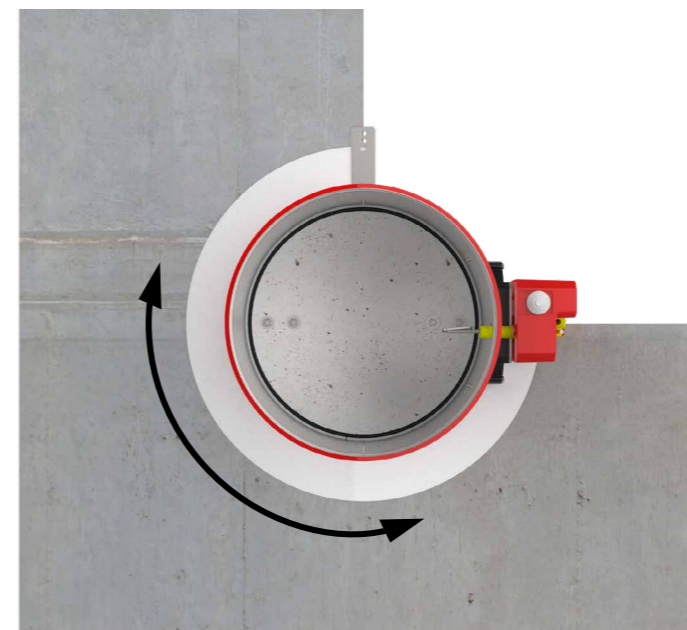

Standard actuator positions

FDC25 ELECTRIC ACTUATOR

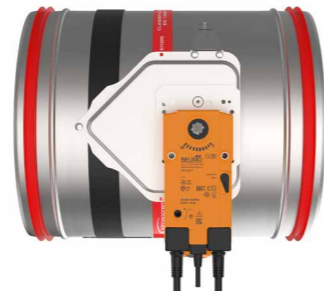

FDC-R25 MANUAL ACTUATOR

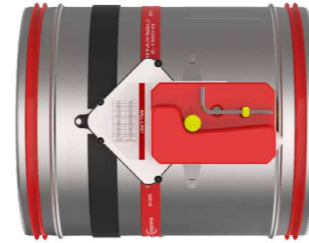

FDC40 ELECTRIC ACTUATOR

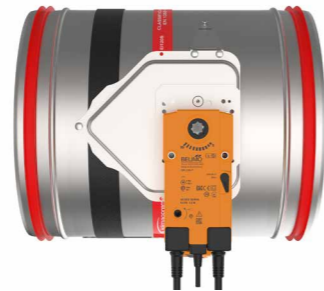

FDC-R40/EMS MANUAL ACTUATOR



FDC EX ACTUATOR



FDC-R40/EMS ACTUATOR
(Ød < 316)



-  [PRODUCT OVERVIEW](#)
-  [DIMENSIONS](#)
-  [INSTALLATIONS](#)
-  [ACTUATORS](#)
-  [ACCESSORIES](#)
-  [REPLACEMENTS](#)
-  [MAINTENANCE AND OPERATION](#)

FIRE DAMPER - FDC

Range	Supporting construction	Wall thickness	Supporting construction details	Type of installation	Classification	Tested underpressure	Details	Construction type	Sealing type
FDC25 d100-d315 mm / FDC40 d355-d800 mm	Rigid wall	≥ 100 mm	Aerated concrete (≥ 450kg/m³) Reinforced concrete (≥ 2200kg/m³)	Gypsum plaster / Mortar	EI 120 (ve i↔o)S	500Pa	▼		
				Mineral wool and cover boards	EI 90 (ve i↔o)S	500Pa	▼		
				Fire Batt/ Weichschott	EI 90 (ve i↔o)S	300Pa	▼		
	Flexible wall	≥ 70 mm	Gypsum blocks (≥ 995kg/m³)	Gypsum plaster / Mortar and cover boards	EI 120 (ve i↔o)S	500Pa	▼		
				Gypsum plaster / Mortar	A: FDC 25 EI 90 (ve i↔o)S A: FDC 40 EI 120 (ve i↔o)S B: EI 60 (ve i↔o)S	300Pa	▼		
		≥ 100 mm	A: Plasterboard type F (EN520), mineral wool up to 115 kg/m³ B: Plasterboard type A (EN520), mineral wool up to 60 kg/m³	Gypsum plaster / Mortar and cover boards	A: EI 120 (ve i↔o)S B: EI 60 (ve i↔o)S	500Pa	▼		
				Mineral wool and cover boards	A: EI 90 (ve i↔o)S B: EI 60 (ve i↔o)S	500Pa	▼		
				Fire Batt/ Weichschott	A: EI 90 (ve i↔o)S B: EI 60 (ve i↔o)S	300Pa	▼		
		≥ 75 mm	Plasterboard type F (EN520), mineral wool up to 115 kg/m³	Fire Batt/ Weichschott	EI 45 (ve i↔o)S	300Pa	▼		
		≥ 100 mm	Cross laminated timber (30+40+30 mm) (480 kg/m³) Mineral wool (≥ 23 kg/m³)	Fire Batt/ Weichschott	EI 90 (ve i↔o)S	300Pa	▼		
	Eurobond Firemaster Extra			FDC25:EI 60 (i↔o)S FDC40: EI 60 S/ E 90 S (i↔o)S	300Pa	▼			
	Rigid wall + Sliding ceiling	≥ 100 mm	Aerated concrete (≥ 450 kg/m³)	Gypsum plaster / Mortar + Mineral wool (70 kg/m³)	EI 120 (ve i↔o)S	300Pa	▼		
	Flexible wall + Sliding ceiling	≥ 100 mm	Plasterboard type F (EN520)	Gypsum plaster / Mortar and cover boards + Mineral wool (115 kg/m³)	EI 120 (ve i↔o)S	300Pa	▼		
	FDC25 d100-d315 mm FDC40 d355-d800 mm	Floor/ceiling	≥ 100 mm	Aerated concrete (≥ 450kg/m³) Reinforced concrete (≥ 2200kg/m³)	Gypsum plaster / Mortar	EI 120 (ho i↔o)S	500Pa	▼	
Fire Batt/ Weichschott					EI 90 (ho i↔o)S	300Pa	▼		

INSTALLATION

Check for more information about certificate installations in the declaration of performance:

- Aerated concrete (≥ 450 kg/m³) or reinforced concrete (≥ 2200 kg/m³) wall, more than 100 mm thick
- Gypsum blocks (≥ 995 kg/m³) wall, more than 70 mm thick
- Plasterboard wall, type F (EN520), Plasterboard wall, type A (EN520), more than 100 mm thick
- Shaft wall, steel frame construction
- Aerated concrete (≥ 450 kg/m³) or reinforced concrete (≥ 2200 kg/m³) ceiling / floor, more than 100 mm thick

FIRE DAMPER - FDC

- Gypsum plaster, mortar sealing or mortar and cover boards. Mortar EN 998-2 Classes M 2.5 to M 20 or equivalent mortars that meet the requirements of the above standards, gypsum mortar or concrete.
- Sealing with mineral wool and cover boards
- Sealing with mineral wool and fireproof coating - FireBatt / Weichschott
- Applique kit installation
- MF1/MF2 kit installation
- Remote from wall installation

Range	Supporting construction	Wall thickness	Supporting construction details	Type of installation	Classification	Tested underpressure	Details	Construction type	Sealing type
APP INSTALLATION FRAME FDC25 d100-d315 mm	Rigid wall	≥ 100 mm	Aerated concrete (≥ 450kg/m ³) Reinforced concrete (≥ 2200kg/m ³)	APPLIQUE (installation frame)	EI 90 (ve i↔o)S	500Pa	▼		
		≥ 70 mm	Gypsum blocks (≥ 995kg/m ³)	APPLIQUE (installation frame)	EI 90 (ve i↔o)S	500Pa	▼		
	Flexible wall	≥ 100 mm	Plasterboard type F (EN520) A (EN520)	APPLIQUE (installation frame)	EI 90 (ve i↔o)S EI 60 (ve i↔o)S	500Pa	▼		
MF1/ MF2 INSTALLATION FRAME FDC25 MF1 d100-d315 mm FDC25/FDC40 MF2 d355-d800 mm	Rigid wall	≥ 100 mm	Aerated concrete (≥ 450kg/m ³) Reinforced concrete (≥ 2200kg/m ³)	MF1 (installation frame)	FDC25:EI 60 (ve i↔o)S	500Pa	▼		
				MF2 (installation frame)	EI 90 (ve i↔o)S	FDC25: 300Pa FDC40: 500Pa			
	Rigid wall	≥ 70 mm	Gypsum blocks (≥ 995kg/m ³)	MF1 (installation frame)	FDC25:EI 60 (ve i↔o)S	500Pa	▼		
				MF2 (installation frame)	EI 90 (ve i↔o)S				
	Flexible wall	≥ 100 mm	Plasterboard A:type A (EN520) B:type F (EN520)	MF1 (installation frame)	A:FDC25:EI 60 (ve i↔o)S B:FDC25:EI 60 (ve i↔o)S	500Pa	▼		
				MF2 (installation frame)	A:EI 60 (ve i↔o)S B:EI 90 (ve i↔o)S				
Floor/ceiling	≥ 100 mm	Aerated concrete (≥ 450kg/m ³) Reinforced concrete (≥ 2200kg/m ³)	MF1 (installation frame)	FDC25:EI120 (ho i↔o)S	300Pa	▼			
			MF2 (installation frame)	FDC40:EI 90 (ho i↔o)S					
MF2 INSTALLATION FRAME FDC25 MF2 d100-d315 mm FDC40 MF2 d355-d800 mm	Flexible wall	≥ 75 mm	Shaft wall (steel frame)	MF2 (installation frame)	EI 60 (ve i↔o)S	300Pa	▼		
		≥ 90 mm			EI 90 (ve i↔o)S				
ISOVER FDC25 d100-d315 mm FDC40 d355-d630 mm	Flexible wall	≥ 100 mm	Plasterboard type F (EN520)	REMOTE FROM WALL (Isover)	EI 60 (ve i↔o)S	300Pa	▼		
	Rigid wall		Aerated concrete (≥ 450kg/m ³) Reinforced concrete (≥ 2200kg/m ³)						

INSTALLATION

Check for more information about certificate installations in the declaration of performance:

- Aerated concrete (≥ 450 kg/m³) or reinforced concrete (≥ 2200 kg/m³) wall, more than 100 mm thick
- Gypsum blocks (≥ 995 kg/m³) wall, more than 70 mm thick
- Plasterboard wall, type F (EN520), Plasterboard wall, type A (EN520), more than 100 mm thick
- Shaft wall, steel frame construction
- Aerated concrete (≥ 450 kg/m³) or reinforced concrete (≥ 2200 kg/m³) ceiling / floor, more than 100 mm thick

FIRE DAMPER - FDC

- Gypsum plaster, mortar sealing or mortar and cover boards
- Sealing with mineral wool and cover boards
- Sealing with mineral wool and fireproof coating - FireBatt / Weichschott
- Applique kit installation
- MF1/MF2 kit installation
- Remote from wall installation

Rigid wall installation (mortar sealing)

The wall is composed of concrete blocks (minimum density of 450 kg/m³) or reinforced concrete (minimum density of 2200 kg/m³) and with a minimum thickness of 100 mm. Installation material is gypsum plaster or mortar (C).



INSTALLATION

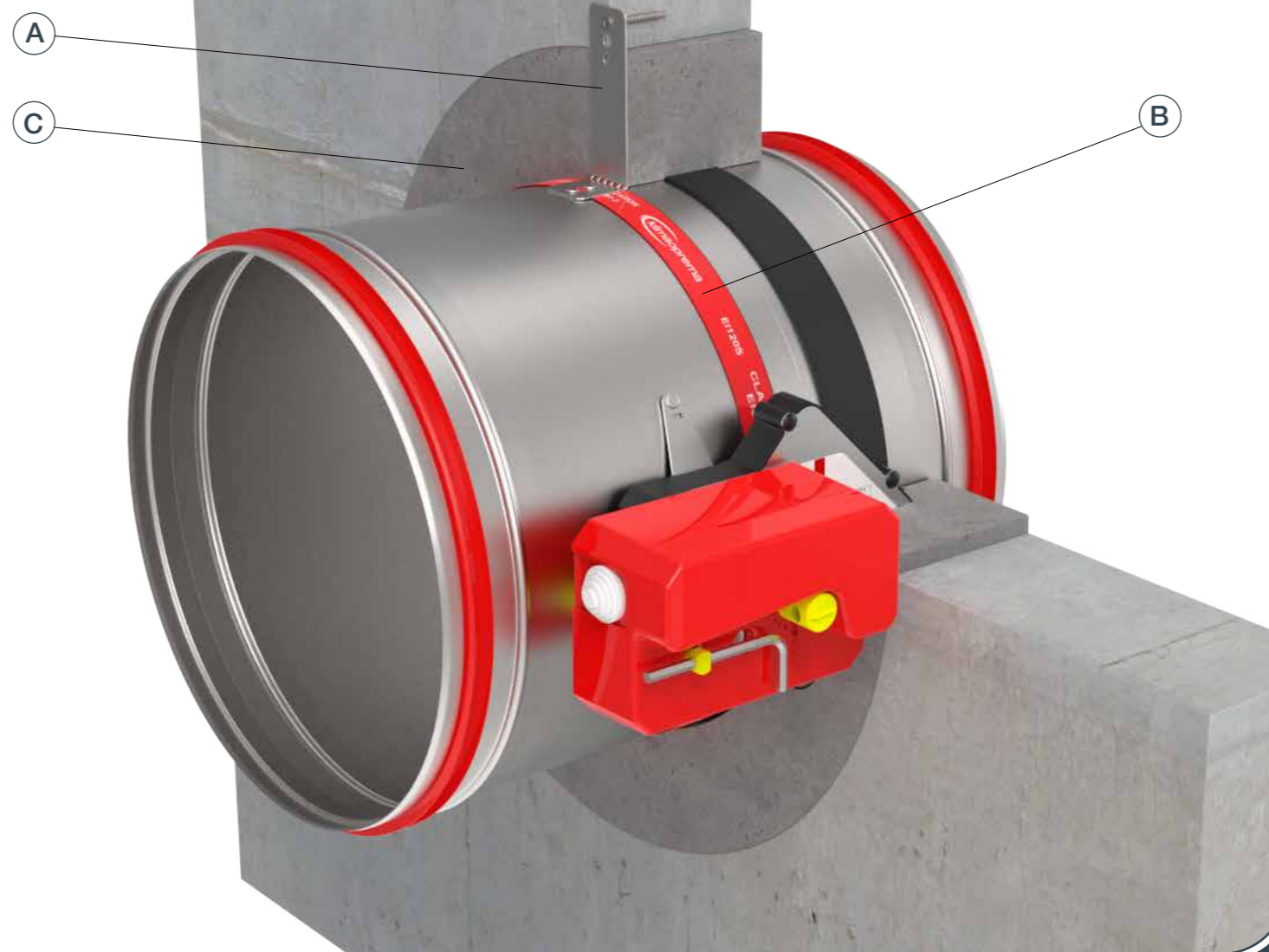

- ▼ [PRODUCT OVERVIEW](#)
- ▼ [DIMENSIONS](#)
- ▼ [INSTALLATIONS](#)
- ▼ [ACTUATORS](#)
- ▼ [ACCESSORIES](#)
- ▼ [REPLACEMENTS](#)
- ▼ [MAINTENANCE AND OPERATION](#)

Possible damper orientations



FIRE DAMPER - FDC

1. Create an opening in the wall (minimal dimensions on [pg.14](#)). Bend the fixing bracket (A) 90°. Place the damper in the opening up to the wall limit mark (B) on the damper.

Damper blade must be closed during the installation!

2. Fix the damper to the wall using screws. Bracket screw hole is 6 mm in diameter.

3. Fill the space between the damper and the wall with gypsum plaster or mortar (C).

*Multiple fire dampers can be installed next to each other or ceiling/wall with the minimal distance of 30 mm between them, [see page 45](#).

Test the operation of the damper blade!

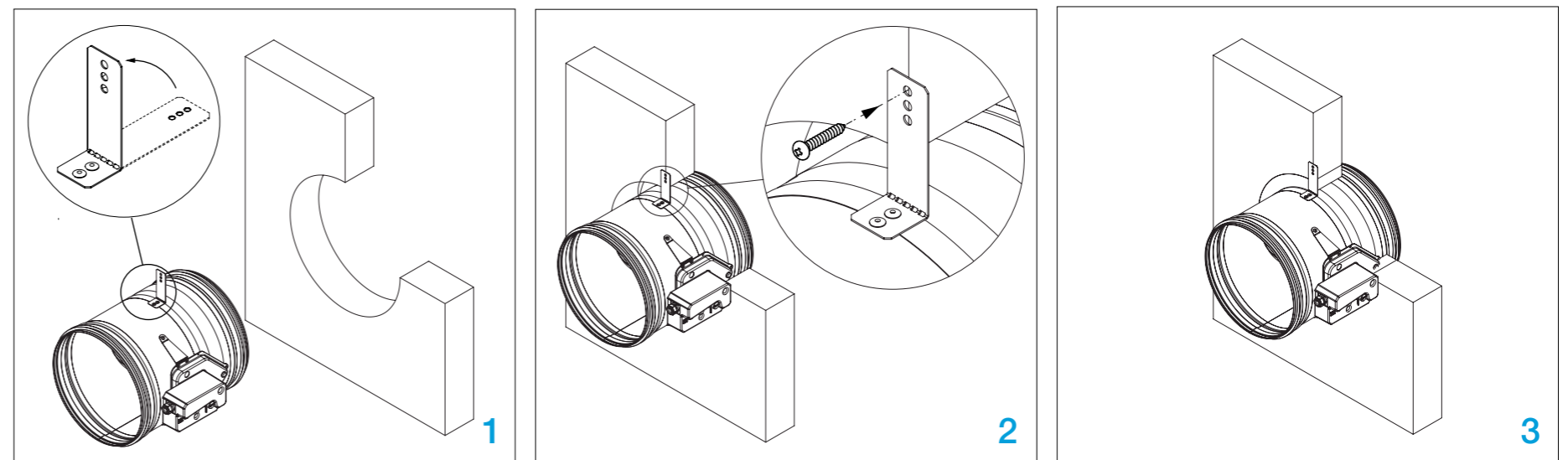

Rigid wall installation (mineral wool sealing)

The wall is composed of concrete blocks (minimum density of 450 kg/m³) or reinforced concrete (minimum density of 2200 kg/m³) and with a minimum thickness of 100 mm. Installation material is mineral wool (C) (minimum density of 100 kg/m³) covered with plasterboard cover boards (D).

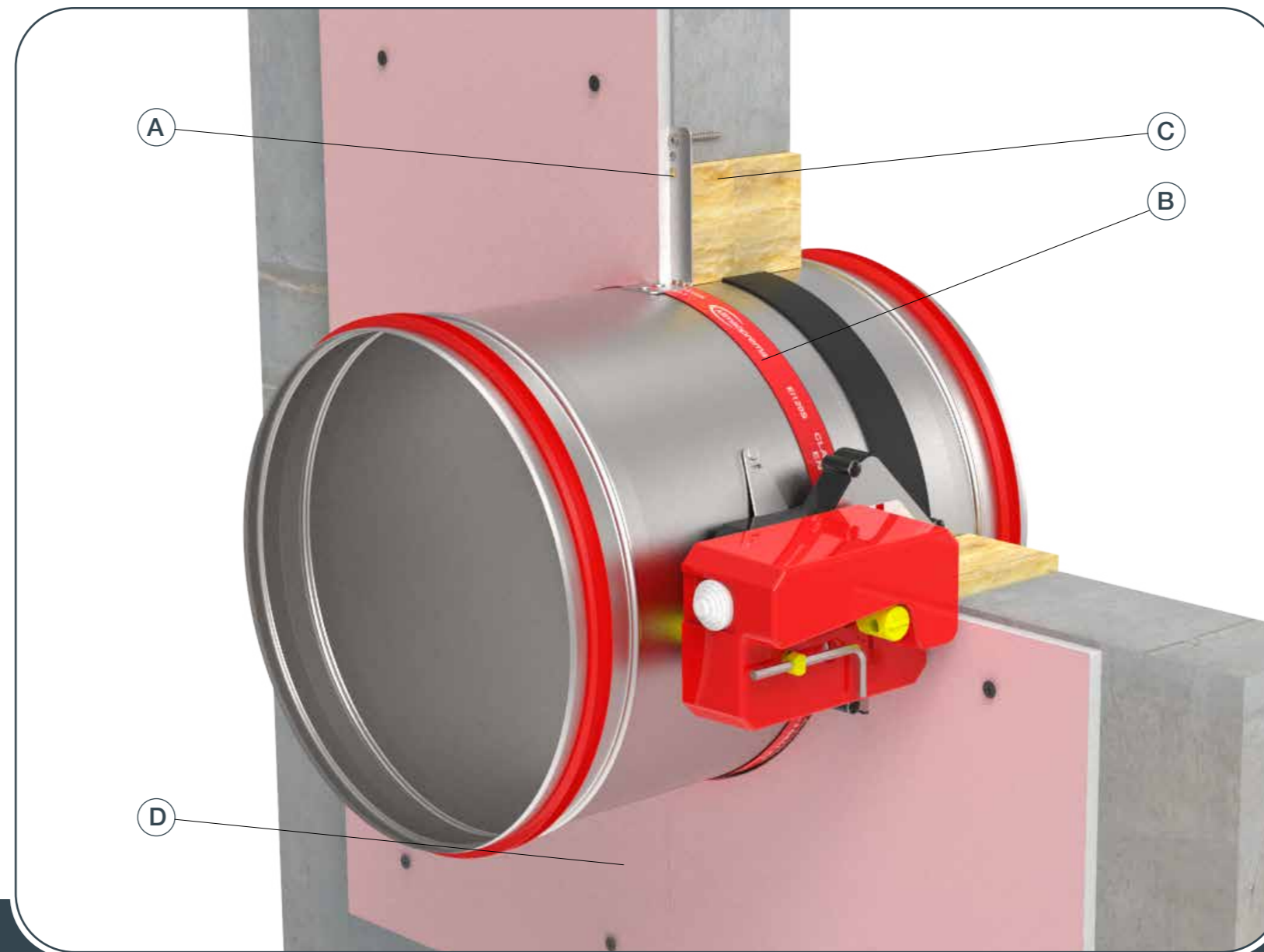

- ▼ [PRODUCT OVERVIEW](#)
- ▼ [DIMENSIONS](#)
- ▼ [INSTALLATIONS](#)
- ▼ [ACTUATORS](#)
- ▼ [ACCESSORIES](#)
- ▼ [REPLACEMENTS](#)
- ▼ [MAINTENANCE AND OPERATION](#)

Possible damper orientations



INSTALLATION

1. Create an opening in the wall (Ød + 80 mm) x (Ød + 80 mm). Bend the fixing bracket (A) 90°. Place the damper in the opening up to the wall limit mark (B) on the damper.

Damper blade must be closed during the installation!

2. Fix the damper to the wall using screws. Bracket screw hole is 6 mm in diameter.

3. Fill the space between the damper and the wall with mineral wool (C). Cover the mineral wool with GKF gypsum boards (D) (12,5 mm thick), fix them with screws.

*Multiple fire dampers can be installed next to each other or ceiling/wall with the minimal distance of 30 mm between them, [see page 45](#).

Test the operation of the damper blade!

FD-A-CSP-BxH
For more details see [pg.51](#)

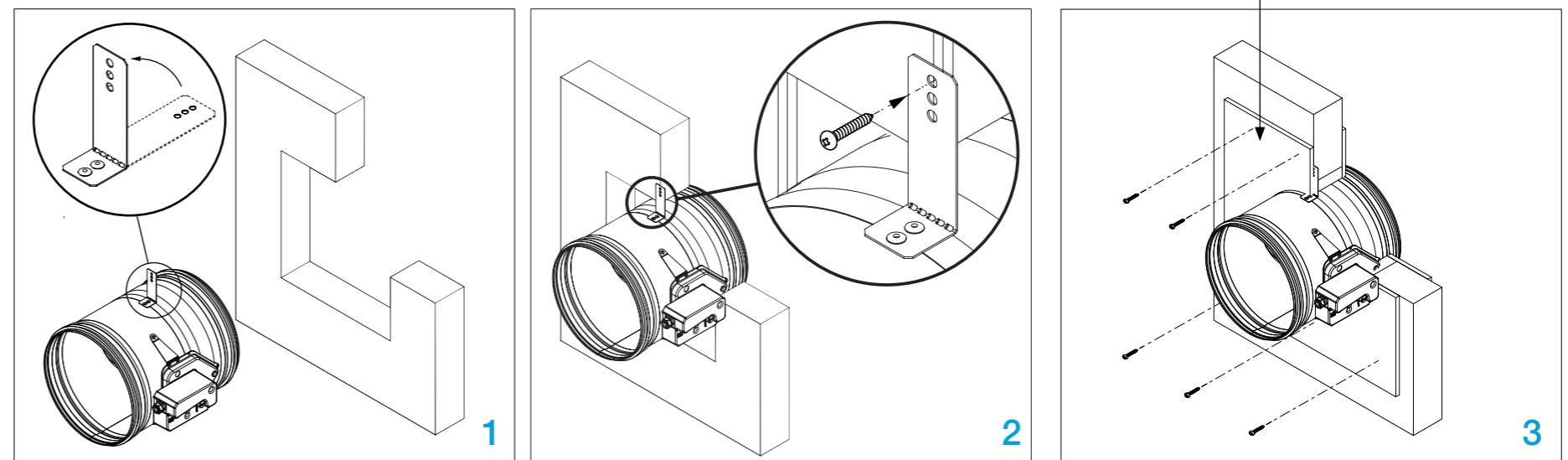

Rigid wall installation (Fire Batt/ Weichschott)

The wall is composed of concrete blocks (minimum density of 450 kg/m³) or reinforced concrete (minimum density of 2200 kg/m³) and with a minimum thickness of 100 mm.
Installation material: Mineral wool (C) (minimum density of 140 kg/m³), fire protection coating (D).

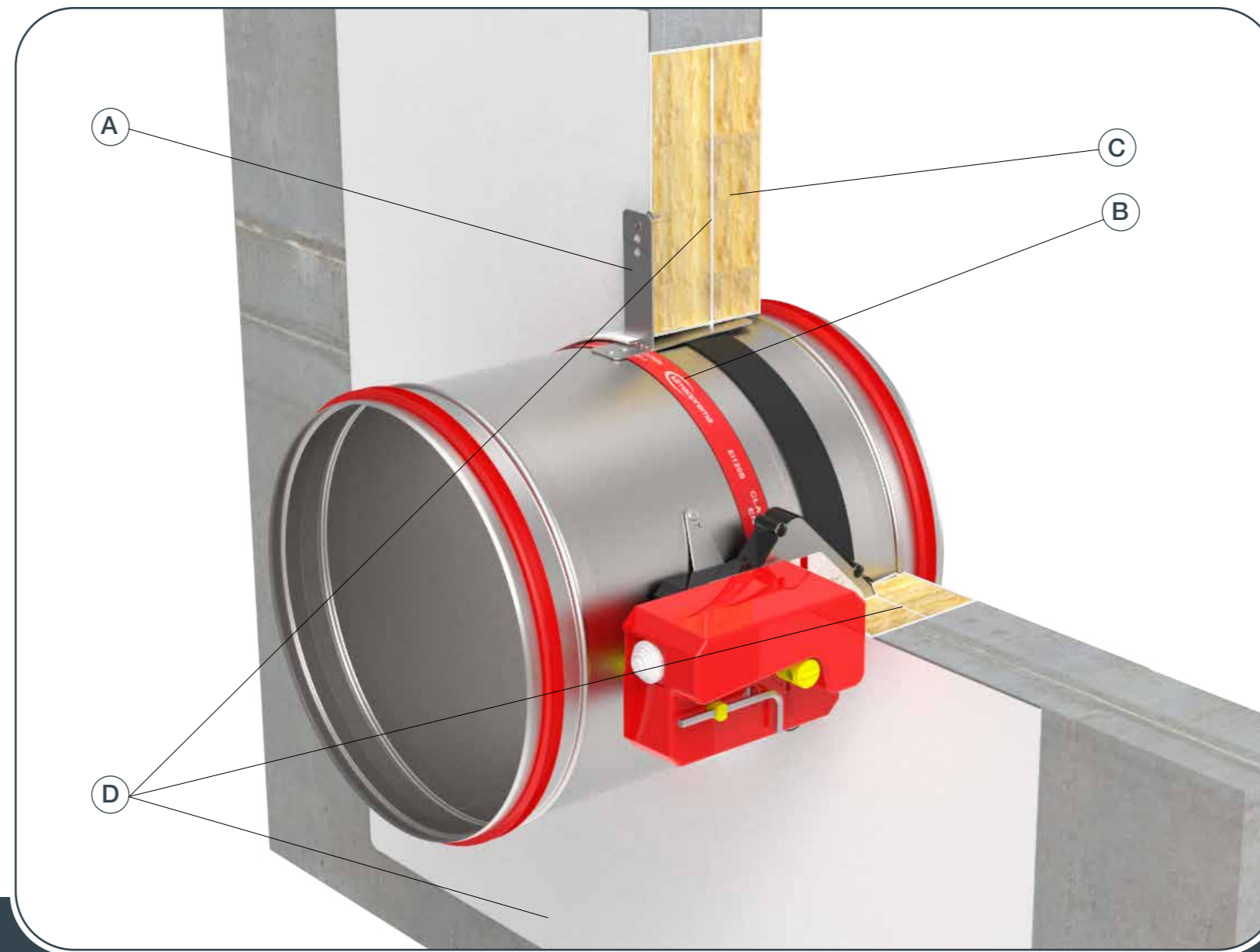

- ▼ [PRODUCT OVERVIEW](#)
- ▼ [DIMENSIONS](#)
- ▼ [INSTALLATIONS](#)
- ▼ [ACTUATORS](#)
- ▼ [ACCESSORIES](#)
- ▼ [REPLACEMENTS](#)
- ▼ [MAINTENANCE AND OPERATION](#)

Possible damper orientations



FIRE DAMPER - FDC

1. Create an opening in the wall (Ød + 80...300 mm) x (Ød + 80...300 mm). Bend the fixing bracket (A) 90°. Place the damper in the opening up to the wall limit mark (B) on the damper.

Damper blade must be closed during the installation!

2. Close the space between casing and wall with two layers of mineral wool (C) (50 mm thick, coated on one side).

3. Seal the connections of mineral wool with intumescent fire resistant sealant (D). Mineral wool and damper casing must be coated with 2 mm thick fire protection coating. Damper casing should be coated up to profile protrusions.

*Multiple fire dampers can be installed next to each other or ceiling/wall with the minimal distance of 30 mm between them, [see page 45](#).

Test the operation of the damper blade!

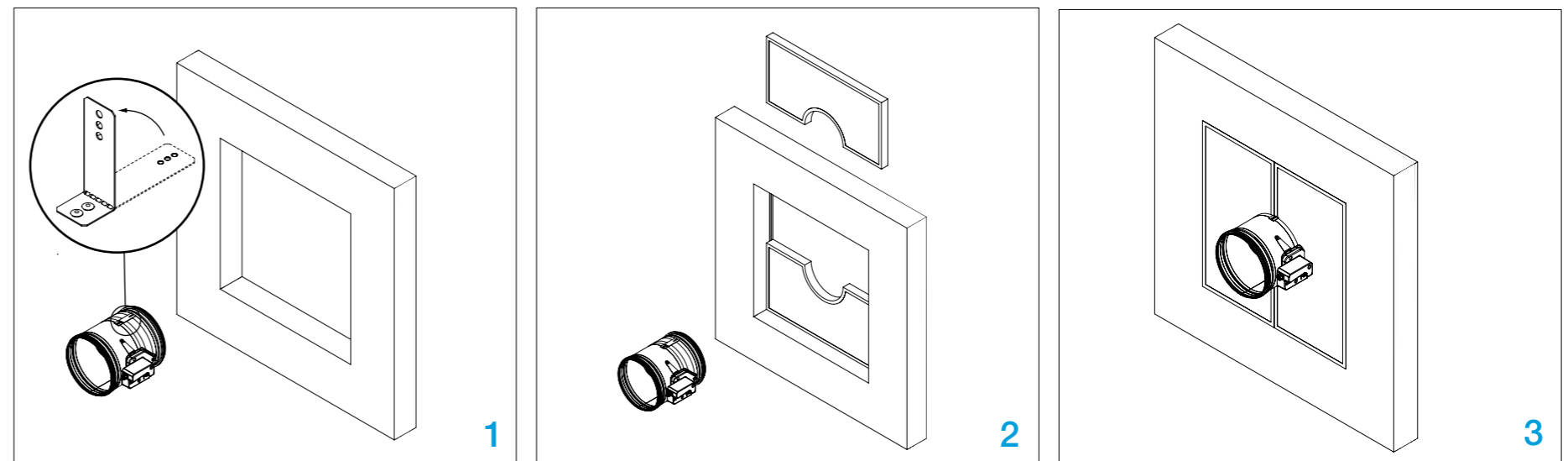

Gypsum blocks wall installation (mortar sealing)

The wall is composed of gypsum blocks (minimum density of 995 kg/m³), with minimum thickness of 70 mm. Installation material is gypsum plaster or mortar (C) covered with plasterboard cover boards (D).



INSTALLATION

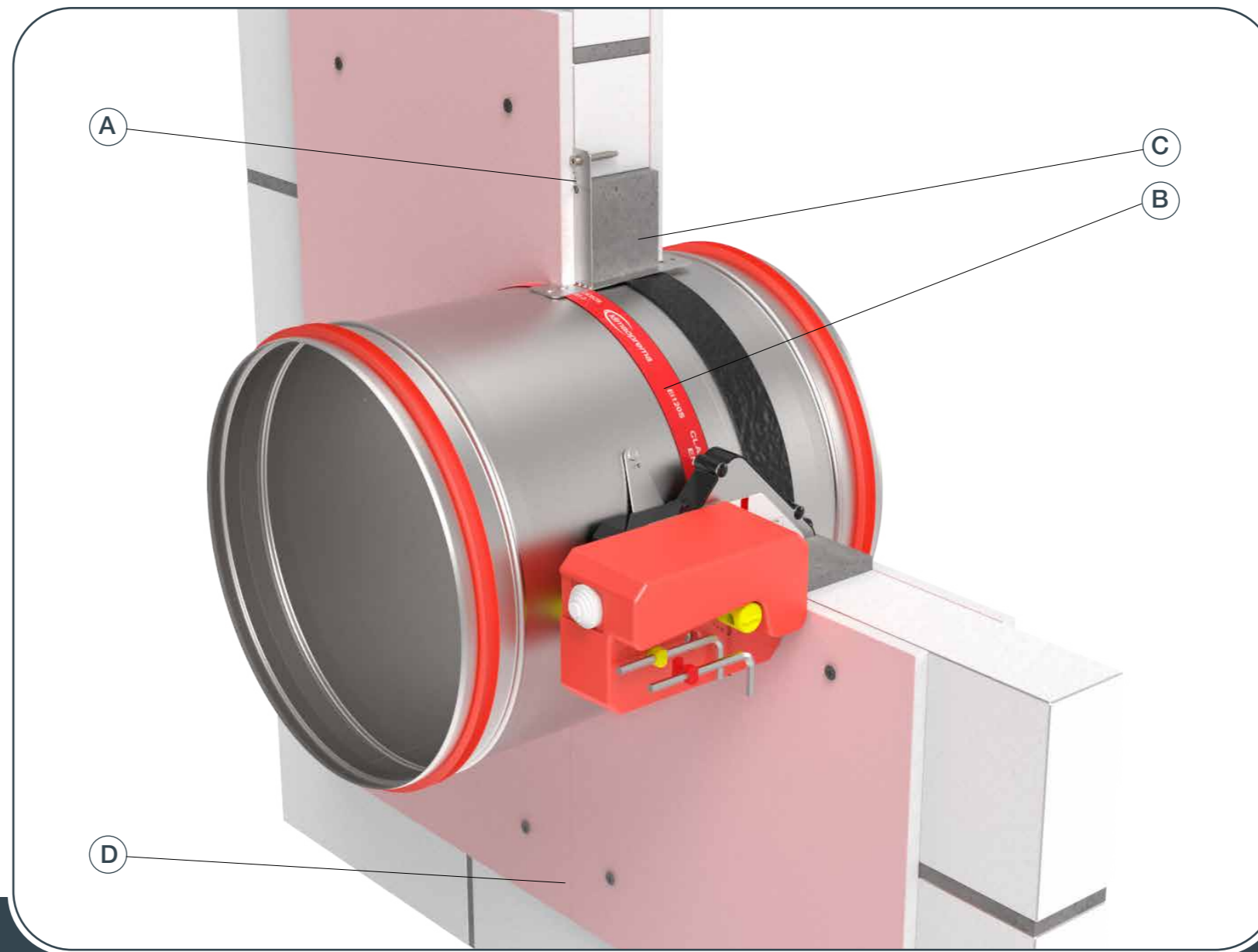

- ▼ [PRODUCT OVERVIEW](#)
- ▼ [DIMENSIONS](#)
- ▼ [INSTALLATIONS](#)
- ▼ [ACTUATORS](#)
- ▼ [ACCESSORIES](#)
- ▼ [REPLACEMENTS](#)
- ▼ [MAINTENANCE AND OPERATION](#)

Possible damper orientations



FIRE DAMPER - FDC

1. Create an opening in the wall (minimal dimensions on [pg.14](#)). Cover the hole with GKF gypsum boards (D) (12,5 mm thick) on the one side, fix them with self-tapping screws Ø3,5x45 mm.

2. Bend the fixing bracket (A) 90°. Place the damper in the opening up to the wall limit mark (B) on the damper. Fix the damper to the wall using screws (bracket screw hole is 6 mm in diameter). **Damper blade must be closed during the installation!**

3. Fill the space between the damper and the wall with mortar (C). Cover the mortar with GKF gypsum boards (D) (12,5 mm thick), fix them with self-tapping screws Ø3,5x45 mm.

*Multiple fire dampers can be installed next to each other or ceiling/wall with the minimal distance of 30 mm between them, [see page 45](#).

Test the operation of the damper blade!

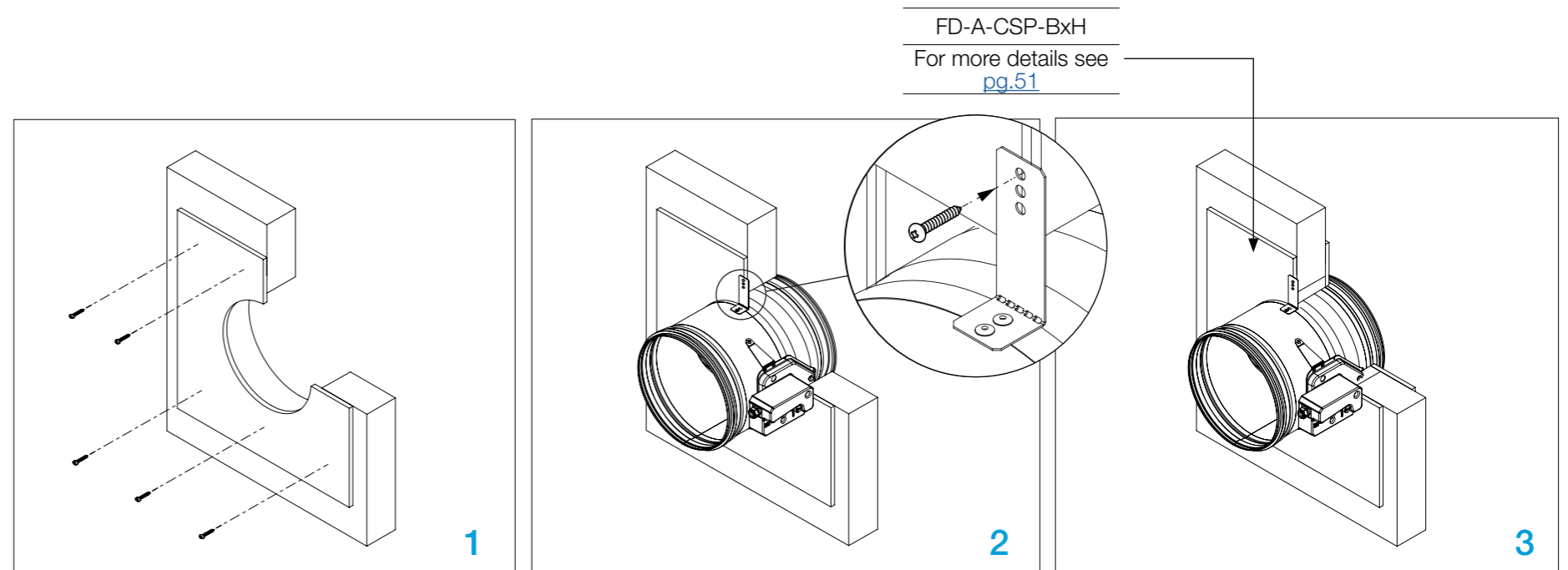

Flexible wall installation (mortar sealing)

The wall is composed of 2x2 plasterboard boards, 12,5 mm thick, installed on a steel frame construction. Installation material: gypsum plaster or mortar (C) covered with type F(EI 120) or type A(EI 60) cover boards (D). The minimum thickness of the wall is 100 mm.

EI 120 (ve i↔o)S

The wall is made out of type F (EN520) gypsum plaster boards. To fulfill the classification it is **NOT** mandatory to use the mineral wool inside the wall (mineral wool (E) with density up to 100 kg/m³ can be used).

EI 60 (ve i↔o)S

The wall is made out of type A (EN520) gypsum plaster boards. To fulfill the classification it is **NOT** mandatory to use the mineral wool inside the wall (mineral wool (E) with density up to 60 kg/m³ can be used).



(mineral wool (E) with density up to 60 kg/m³ can be used).

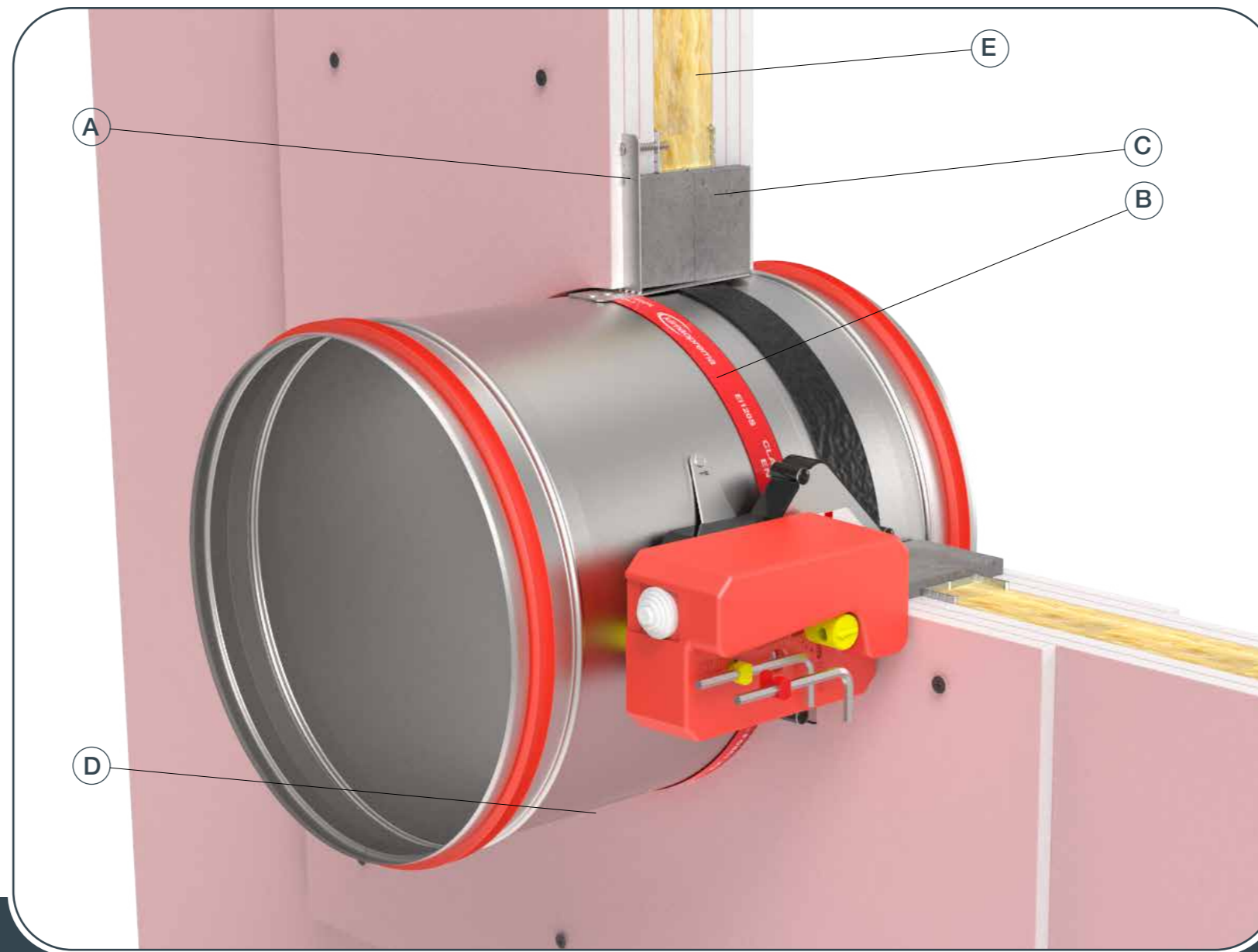

- ▼ [PRODUCT OVERVIEW](#)
- ▼ [DIMENSIONS](#)
- ▼ [INSTALLATIONS](#)
- ▼ [ACTUATORS](#)
- ▼ [ACCESSORIES](#)
- ▼ [REPLACEMENTS](#)
- ▼ [MAINTENANCE AND OPERATION](#)

Possible damper orientations

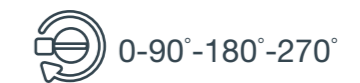

INSTALLATION

FIRE DAMPER - FDC

1. Create an opening in the wall (Ød + 80 mm) x (Ød + 80 mm) and build the subframe according to the drawing, [see page 46](#). Bend the fixing bracket (A) 90°. Place the damper in the opening up to the wall limit mark (B) on the damper.

Damper blade must be closed during the installation!

2. Fix the damper to the wall using screws (bracket screw hole is 6 mm in diameter).

3. Fill the space between the damper and the wall with mortar (C). Cover the mortar with GKF gypsum boards (D) (12,5 mm thick), fix them with self-tapping screws Ø3,5x45 mm.

*Multiple fire dampers can be installed next to each other or ceiling/wall with the minimal distance of 30 mm between them, [see page 45](#).

Test the operation of the damper blade!

FD-A-CSP-BxH
For more details see [pg.51](#)

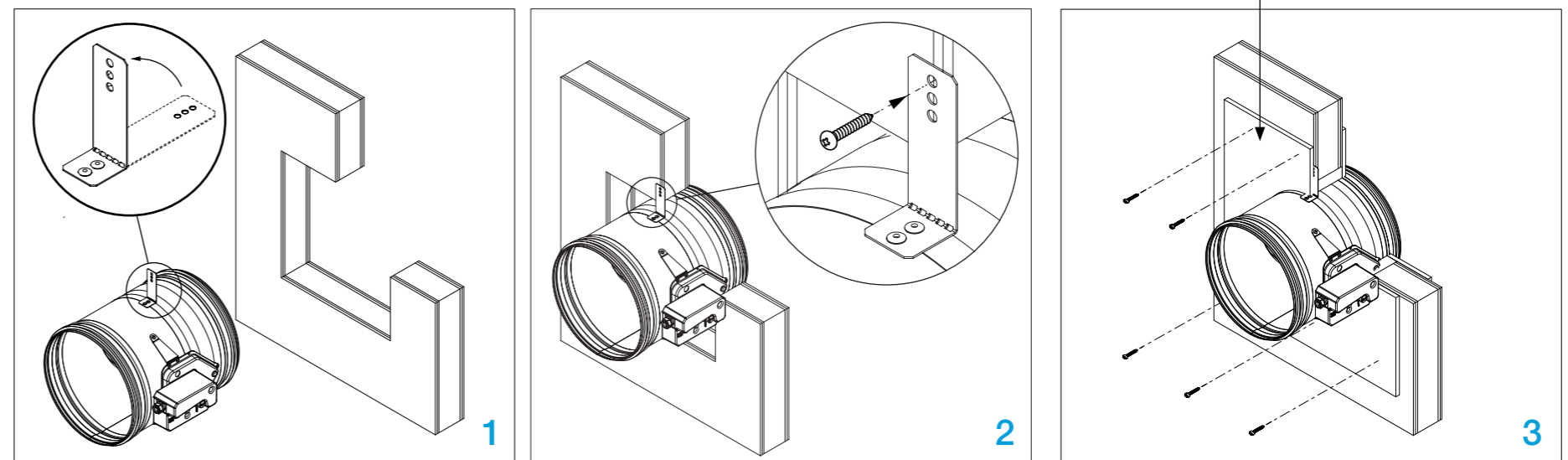

Flexible wall installation (mortar sealing without cover boards)

The wall is composed of 2x2 plasterboard boards, 12,5 mm thick, installed on a steel frame construction. Installation material: gypsum plaster or mortar (C). The minimum thickness of the wall is 100 mm.

EI 120 (ve i↔o)S - FDC 40

The wall is made out of type F (EN520) gypsum plaster boards. To fulfill the classification it is **NOT** mandatory to use the mineral wool inside the wall (mineral wool (E) with density up to 100 kg/m³ can be used).

EI 60 (ve i↔o)S - FDC 25

The wall is made out of type A (EN520) gypsum plaster boards. To fulfill the classification it is **NOT** mandatory to use the mineral wool inside the wall (mineral wool (E) with density up to 60 kg/m³ can be used).



To fulfill the classification it is **NOT** mandatory to use the mineral wool inside the wall (mineral wool (E) with density up to 60 kg/m³ can be used).

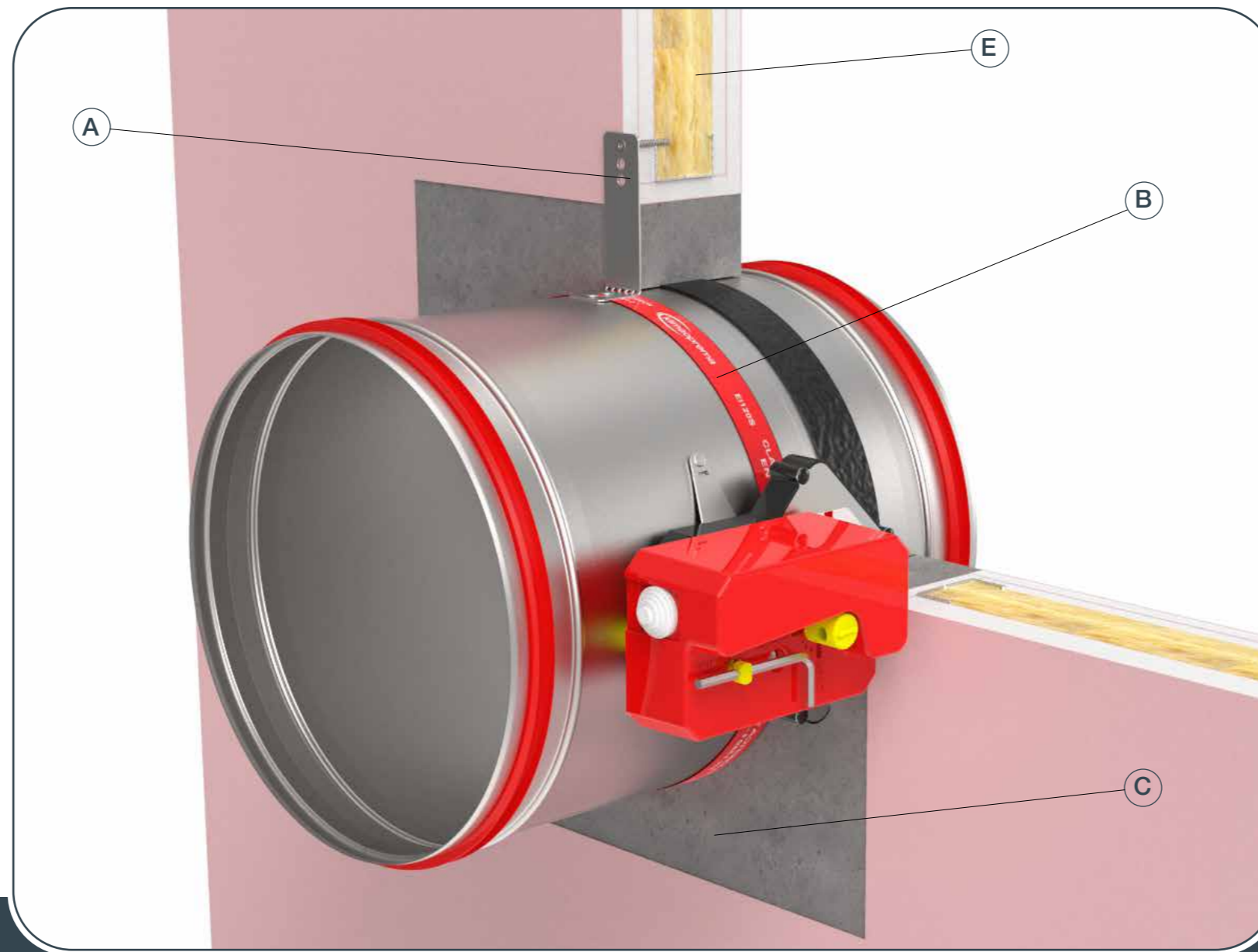

- ▼ [PRODUCT OVERVIEW](#)
- ▼ [DIMENSIONS](#)
- ▼ [INSTALLATIONS](#)
- ▼ [ACTUATORS](#)
- ▼ [ACCESSORIES](#)
- ▼ [REPLACEMENTS](#)
- ▼ [MAINTENANCE AND OPERATION](#)

Possible damper orientations

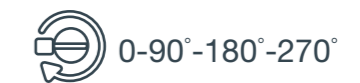

INSTALLATION

FIRE DAMPER - FDC

1. Create an opening in the wall
FDC25 (Ød + 105 mm) x (Ød + 105 mm)
FDC25 (Ød + 120 mm) x (Ød + 120 mm) and build the subframe according to the drawing, [see page 46](#). Bend the fixing bracket (A) 90°. Place the damper in the opening up to the wall limit mark (B) on the damper.

Damper blade must be closed during the installation!

2. Fix the damper to the wall using screws (bracket screw hole is 6 mm in diameter).

3. Fill the space between the damper and the wall with mortar (C).

*Multiple fire dampers can be installed next to each other or ceiling/wall with the minimal distance of 30 mm between them, [see page 45](#).

Test the operation of the damper blade!

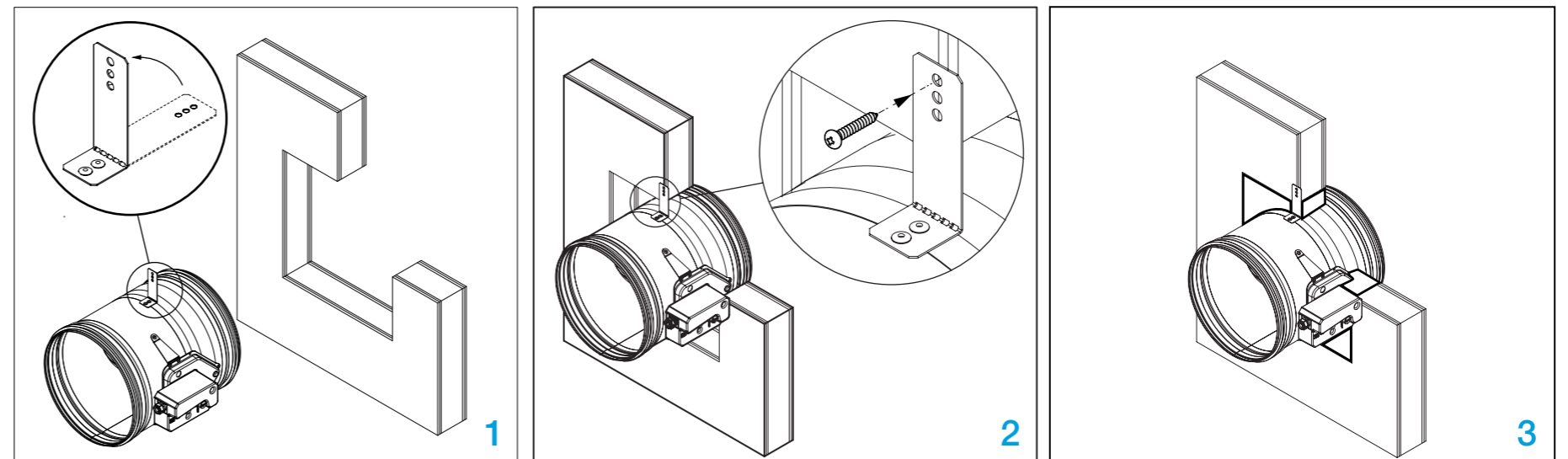

Flexible wall installation (mineral wool sealing)

The wall is composed of 2x2 plasterboard boards, 12,5 mm thick, installed on a steel frame construction. Installation material: mineral wool (C) (minimum density of 100 kg/m³) covered with type F (EI 90) or type A (EI 60) cover boards (D).

The minimum thickness of the wall is 100 mm.

EI 90 (ve i↔o)S

The wall is made out of type F (EN520) gypsum plaster boards. To fulfill the classification it is NOT mandatory to use the mineral wool inside the wall (mineral wool (E) with density up to 100 kg/m³ can be used).

EI 60 (ve i↔o)S

The wall is made out of type A (EN520) gypsum plaster boards. To fulfill the classification it is NOT mandatory to use the mineral wool inside the wall (mineral wool (E) with density up to 40 kg/m³ can be used).

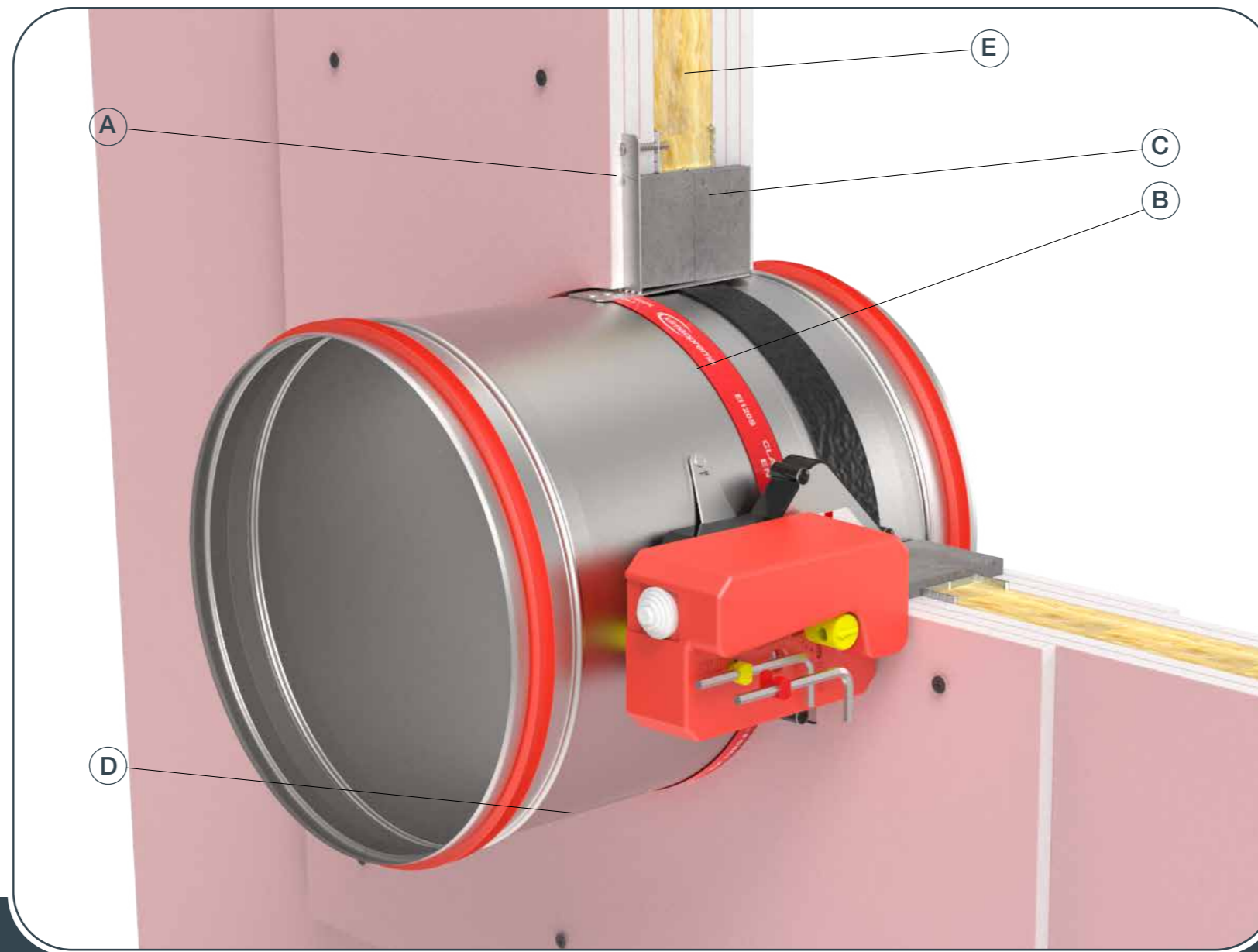

- ▼ [PRODUCT OVERVIEW](#)
- ▼ [DIMENSIONS](#)
- ▼ [INSTALLATIONS](#)
- ▼ [ACTUATORS](#)
- ▼ [ACCESSORIES](#)
- ▼ [REPLACEMENTS](#)
- ▼ [MAINTENANCE AND OPERATION](#)

Possible damper orientations

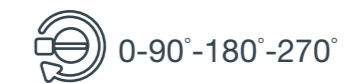

INSTALLATION

FIRE DAMPER - FDC

1. Create an opening in the wall $\text{Ød} + 50...75 \text{ mm}$ x $\text{Ød} + 50...75 \text{ mm}$ and build the subframe according to the drawing, [see page 46](#). Bend the fixing bracket (A) 90°. Place the damper in the opening up to the wall limit mark (B) on the damper.

Damper blade must be closed during the installation!

2. Fix the damper to the wall using screws (bracket screw hole is 6 mm in diameter).

3. Fill the space between the damper and the wall with mineral wool (C). Cover the mineral wool with GKF gypsum boards (D) (12,5 mm thick), fix them with self-tapping screws $\text{Ø}3,5 \times 45 \text{ mm}$.

*Multiple fire dampers can be installed next to each other or ceiling/wall with the minimal distance of 30 mm between them, [see page 45](#).

Test the operation of the damper blade!

FD-A-CSP-BxH

For more details see [pg.51](#)

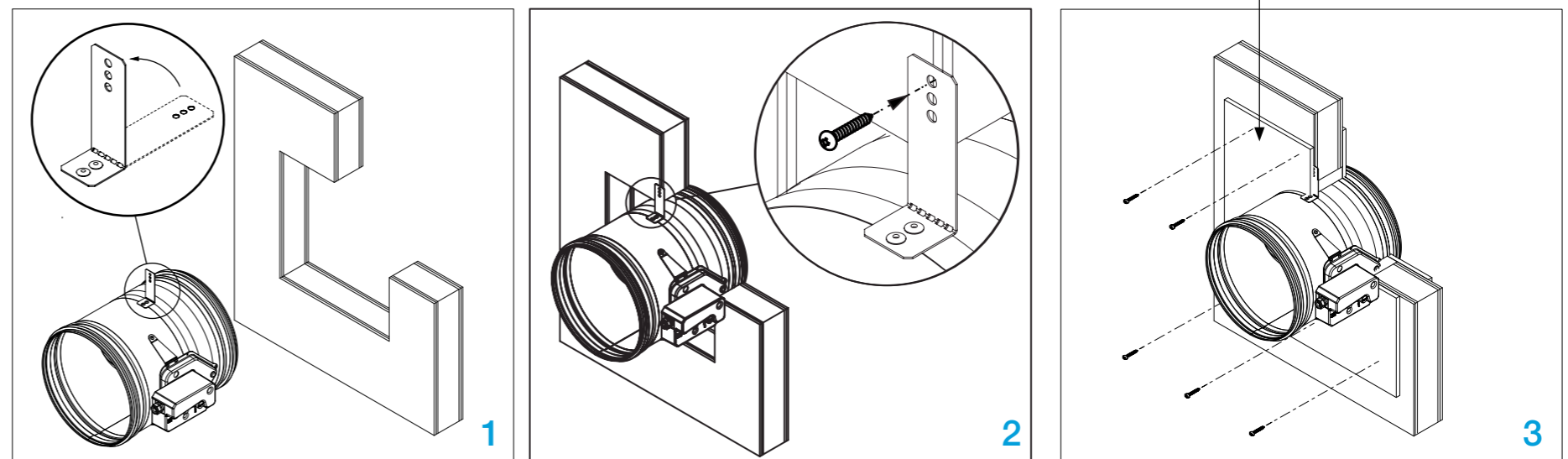

Flexible wall installation (Fire Batt/Weichschott)

The wall is composed of 2x2 plasterboard boards, 12,5 mm thick, installed on a steel frame construction.

EI 90 (ve i→o)S

The wall is made out of type F (EN520) gypsum plaster boards. To fulfill the classification it is **NOT** mandatory to use the mineral wool inside the wall (mineral wool **(E)** with density up to 100 kg/m³ can be used). Installation material: mineral wool **(C)** (minimum density of 140 kg/m³) and fire protection coating **(D)**. The minimum thickness of the wall is 100 mm.

EI 60 (ve i→o)S

The wall is made out of type A (EN520) gypsum plaster boards. To fulfill the classification it is **NOT** mandatory to use the mineral wool inside the wall (mineral wool **(E)** with density up to 60 kg/m³ can be used). Installation material: mineral wool **(C)** (minimum density of 140 kg/m³) and fire protection coating **(D)**. The minimum thickness of the wall is 100 mm.



The minimum thickness of the wall is 100 mm.

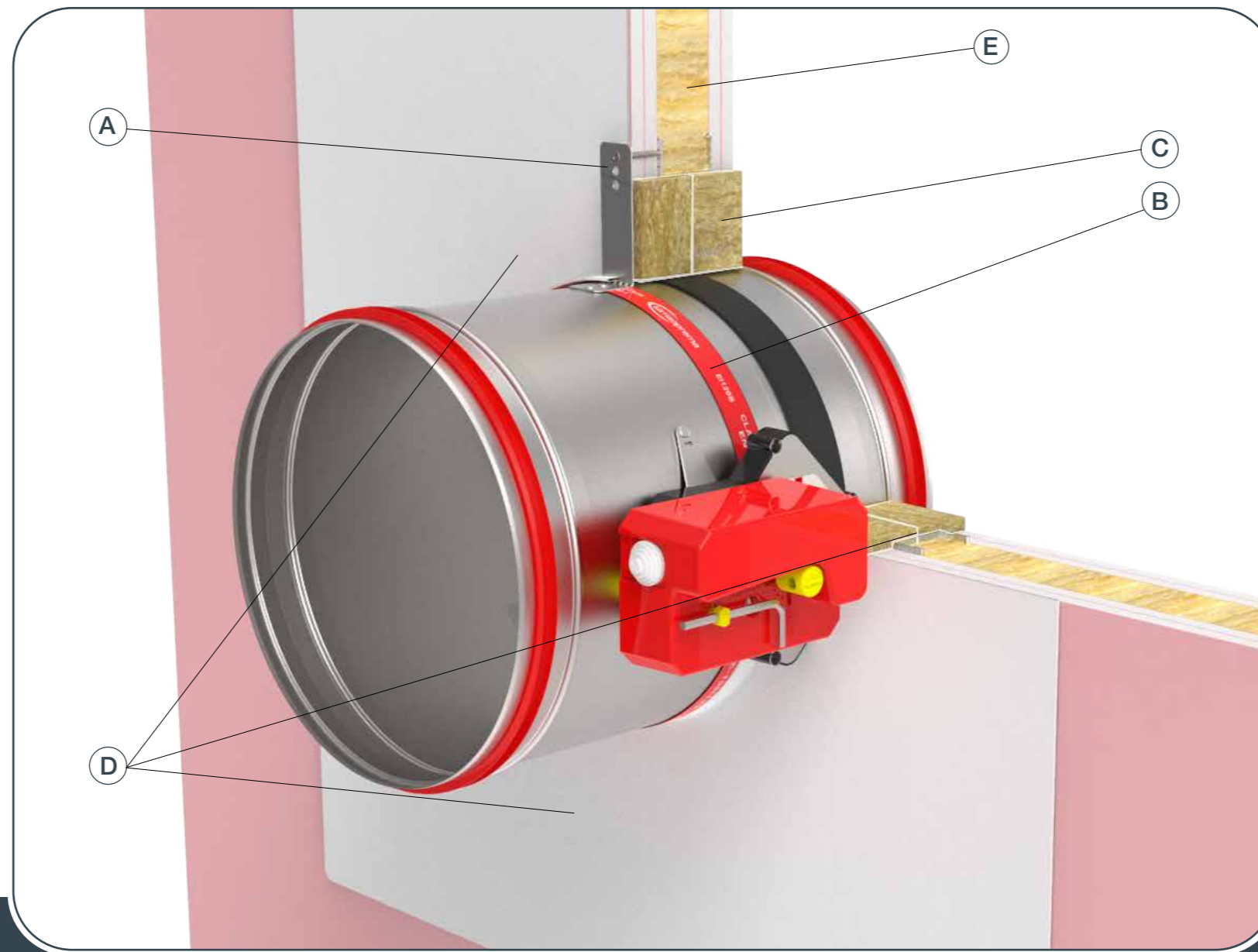

- ▼ [PRODUCT OVERVIEW](#)
- ▼ [DIMENSIONS](#)
- ▼ [INSTALLATIONS](#)
- ▼ [ACTUATORS](#)
- ▼ [ACCESSORIES](#)
- ▼ [REPLACEMENTS](#)
- ▼ [MAINTENANCE AND OPERATION](#)

Possible damper orientations

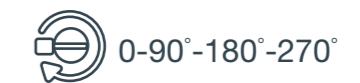

INSTALLATION

FIRE DAMPER - FDC

1. Create an opening in the wall (∅d + 80...300 mm) x (∅d + 80...300 mm) and build the subframe according to the drawing, [see page 46](#). Bend the fixing bracket **(A)** 90°.

2. Place the damper in the opening up to the wall limit mark **(B)** on the damper.

Damper blade must be closed during installation!

3. Close the space between casing and wall with two layers of mineral wool **(C)** (50 mm thick, coated on one side). Seal the connections of mineral wool with intumescent fire resistant sealant **(D)**. Mineral wool and damper casing must be coated with 2 mm thick fire protection coating. Damper casing should be coated up to profile protrusions.

*Multiple fire dampers can be installed next to each other or ceiling/wall with the minimal distance of 30 mm between them, [see page 45](#).

Test the operation of the damper blade!

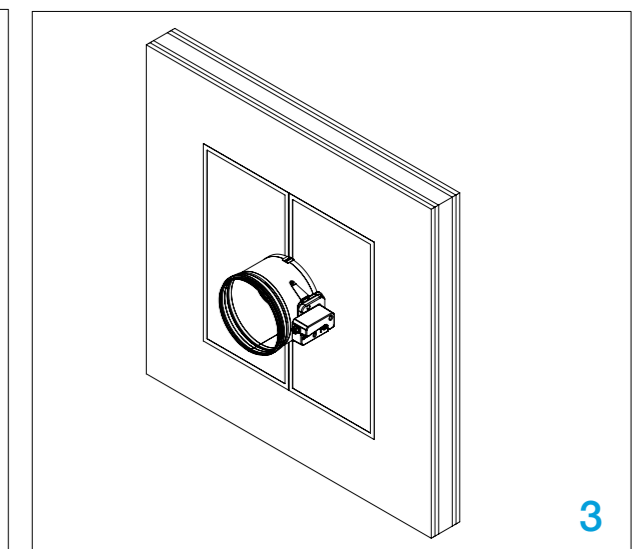
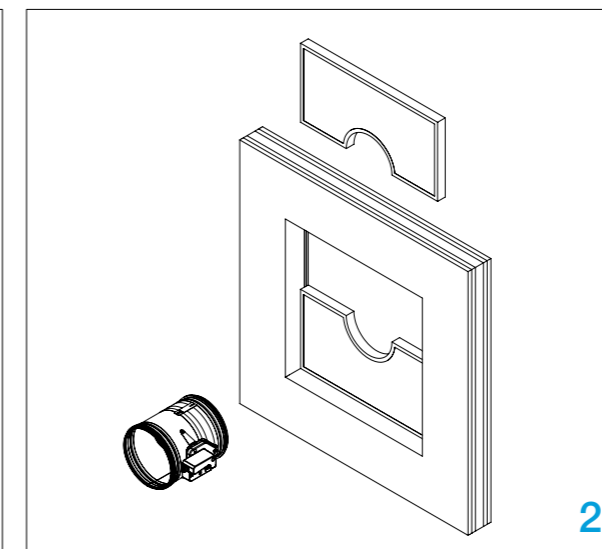
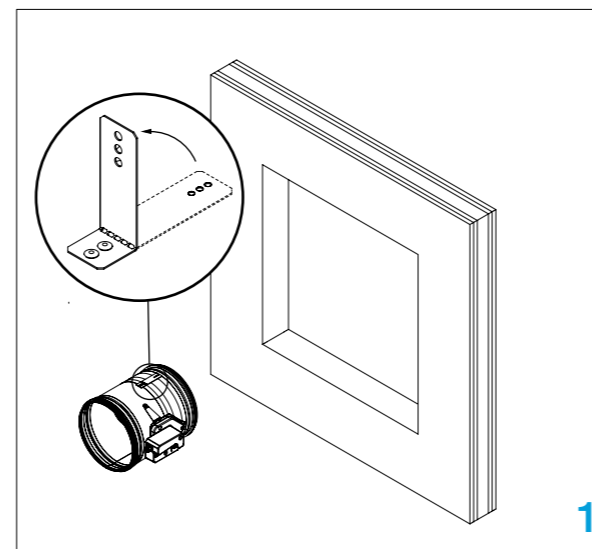

Flexible wall installation- 75 mm (Fire Batt/Weichschott)

The wall is composed of 1x1 plasterboard boards, 12,5 mm thick, installed on a steel frame construction.

EI 45 (ve i→o)S

The wall is made out of type F (EN520) gypsum plaster boards. To fulfill the classification it is **NOT** mandatory to use the mineral wool inside the wall (mineral wool **(E)** with density up to 115 kg/m³ can be used). Installation material: mineral wool **(C)** (minimum density of 140 kg/m³) and fire protection coating **(D)**. The minimum thickness of the wall is 75 mm.



INSTALLATION

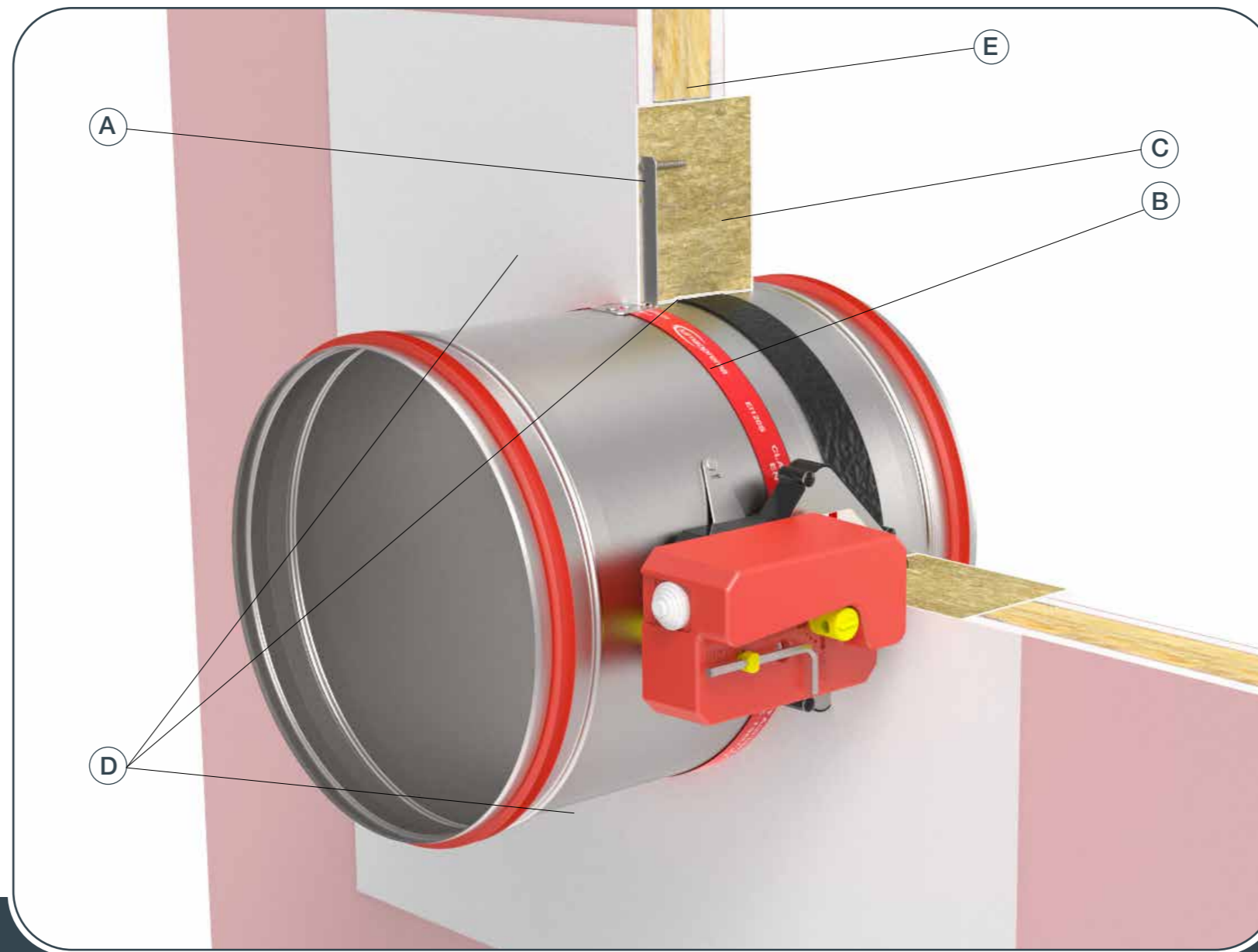

- ▼ [PRODUCT OVERVIEW](#)
- ▼ [DIMENSIONS](#)
- ▼ [INSTALLATIONS](#)
- ▼ [ACTUATORS](#)
- ▼ [ACCESSORIES](#)
- ▼ [REPLACEMENTS](#)
- ▼ [MAINTENANCE AND OPERATION](#)

Possible damper orientations

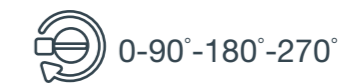

FIRE DAMPER - FDC

1. Create an opening in the wall (Ød + 80...300 mm) x (Ød + 80...300 mm) and build the subframe according to the drawing, [see page 46](#). Bend the fixing bracket **(A)** 90°.

2. Place the damper in the opening up to the wall limit mark **(B)** on the damper.

Damper blade must be closed during installation!

3. Close the space between casing and wall with two layers of mineral wool **(C)** (50 mm thick, coated on one side). On the side opposite the driveway, leave the wool 25 mm outside the wall. Seal the connections of mineral wool with intumescent fire resistant sealant **(D)**. Mineral wool and damper casing must be coated with 2 mm thick fire protection coating. Damper casing should be coated up to profile protrusions.

*Multiple fire dampers can be installed next to each other or ceiling/wall with the minimal distance of 30 mm between them, [see page 45](#).

Test the operation of the damper blade!

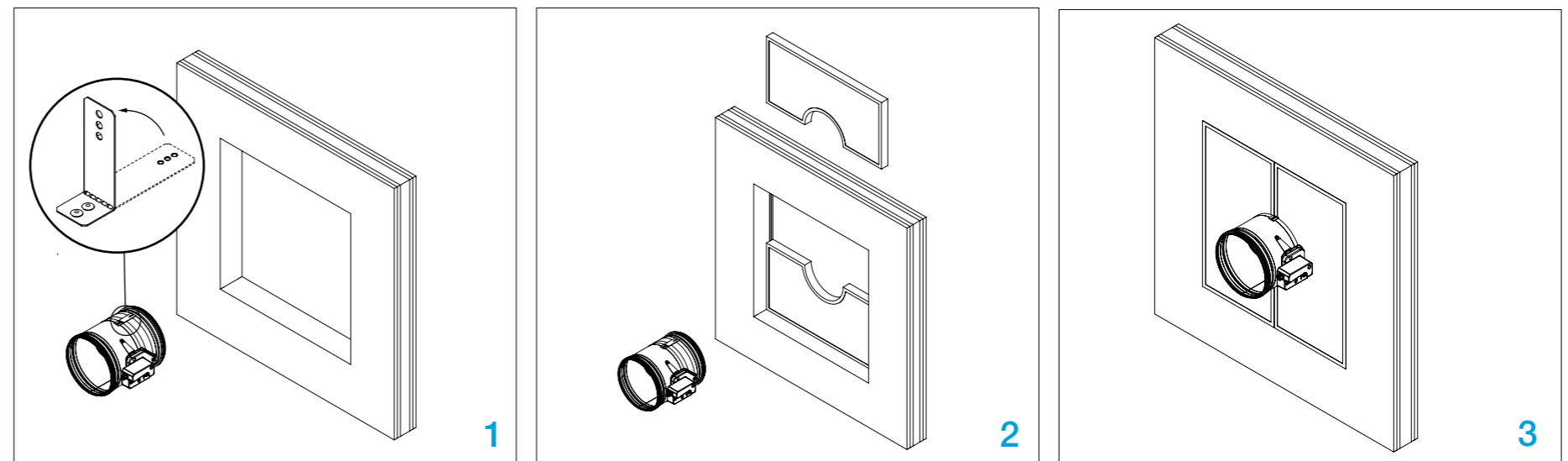

Flexible wall installation CLT wall (Fire Batt/ Weichschott)

Fire dampers are mounted in CLT (Cross laminated timber) wooden wall with density 480 kg/m³. Wall is made of 3 layers (30 – 40 – 30mm).

EI 90 (ve i↔o)S

Installation material: Mineral wool (minimum density of 140 kg/m³, fire protection coating).



INSTALLATION

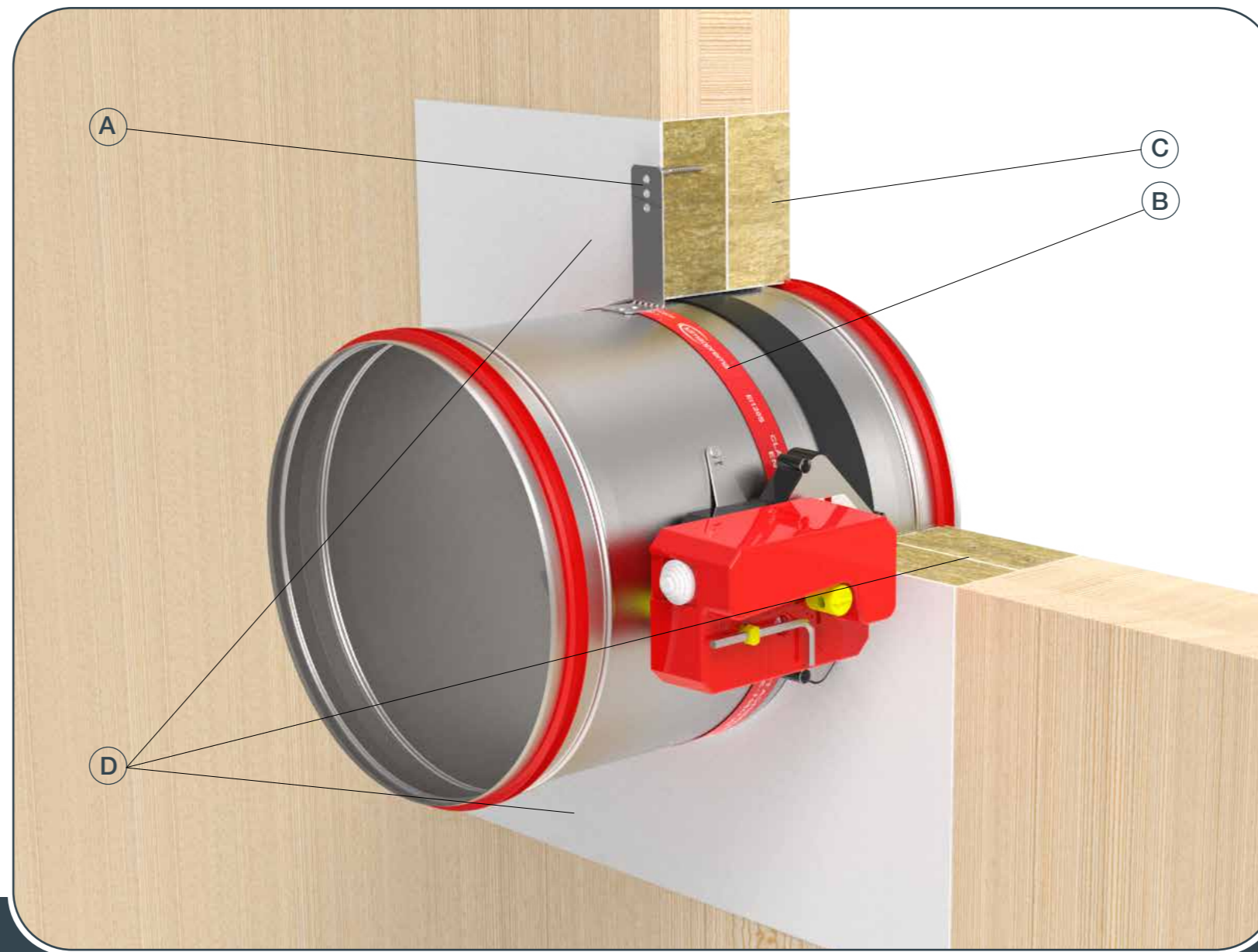

- ▼ [PRODUCT OVERVIEW](#)
- ▼ [DIMENSIONS](#)
- ▼ [INSTALLATIONS](#)
- ▼ [ACTUATORS](#)
- ▼ [ACCESSORIES](#)
- ▼ [REPLACEMENTS](#)
- ▼ [MAINTENANCE AND OPERATION](#)

Possible damper orientations

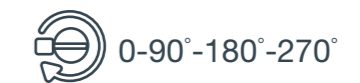

FIRE DAMPER - FDC

1. Create an opening in the wall
($\varnothing d + 80 \dots 300$ mm) x ($\varnothing d + 80 \dots 300$ mm)
Bend the fixing bracket **(A)** 90°.

2. Place the damper in the opening up to the wall
limit mark **(B)** on the damper.

Damper blade must be closed during installation!

3. Close the space between casing and wall with
two layers of mineral wool **(C)**
(50 mm thick, coated on one side). Seal the
connections of mineral wool with intumescent fire
resistant sealant **(D)**. Mineral wool and damper
casing must be coated with 2 mm thick fire
protection coating. Damper casing should be coated
up to profile protrusions.

Test the operation of the damper blade!

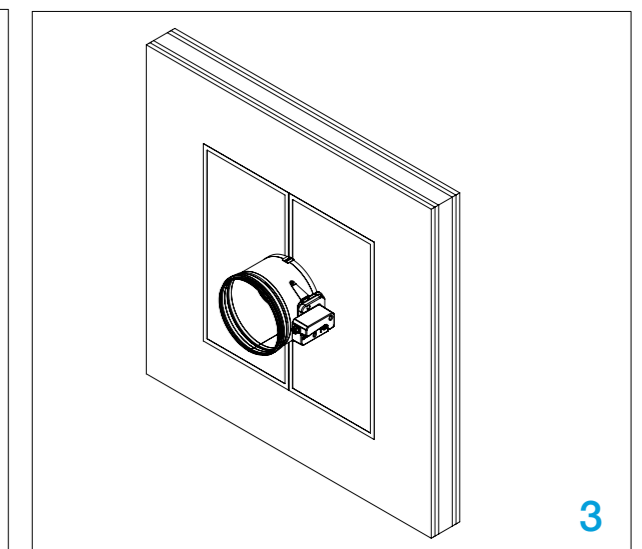
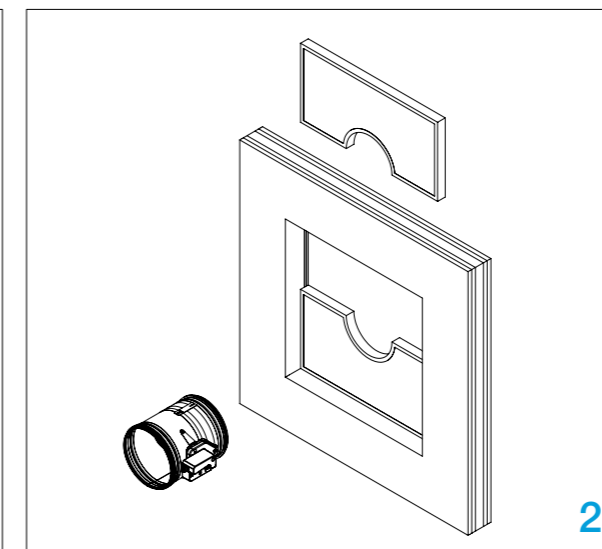
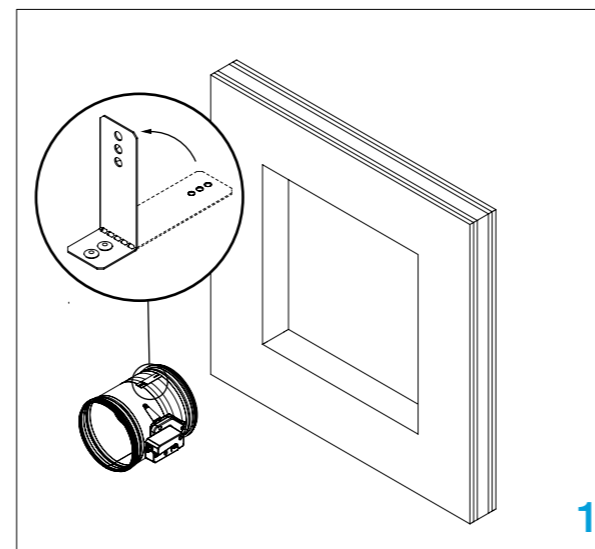

Flexible wall installation Eurobond

The wall is composed of Eurobond Firemaster boards, in 100 mm thickness, installed in a steel frame construction.

FDC 25 EI 60 (i↔o)S

FDC 40 EI 60 (i↔o)S

Sealing between dampers and wall is 2 layers of Rockwool Firepro 50 mm thick sealed with intumescent fire resistant sealant.



INSTALLATION

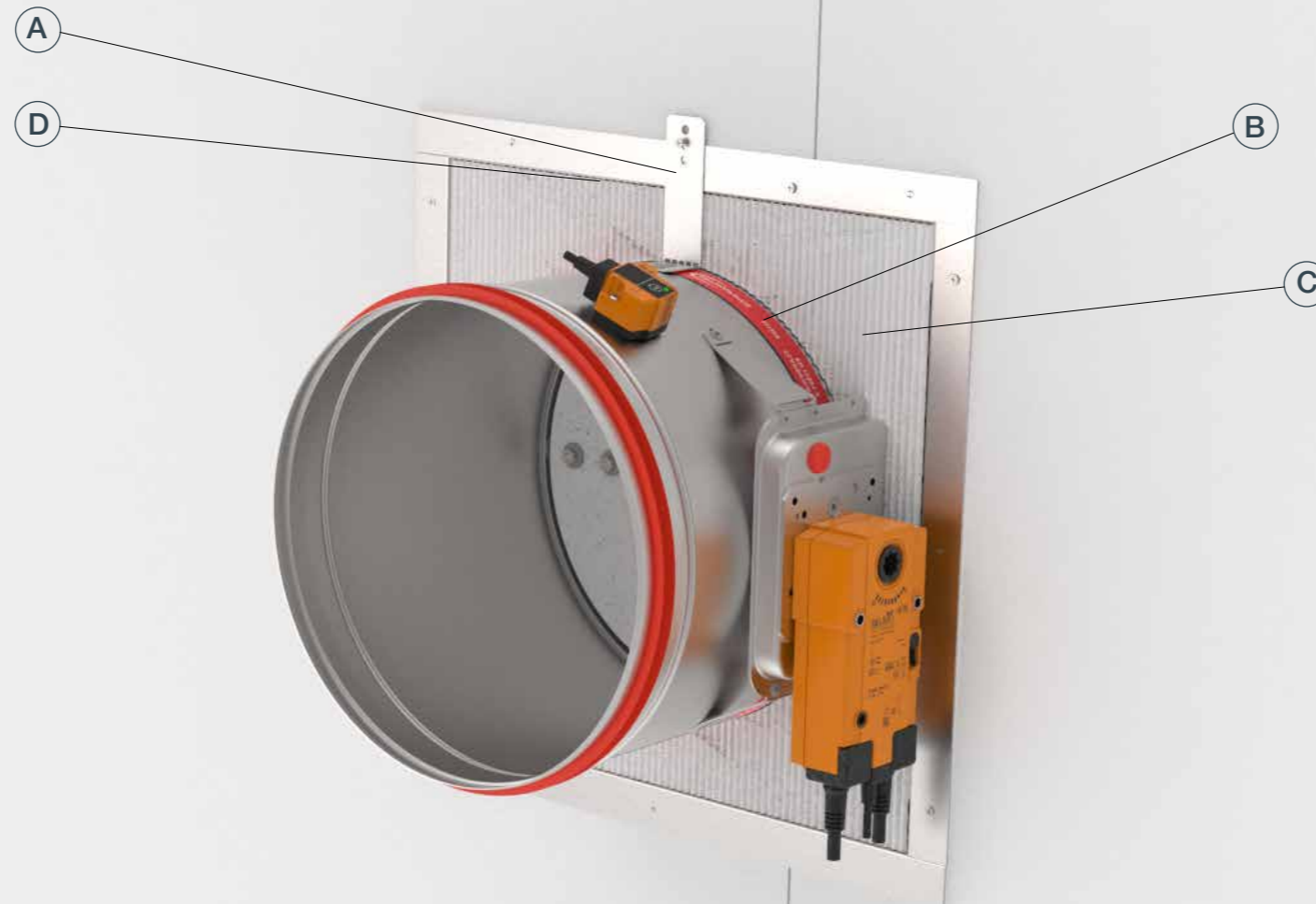

- ▼ [PRODUCT OVERVIEW](#)
- ▼ [DIMENSIONS](#)
- ▼ [INSTALLATIONS](#)
- ▼ [ACTUATORS](#)
- ▼ [ACCESSORIES](#)
- ▼ [REPLACEMENTS](#)
- ▼ [MAINTENANCE AND OPERATION](#)

Possible damper orientations

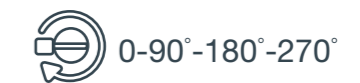

FIRE DAMPER - FDC

Create the wall, see [Technical drawing](#)

1. Make the opening in the wall $\varnothing d + 100$ mm on the connection of two boards. The opening is re-inforced with L profiles 30x30x2mm and screws 6,3x25 on one sides and 6,3x120mm on other side. The opening must be coated with 2 mm thick fire protection coating.

2. Bend the fixing bracket (A) 90°. Place the damper in the opening up to the wall limit mark (B) on the damper.

Damper blade must be closed during installation!

3. Close the space between casing and wall with two layers of mineral wool (C) (50 mm thick, coated on one side). Seal the connections of mineral wool with intumescent fire resistant sealant. Mineral wool and damper casing must be coated with 2 mm thick fire protection coating (D). Damper casing should be coated up to profile protrusions.

Test the operation of the damper blade!

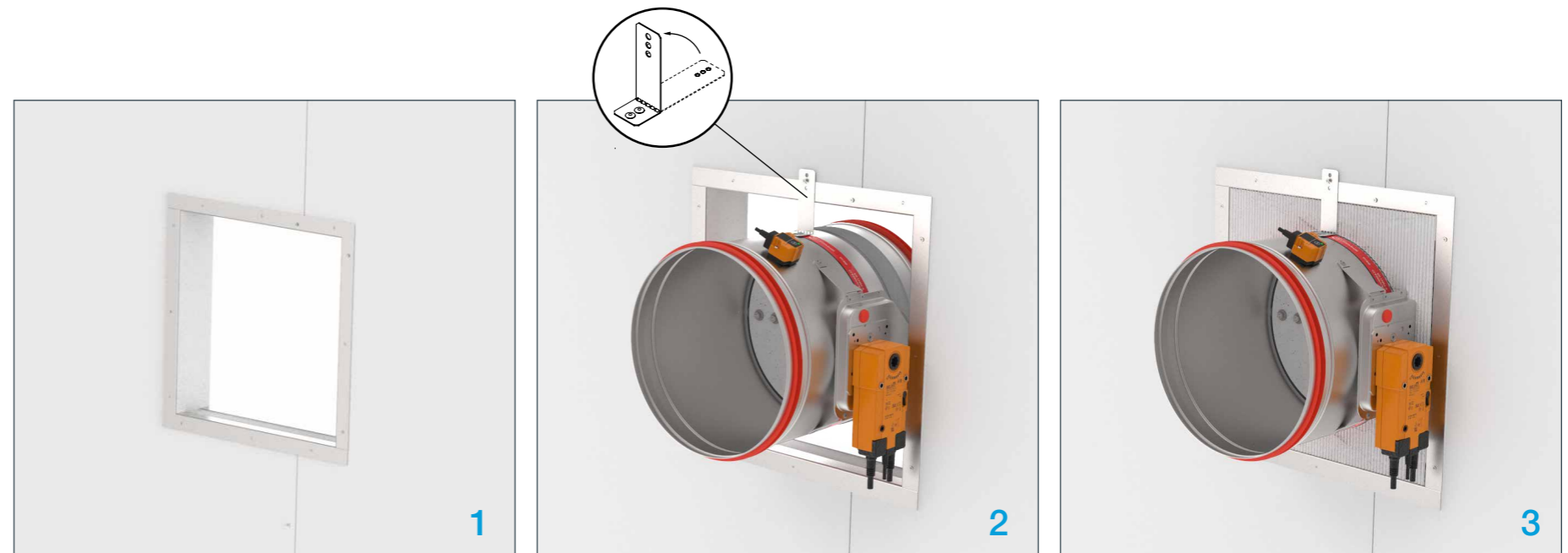

Flexible ceiling joint Gypsum blocks flexibile wall

The wall is composed out of gypsum blocks (minimum density of 450 kg/m³) and with minimum thickness of 100 mm. Installation material is gypsum plaster (C) and mineral wool (70 kg/m³) (E), thickness of the wool is 40 mm.



INSTALLATION

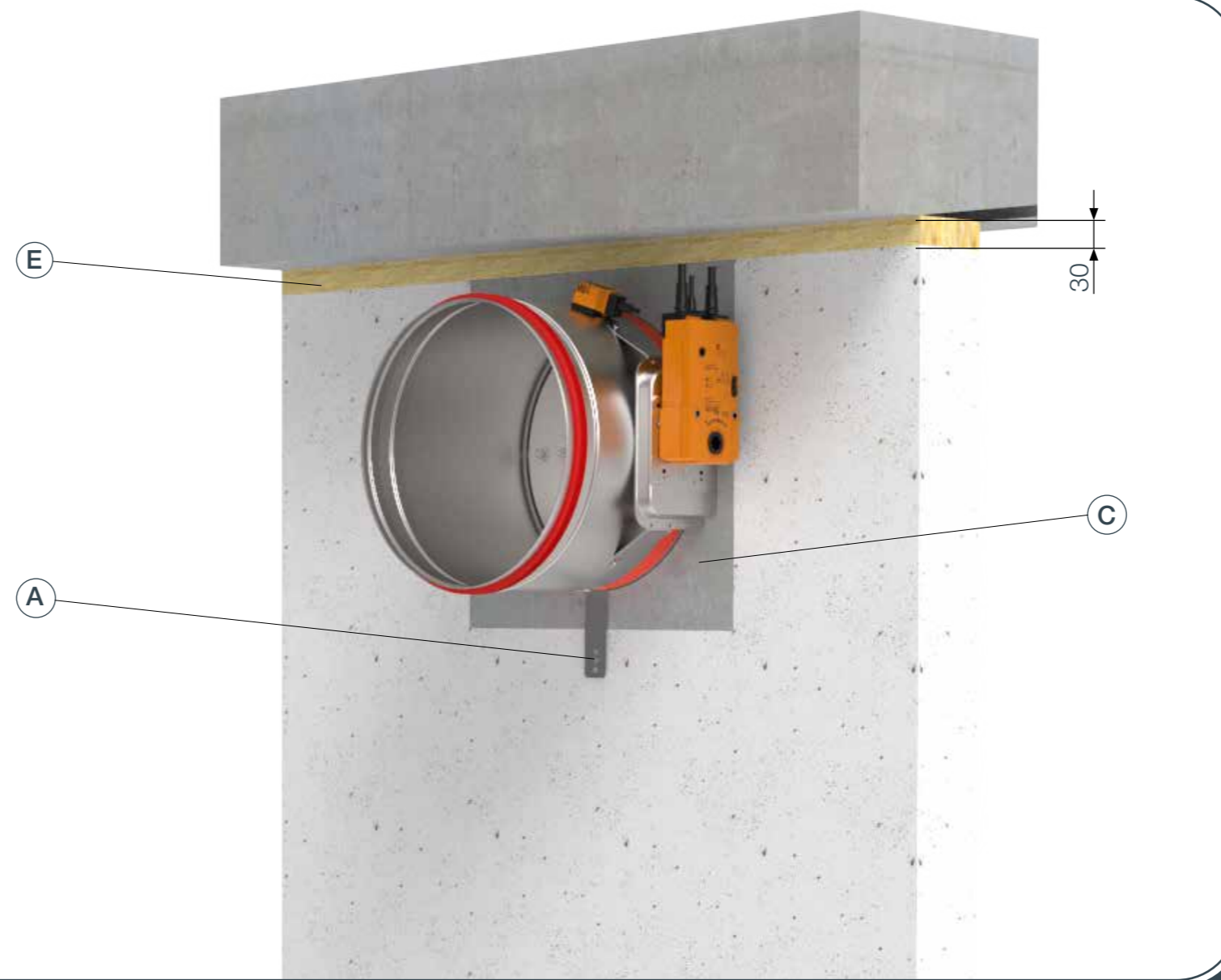

- ▼ [PRODUCT OVERVIEW](#)
- ▼ [DIMENSIONS](#)
- ▼ [INSTALLATIONS](#)
- ▼ [ACTUATORS](#)
- ▼ [ACCESSORIES](#)
- ▼ [REPLACEMENTS](#)
- ▼ [MAINTENANCE AND OPERATION](#)

Possible damper orientations

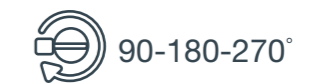

FIRE DAMPER - FDC

1. Create an opening in the wall Ød + 80 mm, 30mm below the ceiling.

2. Bend the fixing bracket (A) 90°. Insert the fire damper into the opening and fix the mounting bracker with self taping screw (3,5 x 35 mm)

3. Fill the space between the damper and the wall with gypsum plaster/ mortar.

4. Fill the space between the ceiling and the wall with mineral wool (70 kg/m³, thickness 40 mm).

Damper blade must be closed during installation!

Test the operation of the damper blade!

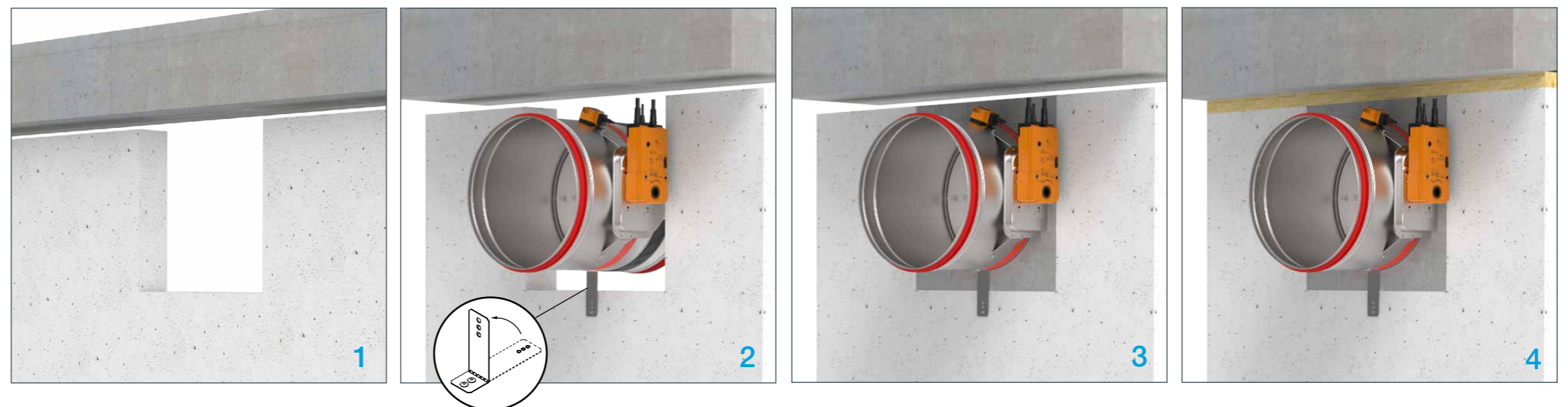

Flexible ceiling joint Plasterboard type F flexibile wall

The wall is composed of 2x2 plasterboard boards, 12,5 mm thick, installed on a steel frame construction. To fulfill the classification it is **NOT** mandatory to use the mineral wool inside the wall (mineral wool with density up to 100 kg/m³ can be used). The minimum thickness of the wall is 100 mm. Installation material is gypsum plaster (C) and mineral wool (115 kg/m³) (E), thickness of the wool is 50 mm.

[Technical drawing of the construction of the wall](#)
[Technical drawing](#)



INSTALLATION

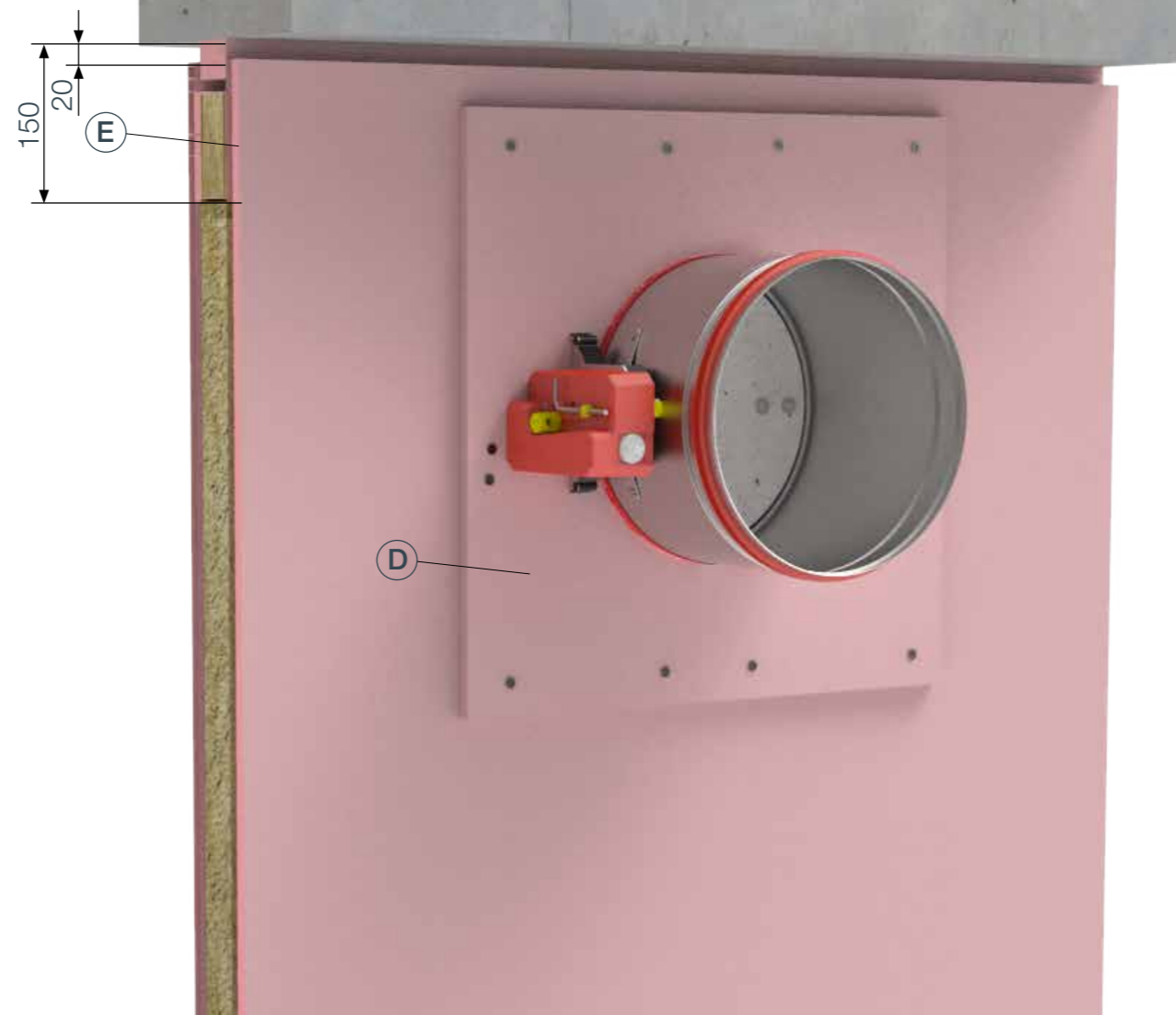

- ▼ [PRODUCT OVERVIEW](#)
- ▼ [DIMENSIONS](#)
- ▼ [INSTALLATIONS](#)
- ▼ [ACTUATORS](#)
- ▼ [ACCESSORIES](#)
- ▼ [REPLACEMENTS](#)
- ▼ [MAINTENANCE AND OPERATION](#)

Possible damper orientations

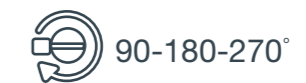

FIRE DAMPER - FDC

1. Prepare subconstruction and cladding of the wall with gypsum boards acc. to technical drawing. Take care that cladding of the wall is not connected to profile connected to the ceiling so it could compensate movement of the ceiling without impact to the wall. Fill the space between the ceiling segment and the wall with mineral wool. Create an opening in the wall $\varnothing + 80$ mm.

2. Bend the fixing bracket 90°. Insert the fire damper into the opening and fix the mounting bracket with self tapping screw (3,5 x 35 mm)

3. Fill the space between the damper and the wall with gypsum plaster/ mortar.

4. Cover the mineral wool with GKF gypsum boards (D) (12,5 mm thick), fix them with self-tapping screws $\varnothing 3,5 \times 45$ mm.

Damper blade must be closed during installation!
Test the operation of the damper blade!

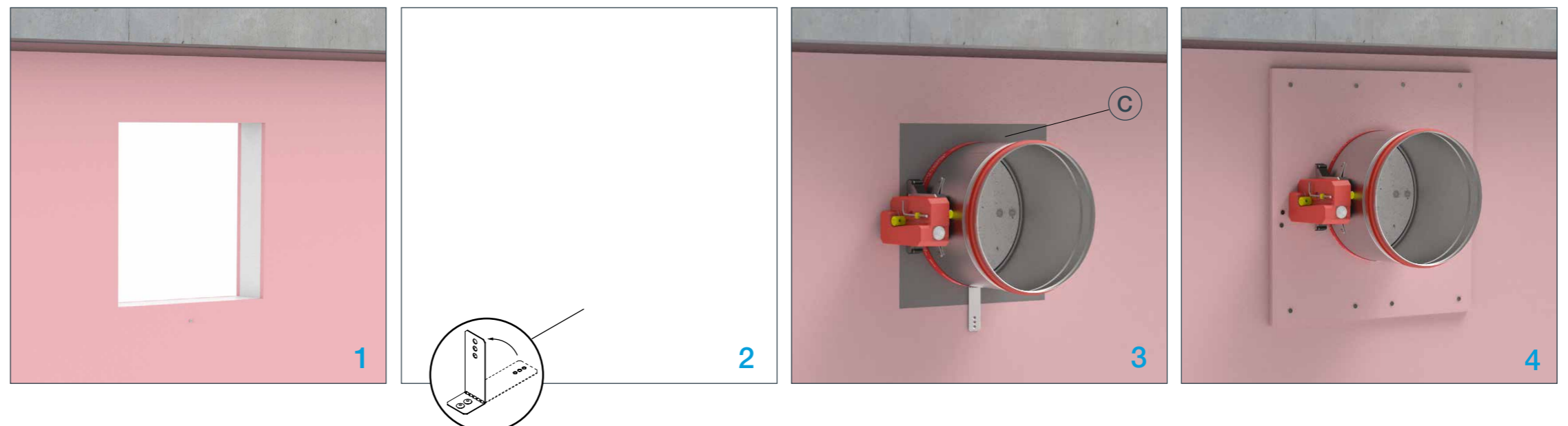

Rigid floor/ceiling installation (mortar sealing)

The floor/ceiling is composed of concrete blocks (minimum density of 450 kg/m³) or reinforced concrete (minimum density of 2200 kg/m³) and with a minimum thickness of 100 mm. Installation material is gypsum plaster or mortar (C).



INSTALLATION

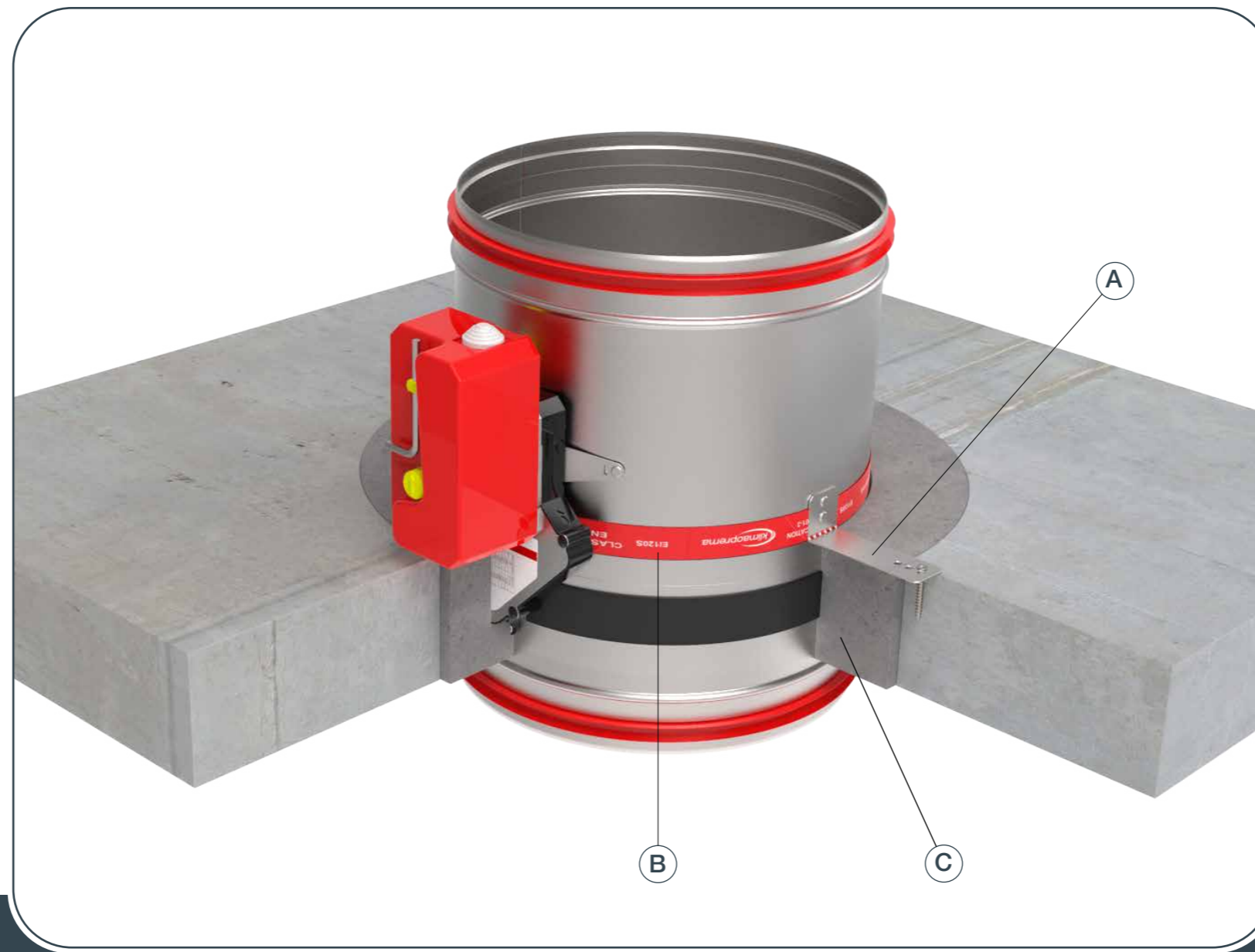

- ▼ [PRODUCT OVERVIEW](#)
- ▼ [DIMENSIONS](#)
- ▼ [INSTALLATIONS](#)
- ▼ [ACTUATORS](#)
- ▼ [ACCESSORIES](#)
- ▼ [REPLACEMENTS](#)
- ▼ [MAINTENANCE AND OPERATION](#)

Possible damper orientations



FIRE DAMPER - FDC

1. Create an opening in the floor/ceiling (minimal dimensions on [pg.14](#)) and bend the fixing bracket (A) 90°. Place the damper in the opening up to the wall limit mark (B) on the damper.

Damper blade must be closed during installation!

2. Fix the damper to the slab using screws (bracket screw hole is 6 mm in diameter).

3/3*. Fill the space between the damper and the slab with mortar (C) or gypsum plaster.

Test the operation of the damper blade!

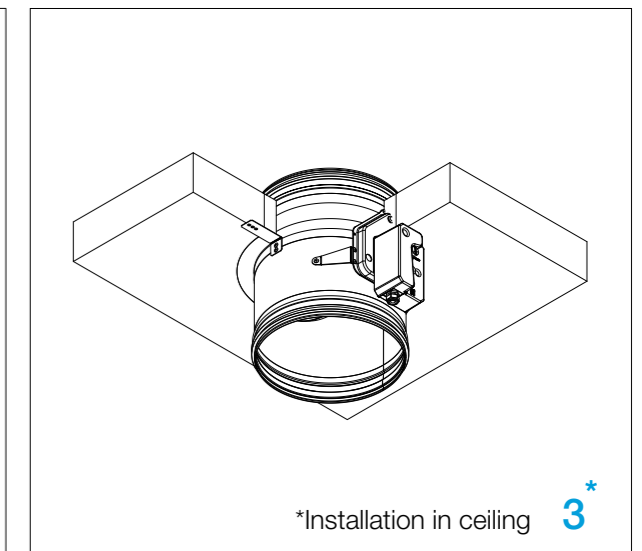
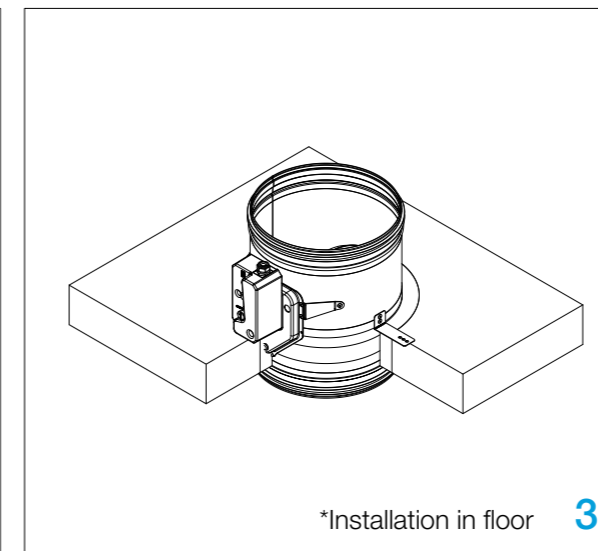
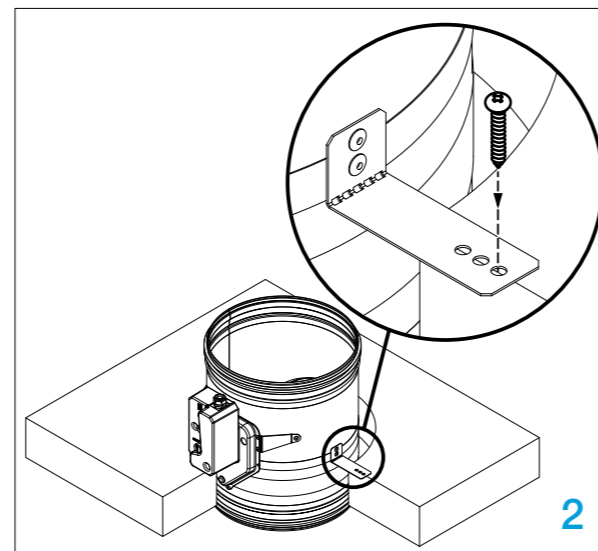
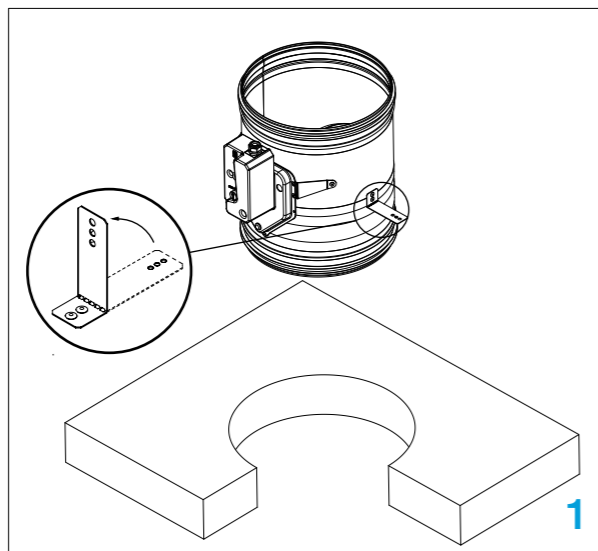

Rigid floor/ceiling installation (Fire Batt/ Weichschott)

The floor/ceiling is composed of concrete blocks (minimum density of 450 kg/m³) or reinforced concrete (minimum density of 2200 kg/m³) and with a minimum thickness of 100 mm.
Installation material: Mineral wool (C) (minimum density of 140 kg/m³), fire protection coating (D).

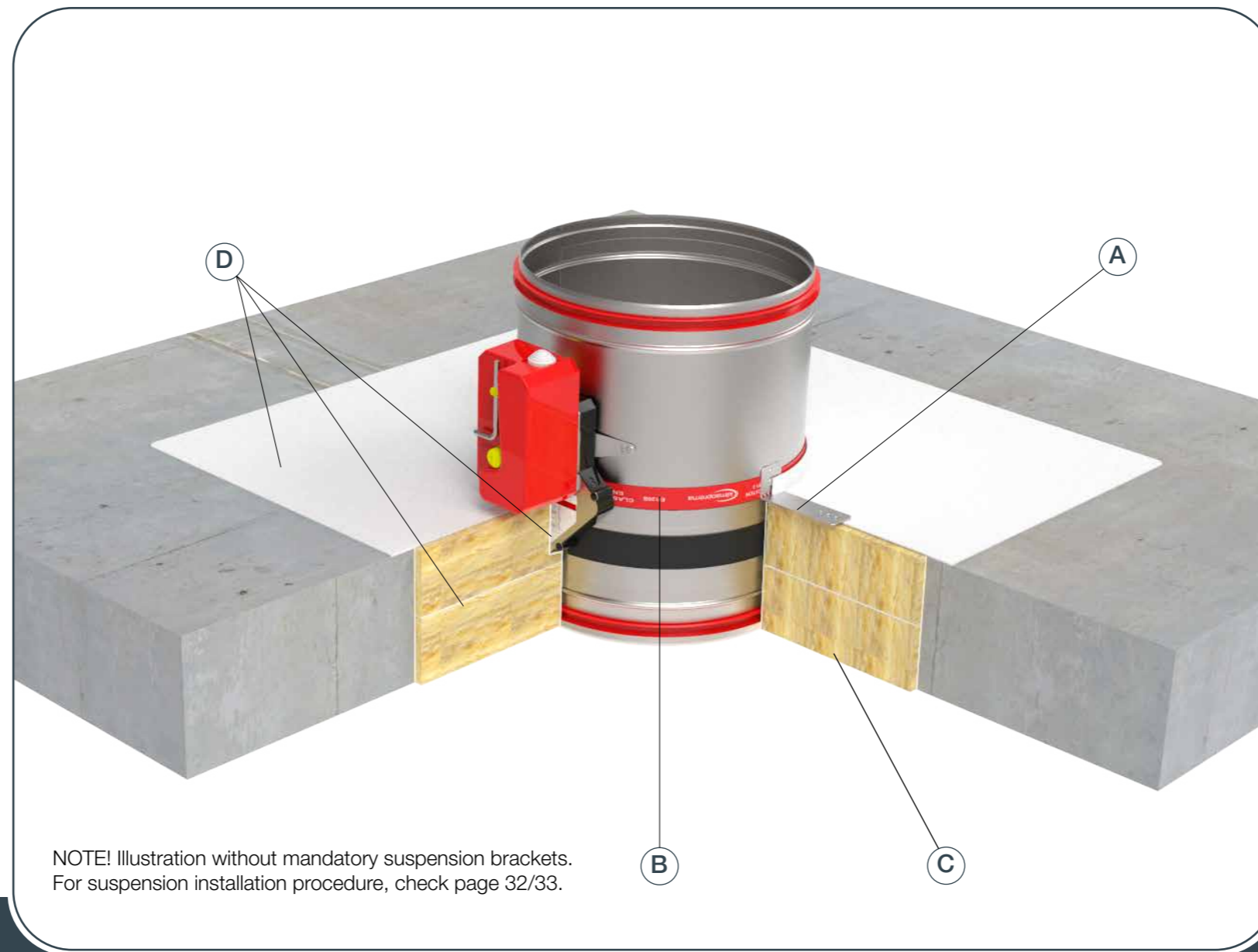

NOTE! Illustration without mandatory suspension brackets.
For suspension installation procedure, check page 32/33.

- ▼ [PRODUCT OVERVIEW](#)
- ▼ [DIMENSIONS](#)
- ▼ [INSTALLATIONS](#)
- ▼ [ACTUATORS](#)
- ▼ [ACCESSORIES](#)
- ▼ [REPLACEMENTS](#)
- ▼ [MAINTENANCE AND OPERATION](#)

Possible damper orientations



INSTALLATION

FIRE DAMPER - FDC

1. Create an opening in the floor/ceiling (Ød + 80...300 mm) x (Ød + 80...300 mm). Bend the fixing bracket (A) 90°.

*Fire Batt floor/ceiling installations require a suspension for the fire damper. For more details, see [page 33 rigid floor](#) / [page 34 ceiling](#).

2. Place the damper in the opening up to the wall limit mark (B) on the damper. Close the space between casing and floor/ceiling with two layers of mineral wool (C) (50 mm thick, coated on one side).

Test the operation of the damper blade!

Damper blade must be closed during installation!

3/3*. Connections of mineral wool should be sealed with intumescent fire resistant sealant (D). Mineral wool and damper casing must be coated with 2 mm thick fire protection coating. Damper casing should be coated up to profile protrusions.

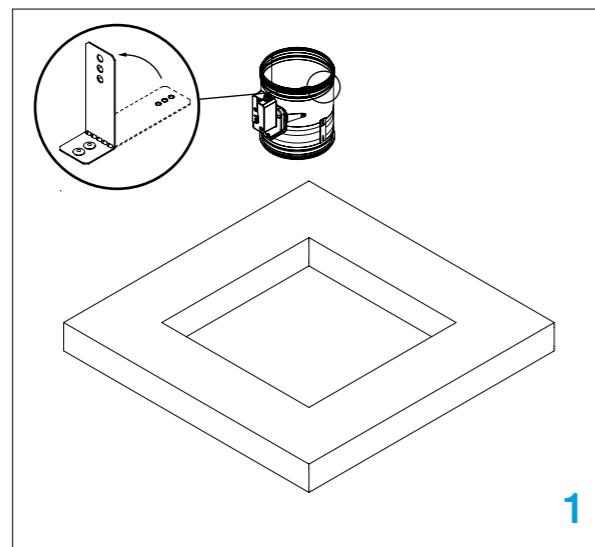

1

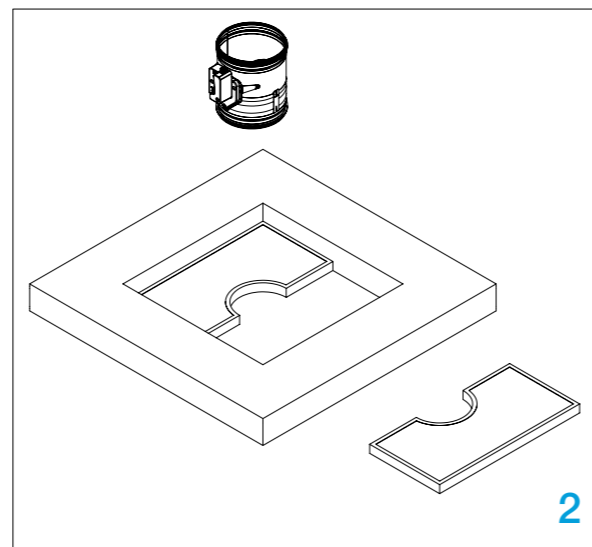

2

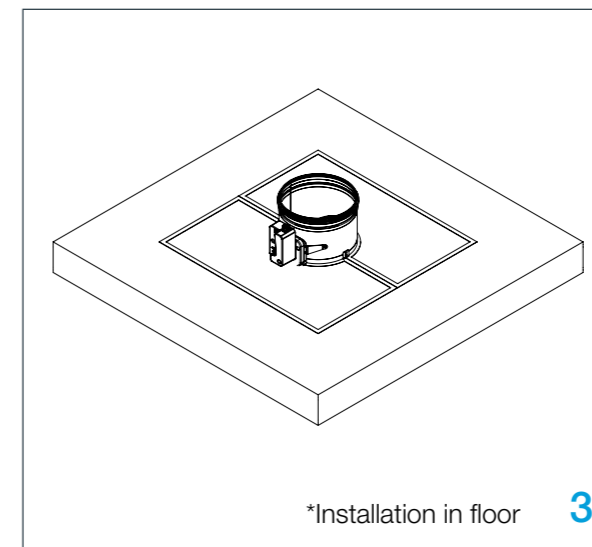

*Installation in floor

3

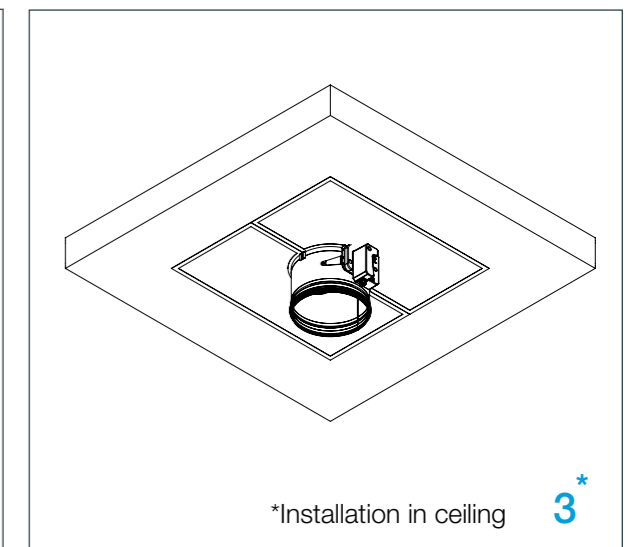

*Installation in ceiling

3*

Suspension for rigid floor installation

Suspension systems are required for the Fire Batt/Weichschott installation of the fire damper with mineral wool in floor slabs. Fire dampers can be suspended from solid ceiling slabs using adequately sized threaded rods. Load the suspension system only with the weight of the fire damper. Ducts must be suspended separately.



INSTALLATION

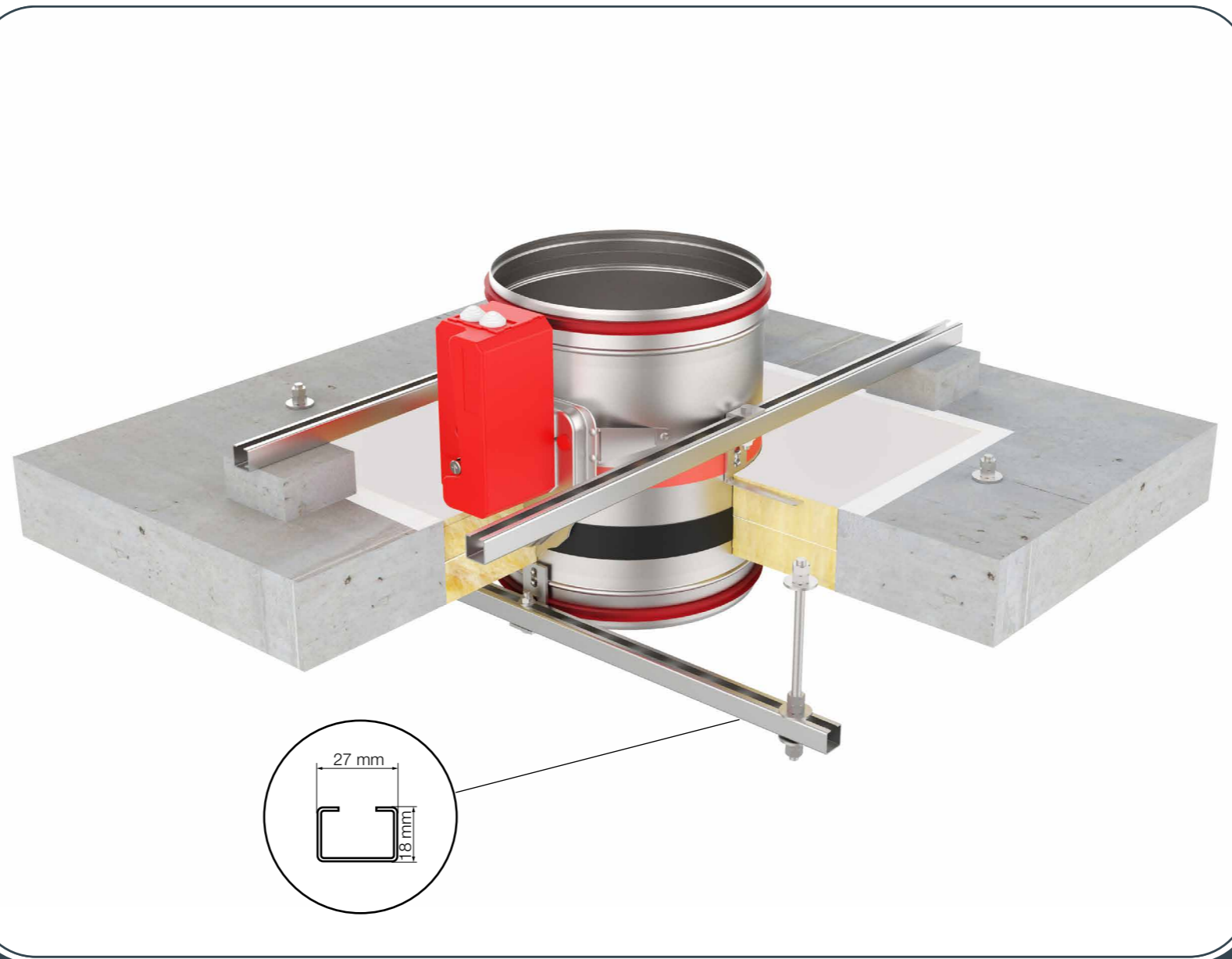

- ▼ [PRODUCT OVERVIEW](#)
- ▼ [DIMENSIONS](#)
- ▼ [INSTALLATIONS](#)
- ▼ [ACTUATORS](#)
- ▼ [ACCESSORIES](#)
- ▼ [REPLACEMENTS](#)
- ▼ [MAINTENANCE AND OPERATION](#)

Possible damper orientations



FIRE DAMPER - FDC

1. Suspension strut should be connected with drop rods (8/10 mm) to the floor slab above. It is used to support the damper and ease the installation.
2. When using L profile fixation, support steel C profile with 50 mm high piece of aerated concrete or similar rigid material. Not necessary if connecting rods directly to damper.
3. Damper casing is fixed to suspended and supported steel C profiles by two self tapping screws 4,8x16 (**make sure that it doesn't interfere with damper blade**) with L profile hanger (**detail A**) fixed to steel C profiles by M8 screw and nut. Position of self-tapping screws is trough the middle of damper casing.
4. To finish the installation please follow the steps (2.-4.) from [page 32](#).

Damper blade must be closed during installation!
Test the operation of the damper blade!

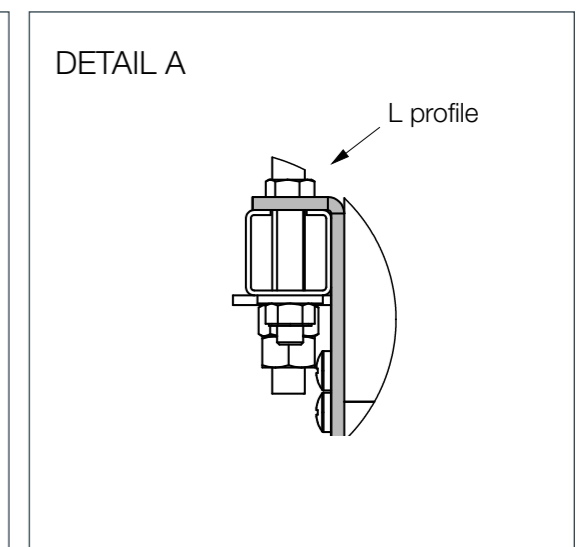
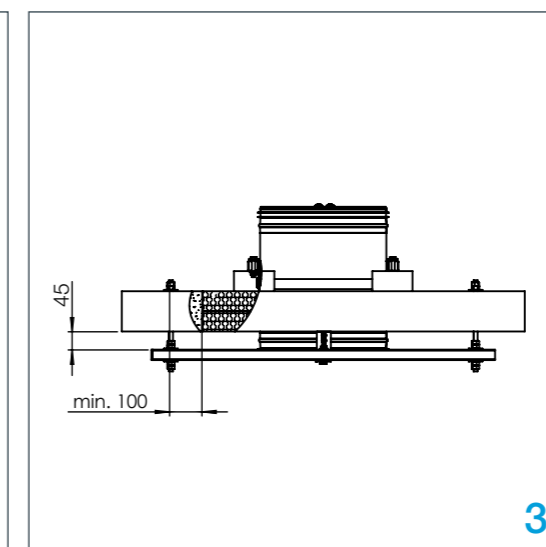
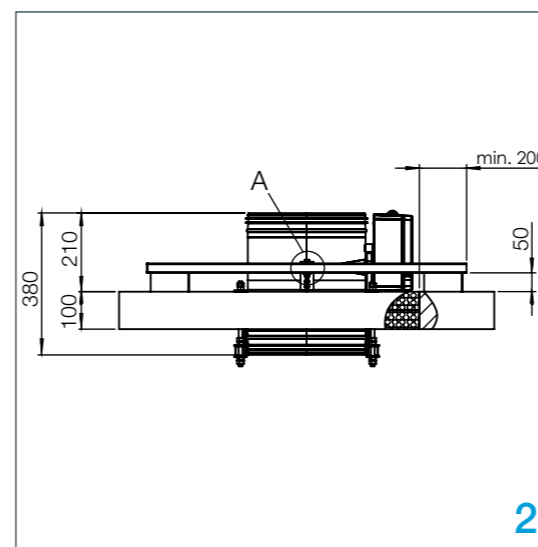
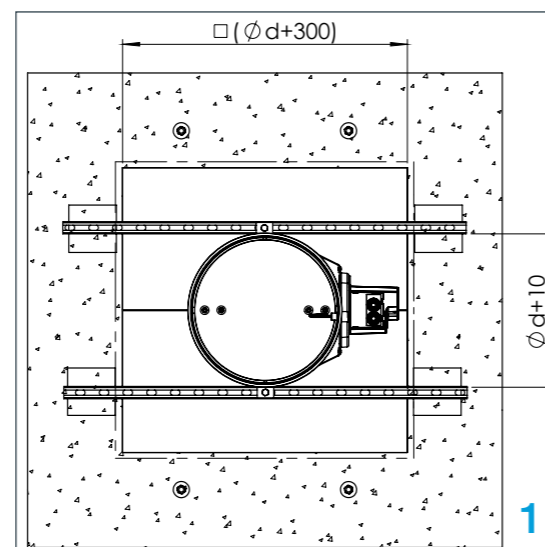

Suspension for rigid ceiling installation

Suspension systems are required for the Fire Batt/ Weichschott installation of the fire damper with mineral wool in ceiling slabs. Fire dampers can be suspended from solid ceiling slabs using adequately sized threaded rods. Load the suspension system only with the weight of the fire damper. Ducts must be suspended separately.



INSTALLATION

1. Suspension strut should be connected with drop rods (8/10 mm) to the ceiling slab above. It is used to support the damper and ease the installation.
2. If using L profile fixation, support steel C profile with 50 mm high piece of aerated concrete or similar rigid material. Not necessary if connecting rods directly to damper.
3. Damper casing is fixed to suspended and supported steel C profiles by two self tapping screws 4,8x16 (**make sure that it doesn't interfere with damper blade**) with L profile hanger (**detail A**) fixed to steel C profiles by M8 screw and nut. Position of self-tapping screws is trough the middle of damper casing.
4. To finish the installation please follow the steps (2.-4.) from [page 32](#).

Damper blade must be closed during installation!
Test the operation of the damper blade!

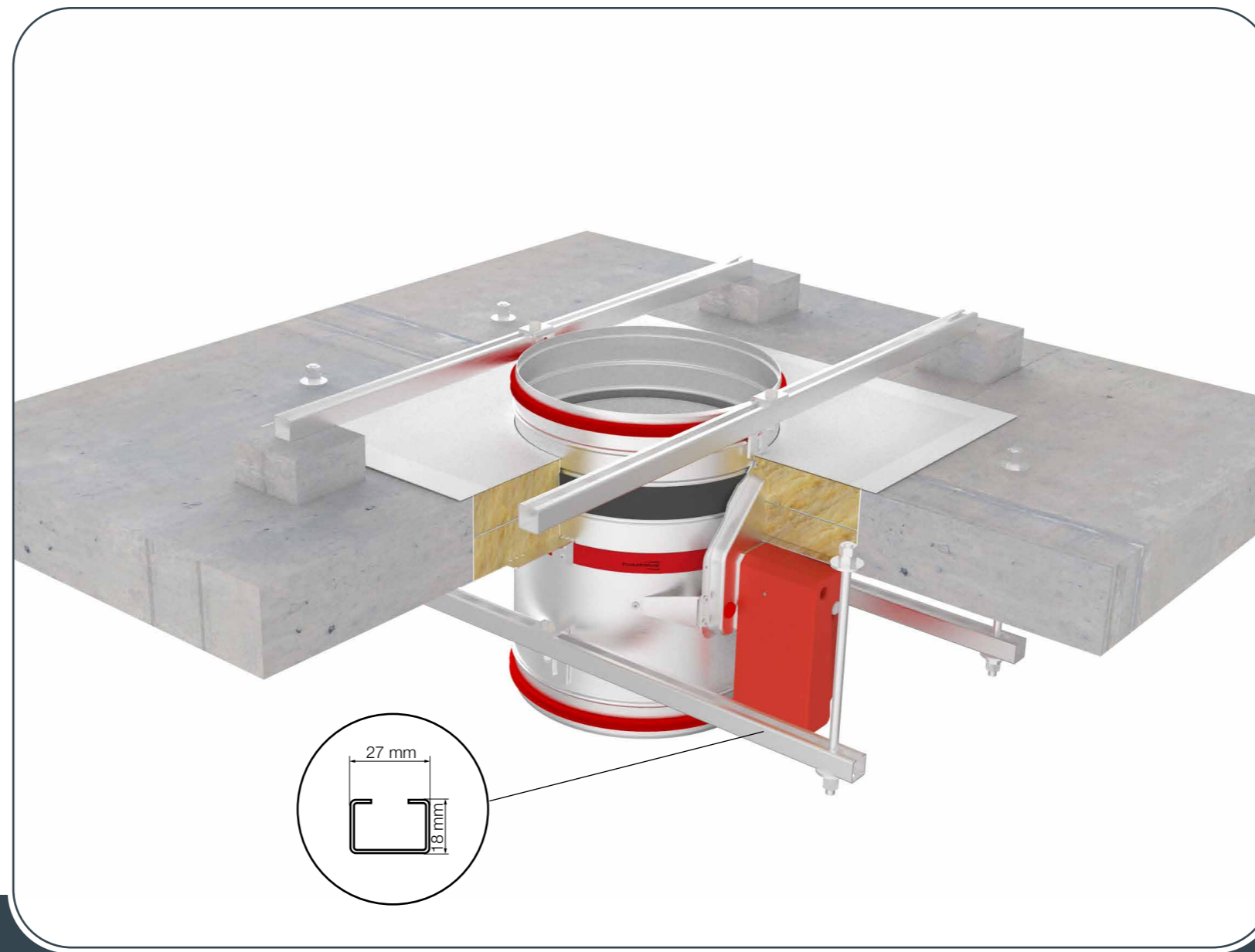

- ▼ [PRODUCT OVERVIEW](#)
- ▼ [DIMENSIONS](#)
- ▼ [INSTALLATIONS](#)
- ▼ [ACTUATORS](#)
- ▼ [ACCESSORIES](#)
- ▼ [REPLACEMENTS](#)
- ▼ [MAINTENANCE AND OPERATION](#)

Possible damper orientations



FIRE DAMPER - FDC

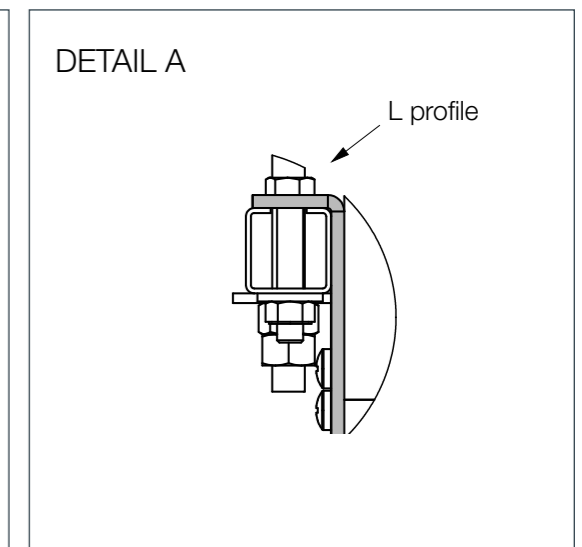
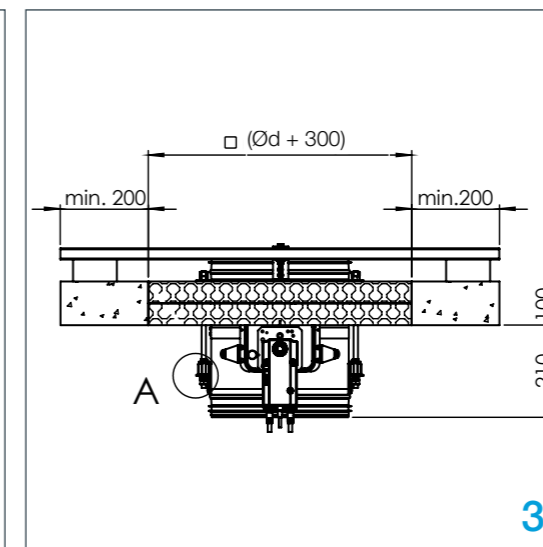
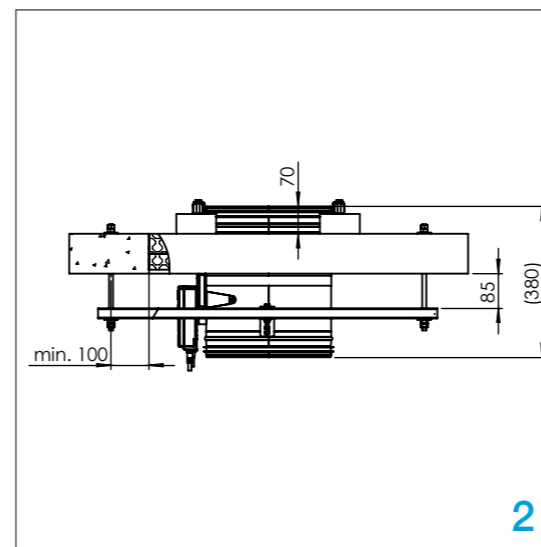
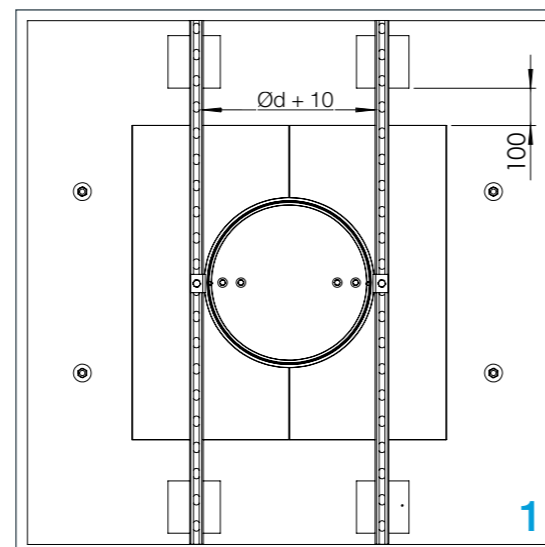

Rigid wall installation Applique installation frame

The wall is composed of concrete blocks (minimum density of 450 kg/m³) or reinforced concrete (minimum density of 2200 kg/m³) and with a minimum thickness of 100 mm.



INSTALLATION

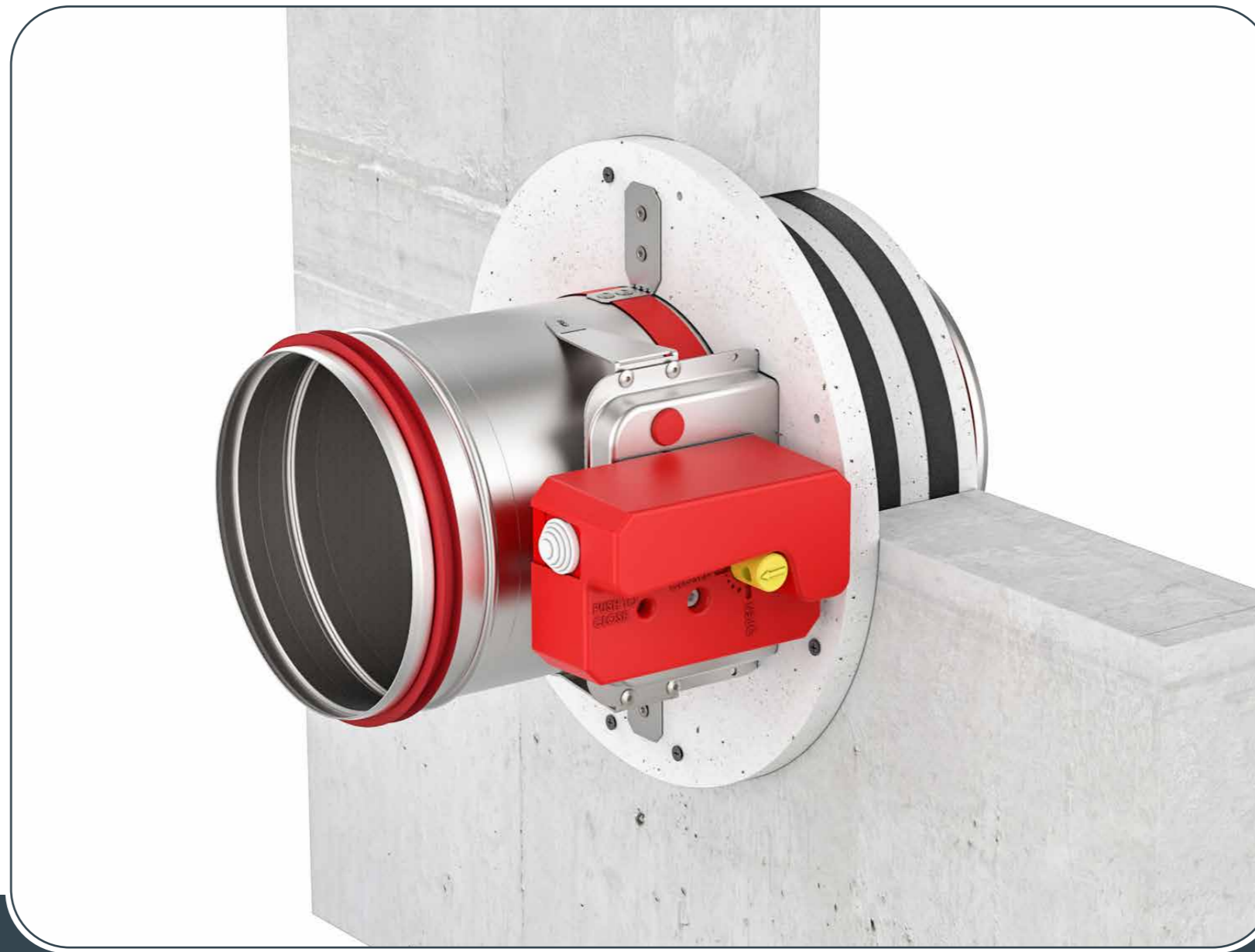

- ▼ [PRODUCT OVERVIEW](#)
- ▼ [DIMENSIONS](#)
- ▼ [INSTALLATIONS](#)
- ▼ [ACTUATORS](#)
- ▼ [ACCESSORIES](#)
- ▼ [REPLACEMENTS](#)
- ▼ [MAINTENANCE AND OPERATION](#)

Possible damper orientations



FIRE DAMPER - FDC

1. Create a wall opening according to the dimensions in the table below.
2. Insert fire damper into wall and fasten with screws (8 pcs, 4,8x60 mm).

Damper blade must be closed during installation!

Test the operation of the damper blade!

Damper diameter Ød [mm]	Wall opening dimensions	
	Applique frame diameter Ød[mm]	Wall opening [mm]
100	Ød + 105 mm	Ød + 115 mm
125-180	Ød + 95 mm	Ød + 105 mm
200-315	Ød + 80 mm	Ød + 90 mm

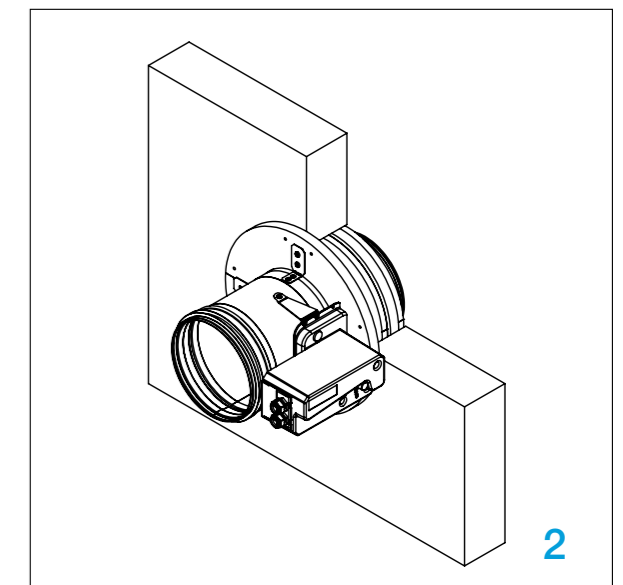
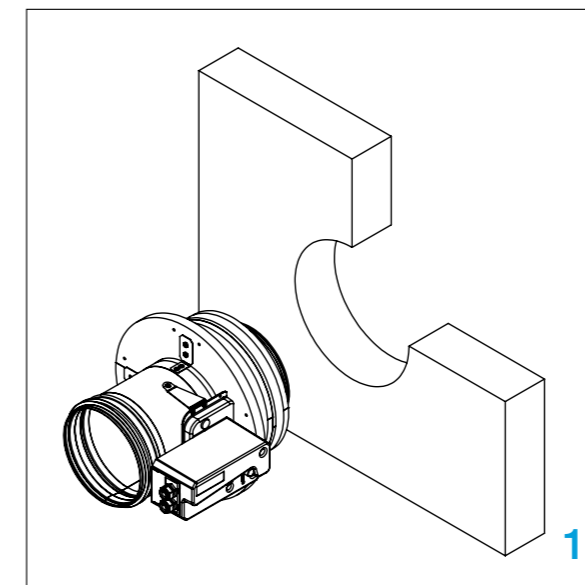

Gypsum blocks wall installation

Applique installation frame

The wall is composed of gypsum blocks (minimum density of 995 kg/m³), and with minimum thickness of 70 mm.



INSTALLATION



- ▼ [PRODUCT OVERVIEW](#)
- ▼ [DIMENSIONS](#)
- ▼ [INSTALLATIONS](#)
- ▼ [ACTUATORS](#)
- ▼ [ACCESSORIES](#)
- ▼ [REPLACEMENTS](#)
- ▼ [MAINTENANCE AND OPERATION](#)

Possible damper orientations



FIRE DAMPER - FDC

1. Create a wall opening according to the dimensions in the table below.
2. Insert fire damper into wall and fasten with screws (8 pcs, 4,8x60 mm).

Damper blade must be closed during installation!

Test the operation of the damper blade!

Damper diameter Ød [mm]	Wall opening dimensions	
	Applique frame diameter Ød[mm]	Wall opening [mm]
100	Ød + 105 mm	Ød + 115 mm
125-180	Ød + 95 mm	Ød + 105 mm
200-315	Ød + 80 mm	Ød + 90 mm

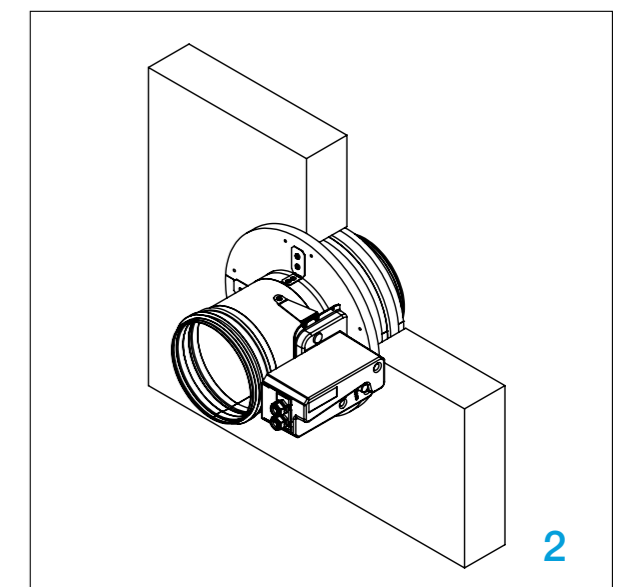
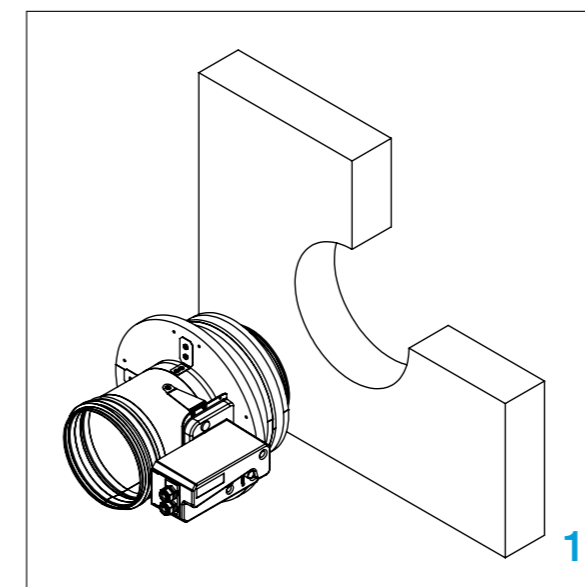

Flexible wall installation Applique installation frame

The wall is composed of 2x2 plasterboard boards, 12,5 mm thick, installed on a steel frame construction. To fulfill the classification it is **NOT** mandatory to use the mineral wool inside the wall (mineral wool with density up to 100 kg/m³ can be used). The minimum thickness of the wall is 100 mm.



INSTALLATION



- ▼ [PRODUCT OVERVIEW](#)
- ▼ [DIMENSIONS](#)
- ▼ [INSTALLATIONS](#)
- ▼ [ACTUATORS](#)
- ▼ [ACCESSORIES](#)
- ▼ [REPLACEMENTS](#)
- ▼ [MAINTENANCE AND OPERATION](#)

Possible damper orientations



FIRE DAMPER - FDC

*Create an opening according to the table below and build the subframe according to the drawing, [see page 45](#).

1. Place the fire damper in the opening.

Damper blade must be closed during installation!

2. Fasten the fire damper with screws (8 pcs, 4,8x60 mm).

Test the operation of the damper blade!

Damper diameter Ød [mm]	Wall opening dimensions	
	Applique frame diameter Ød [mm]	Wall opening [mm]
100	Ød + 105 mm	Ød + 115 mm
125-180	Ød + 95 mm	Ød + 105 mm
200-315	Ød + 80 mm	Ød + 90 mm

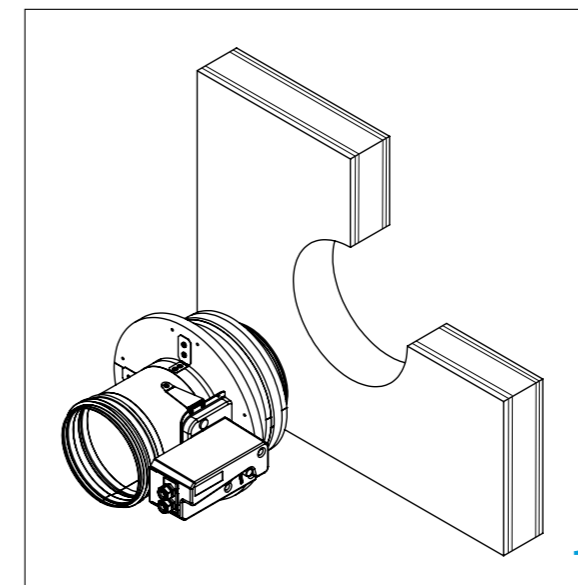

1

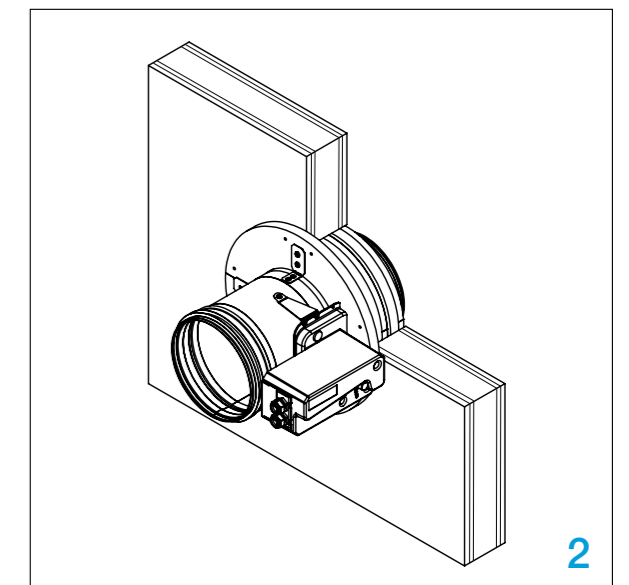

2

Rigid wall installation MF1/MF2 installation frame

The wall is composed of concrete blocks (minimum density of 450 kg/m³) or reinforced concrete (minimum density of 2200 kg/m³) and with a minimum thickness of 100 mm.



INSTALLATION



- ▼ [PRODUCT OVERVIEW](#)
- ▼ [DIMENSIONS](#)
- ▼ [INSTALLATIONS](#)
- ▼ [ACTUATORS](#)
- ▼ [ACCESSORIES](#)
- ▼ [REPLACEMENTS](#)
- ▼ [MAINTENANCE AND OPERATION](#)

Possible damper orientations



FIRE DAMPER - FDC

1. Create an opening in the wall
(FDC25- Ød +10 mm, FDC40-Ød + 25 mm).

2. Place the damper in the opening.

Damper blade must be closed during installation!

3. Fasten the fire damper with screws
FDC25- 4 pcs, 6x140 mm,
FDC40- 12 pcs, 6x140 mm.

Test the operation of the damper blade!

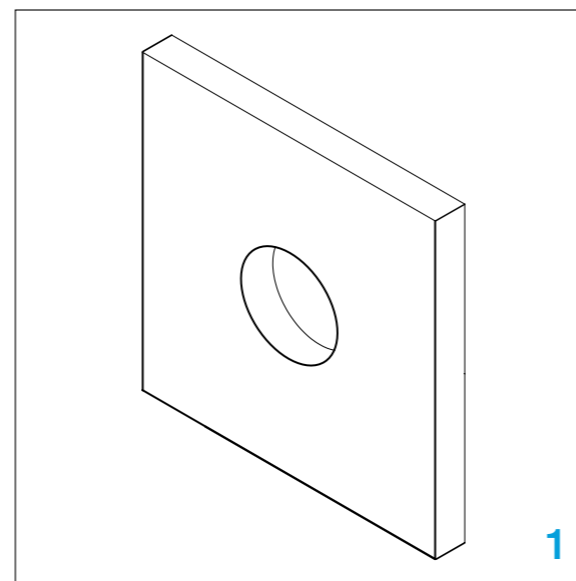

1

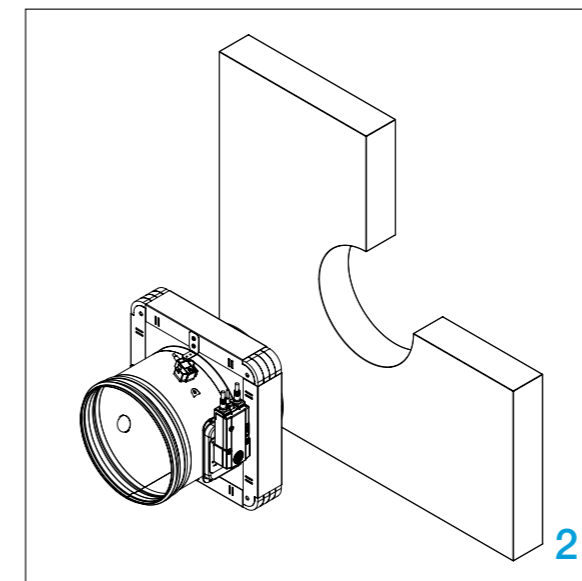

2

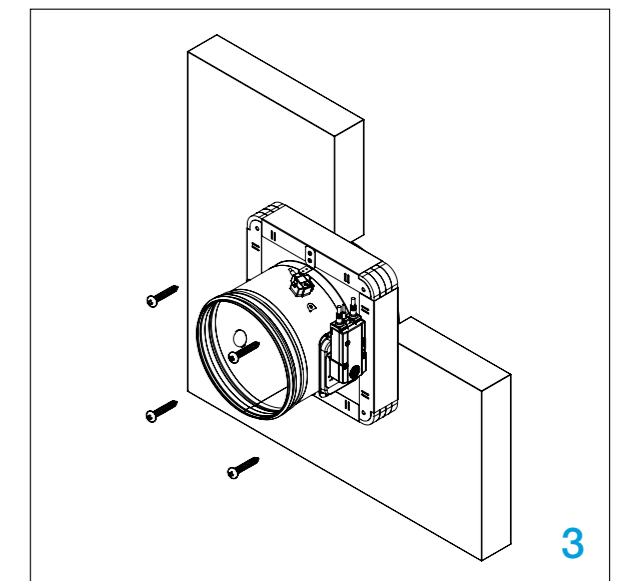

3

Gypsum blocks wall MF1/MF2 installation frame

The wall is composed of gypsum blocks (minimum density of 995 kg/m³) and with minimum thickness of 70 mm.



INSTALLATION

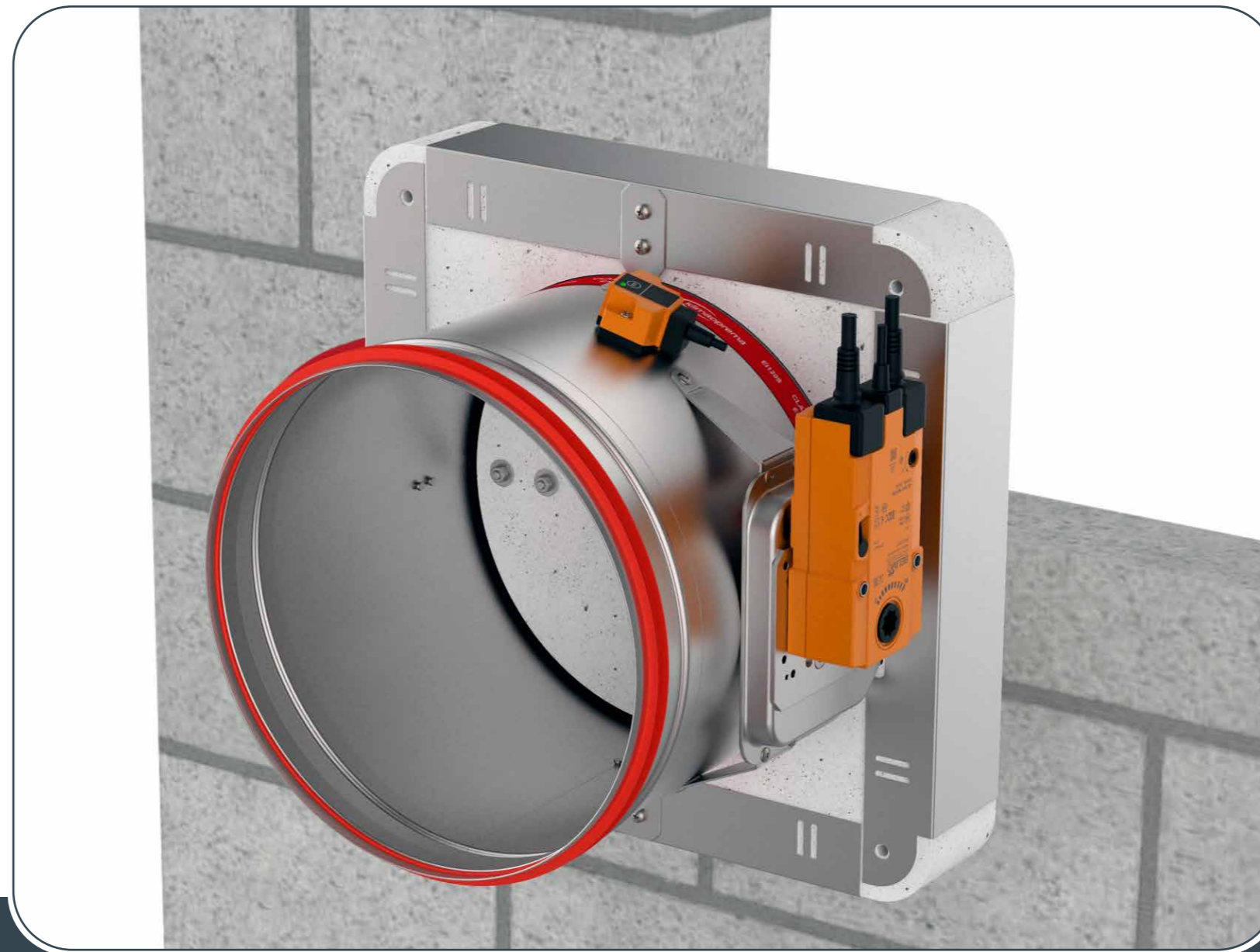

- ▼ [PRODUCT OVERVIEW](#)
- ▼ [DIMENSIONS](#)
- ▼ [INSTALLATIONS](#)
- ▼ [ACTUATORS](#)
- ▼ [ACCESSORIES](#)
- ▼ [REPLACEMENTS](#)
- ▼ [MAINTENANCE AND OPERATION](#)

Possible damper orientations



FIRE DAMPER - FDC

1. Create an opening in the wall
(FDC25- Ød +10 mm, FDC40-Ød + 25 mm).

2. Place the damper in the opening.

Damper blade must be closed during installation!

3. Fasten the fire damper with screws
FDC25- 4 pcs, 6x140 mm,
FDC40- 12 pcs, 6x140 mm.

Test the operation of the damper blade!

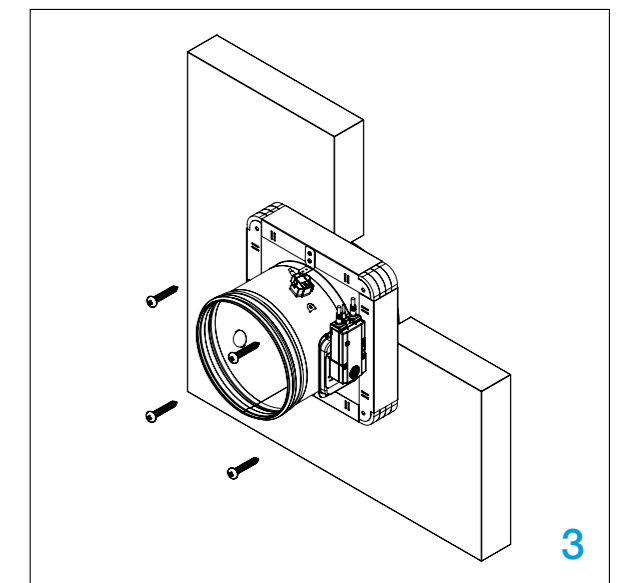
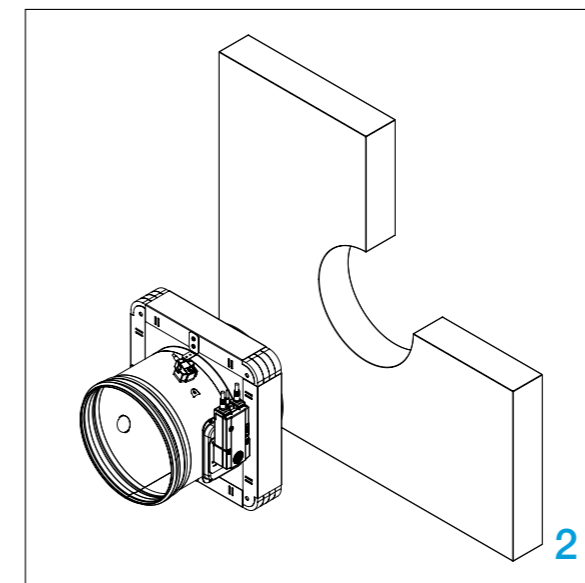
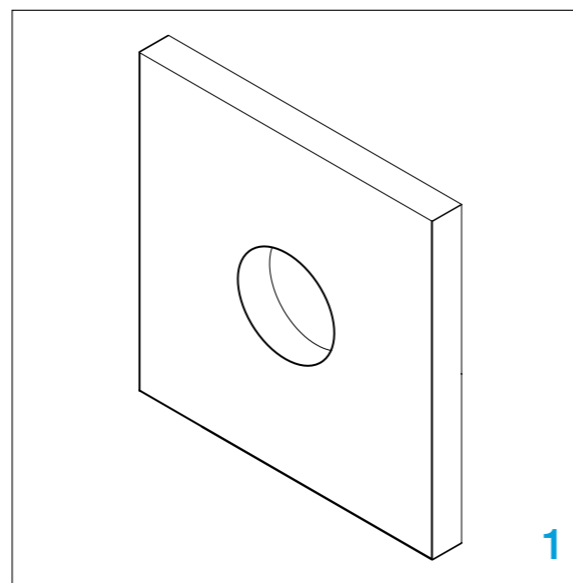

Flexible wall installation MF1/MF2 installation frame

MF1 (EI 60 (ve i↔o)S)

The wall is made out of type A (EN520) gypsum plaster boards. To fulfill the classification it is **NOT** mandatory to use the mineral wool inside the wall (mineral wool with density up to 60 kg/m³ can be used). The minimum thickness of the wall is 100 mm.

MF2 (EI 90 (ve i↔o)S)

The wall is made out of type F (EN520) gypsum plaster boards, installed on a steel frame construction. To fulfill the classification it is **NOT** mandatory to use the mineral wool inside the wall (mineral wool with density up to 100 kg/m³ can be used). The minimum thickness of the wall is 100 mm.



INSTALLATION



- ▼ [PRODUCT OVERVIEW](#)
- ▼ [DIMENSIONS](#)
- ▼ [INSTALLATIONS](#)
- ▼ [ACTUATORS](#)
- ▼ [ACCESSORIES](#)
- ▼ [REPLACEMENTS](#)
- ▼ [MAINTENANCE AND OPERATION](#)

Possible damper orientations

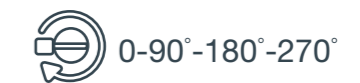

FIRE DAMPER - FDC

1. Create an opening in the wall (FDC25- Ød +10 mm, FDC40-Ød + 25 mm) and build the subframe according to the drawing, [see page 46](#).

2. Place the fire damper in the opening. **Damper blade must be closed during installation!**

3. Fasten the fire damper with screws
FDC25- 4 pcs, 6x140 mm,
FDC40- 12 pcs, 6x140 mm.

Test the operation of the damper blade!

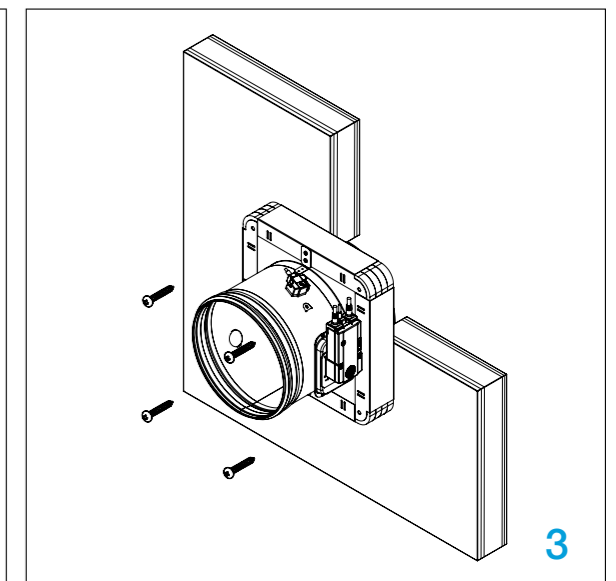
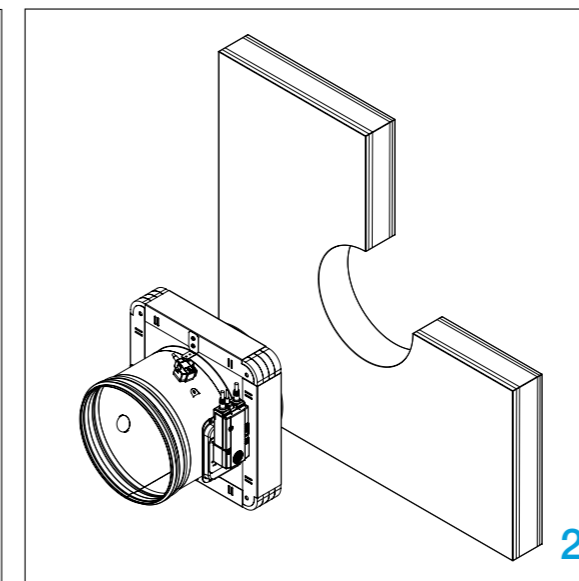
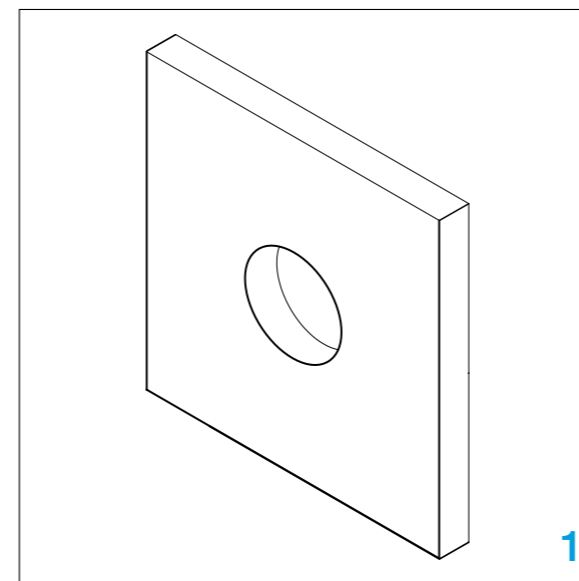

Rigid floor/ceiling installation MF1/MF2 installation frame

The floor/ceiling is composed of concrete blocks (minimum density of 450 kg/m³) or reinforced concrete (minimum density of 2200 kg/m³) and with a minimum thickness of 100 mm.



INSTALLATION

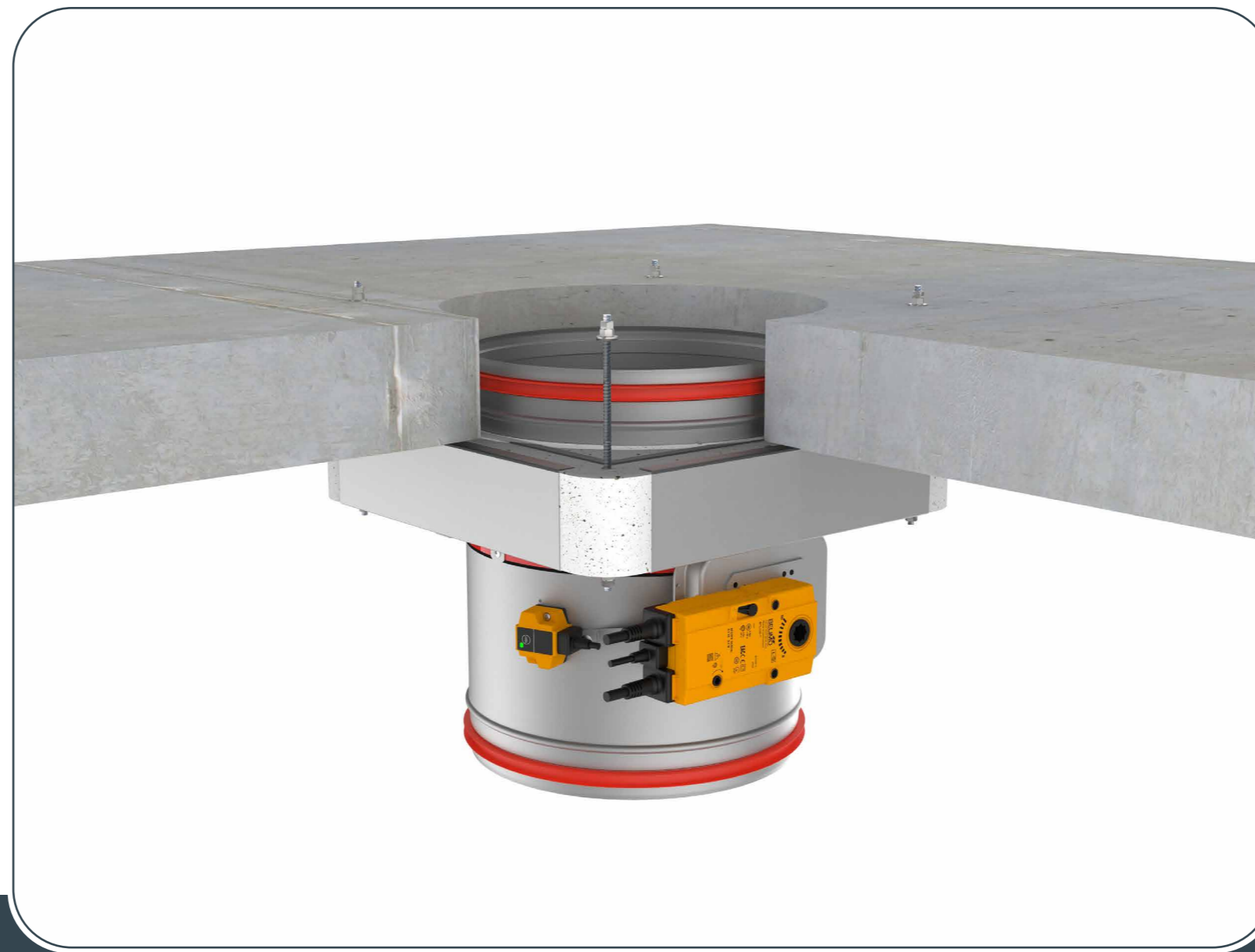

- ▼ [PRODUCT OVERVIEW](#)
- ▼ [DIMENSIONS](#)
- ▼ [INSTALLATIONS](#)
- ▼ [ACTUATORS](#)
- ▼ [ACCESSORIES](#)
- ▼ [REPLACEMENTS](#)
- ▼ [MAINTENANCE AND OPERATION](#)

Possible damper orientations



FIRE DAMPER - FDC

1. Create an opening in the floor/ceiling (FDC25- Ød +10 mm, FDC40-Ød + 25 mm). Insert the fire damper into the opening and mark the places for drilling holes.

2. Remove the fire damper and drill the marked places (8 mm).

3. Mount 4/12 sets of pre-cut threaded rods, washer, nut and counternut on one side. Place pre-assembled threaded rods in holes in floor/ceiling, and place the damper in the opening. Tighten the tightening sets from opposite side with washer, nut and counternut.

Damper blade must be closed during installation!

Test the operation of the damper blade!

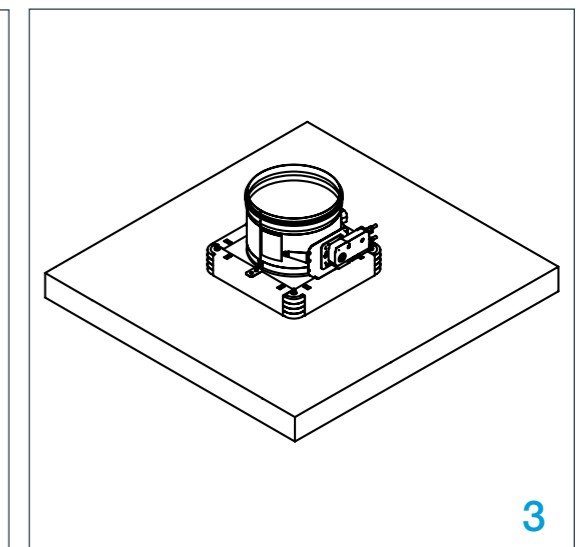
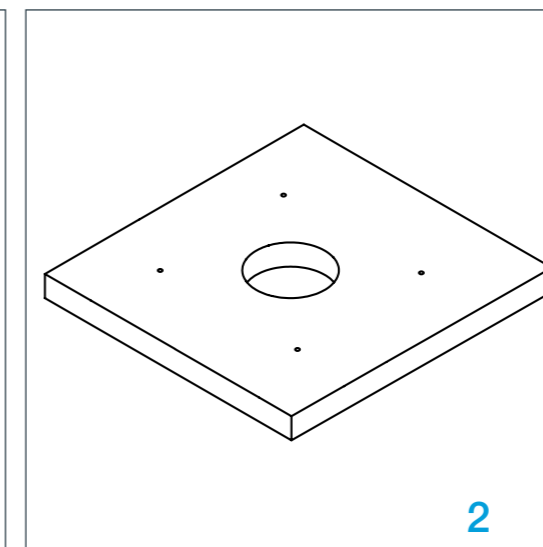
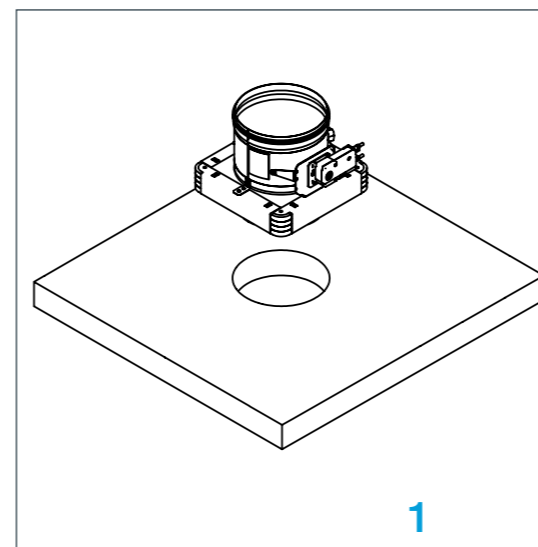

Shaft wall installation

MF2 installation frame

The wall is composed of 1x2 plasterboard boards, 12,5 mm / 20 mm thick, installed on a steel frame construction.

FDC25/FDC40 MF2 (EI 60 (ve i↔o)S) - 12,5 mm - GKF/Piano

FDC25/FDC40 MF2 (EI 90 (ve i↔o)S) - 20 mm - Fireboard



- ▼ [PRODUCT OVERVIEW](#)
- ▼ [DIMENSIONS](#)
- ▼ [INSTALLATIONS](#)
- ▼ [ACTUATORS](#)
- ▼ [ACCESSORIES](#)
- ▼ [REPLACEMENTS](#)
- ▼ [MAINTENANCE AND OPERATION](#)

Possible damper orientations



INSTALLATION

FIRE DAMPER - FDC

1. For fire dampers $\varnothing d < 625$ mm, make a steel subframe according to drawing (1). For fire dampers $\varnothing d > 625$ mm, make a steel subframe according to drawing (2). For installation in shaft walls without metal studs, make a steel subframe according to drawing (3).

2. Place the fire damper in the opening. **Damper blade must be closed during installation!**

3. Insert fire damper into wall and fasten with screws (12pcs, 6x160 mm).

Test the operation of the damper blade!

* Dimension G depending of the damper type is:
G=10 mm for FDC25
G=25 mm for FDC40

FDC-MF2 Fire damper ($\varnothing d < 625$ mm) installation in 75/90 mm shaft wall with metal studs

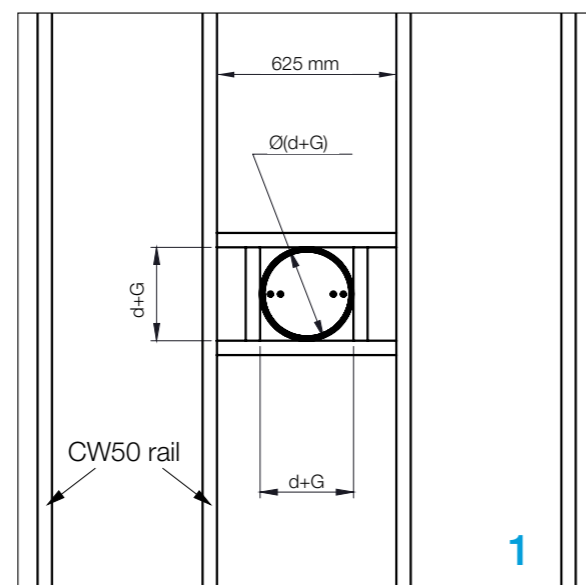

FDC-MF2 Fire damper ($\varnothing d > 625$ mm) installation in 75/90 mm shaft wall with metal studs

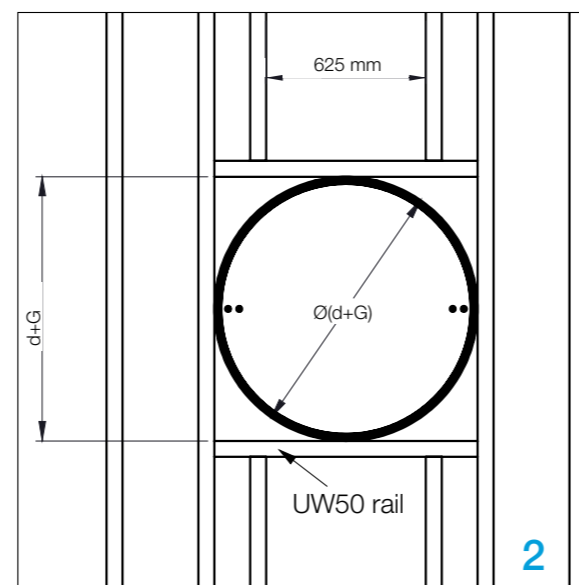

FDC-MF2 Fire damper installation in 90 mm shaft wall without metal studs (maximum wall width 2000 mm)

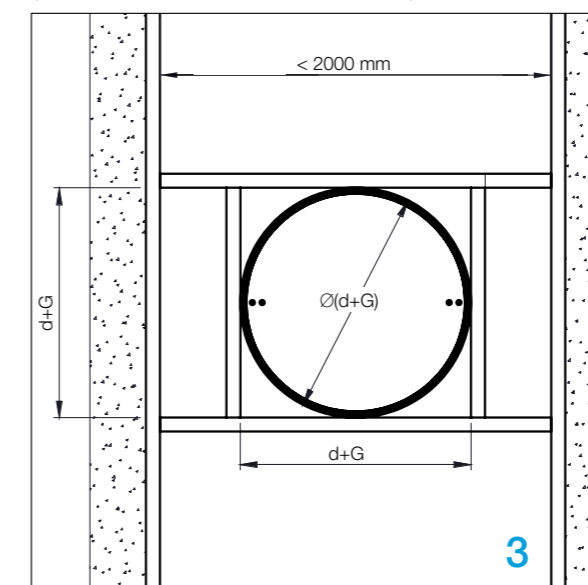

FDC25, FDC40 - side cross section

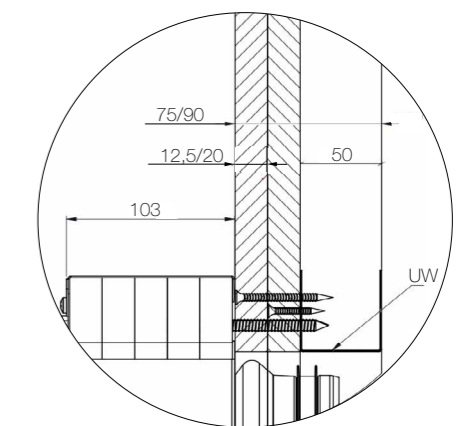

Installation remote from flexible/rigid wall FDC 25

Flexible wall: The wall is composed of 2x2 plasterboard boards, 12,5 mm thick, installed on a steel frame construction. To fulfill the classification it is **NOT** mandatory to use the mineral wool inside the wall (mineral wool with density up to 115 kg/m³ can be used). The minimum thickness of the wall is 100 mm.

Rigid wall: The wall is composed of concrete blocks (minimum density of 450 kg/m³) or reinforced concrete (minimum density of 2200 kg/m³) and with a minimum thickness of 100 mm.

[Technical drawing FDC 25](#)



INSTALLATION

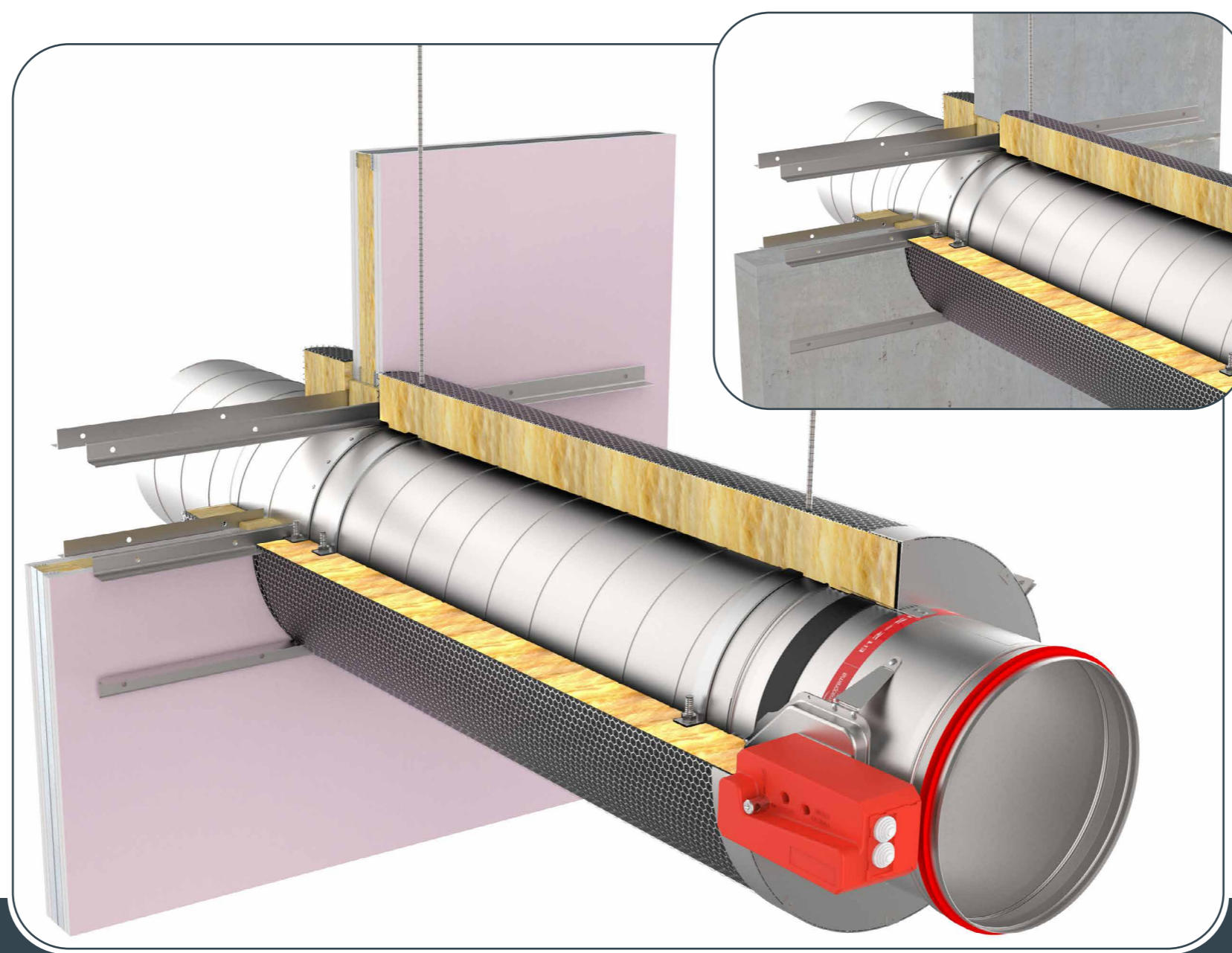

- ▼ [PRODUCT OVERVIEW](#)
- ▼ [DIMENSIONS](#)
- ▼ [INSTALLATIONS](#)
- ▼ [ACTUATORS](#)
- ▼ [ACCESSORIES](#)
- ▼ [REPLACEMENTS](#)
- ▼ [MAINTENANCE AND OPERATION](#)

Possible damper orientations



FIRE DAMPER - FDC

1. Place the damper in an opening according to the picture. Place ventilation duct trough wall (thickness of threaded rod for suspension should be M10)

2. Install fire damper and secure it with self-tapping screws 4,2x9,5 to duct (every 300 mm max). Fill space between duct and wall with mineral wool (Isover U protect Wired Mat Alu 1, min. 80 mm thickness). Additionally paint wool with Isover BSF in thickness of 2 mm on both sides.

3. Close installation with L profiles 30x30x3 mm. Additionally fix profiles to duct with self-tapping screws, and screw them to wall with 4,5x50 screws with 200 mm distance between them. On connection wool-wall apply glue Isover BSK in thickness of 2 mm. Repeat the same procedure on the other side. Place the wool on ventilation duct in length of 80 mm

4. Place steel protection on place where insulation on damper ends (80x80 mm, 1 mm thick metal sheet cover)

Damper blade must be closed during installation!

***Use MWC accessories kit for installation!**

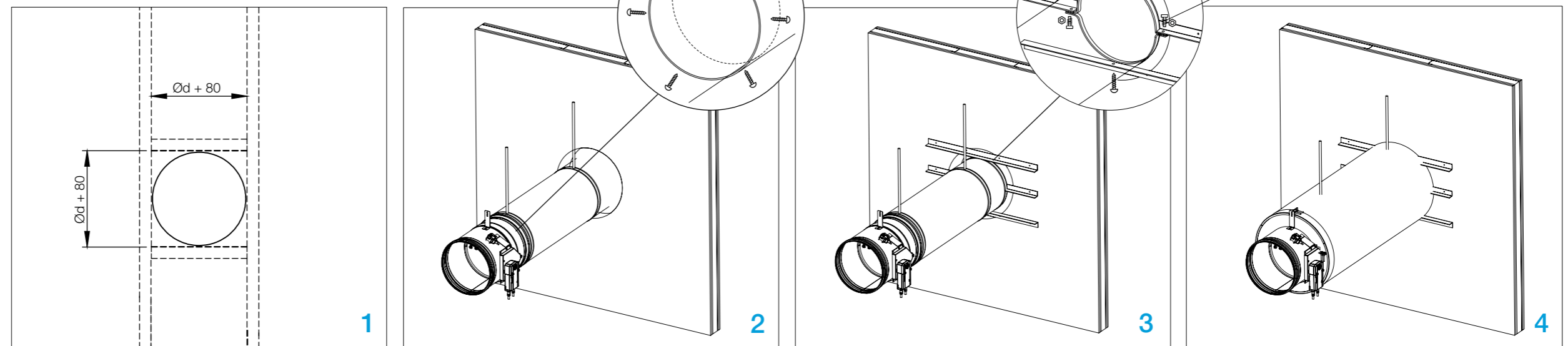

Installation remote from flexible/rigid wall FDC 40

Flexible wall: The wall is composed of 2x2 plasterboard boards, 12,5 mm thick, installed on a steel frame construction. To fulfill the classification it is **NOT** mandatory to use the mineral wool inside the wall (mineral wool with density up to 60 kg/m³ can be used). The minimum thickness of the wall is 100 mm.

Rigid wall: The wall is composed of concrete blocks (minimum density of 450 kg/m³) or reinforced concrete (minimum density of 2200 kg/m³) and with a minimum thickness of 100 mm.

[Technical drawing FDC 40](#)

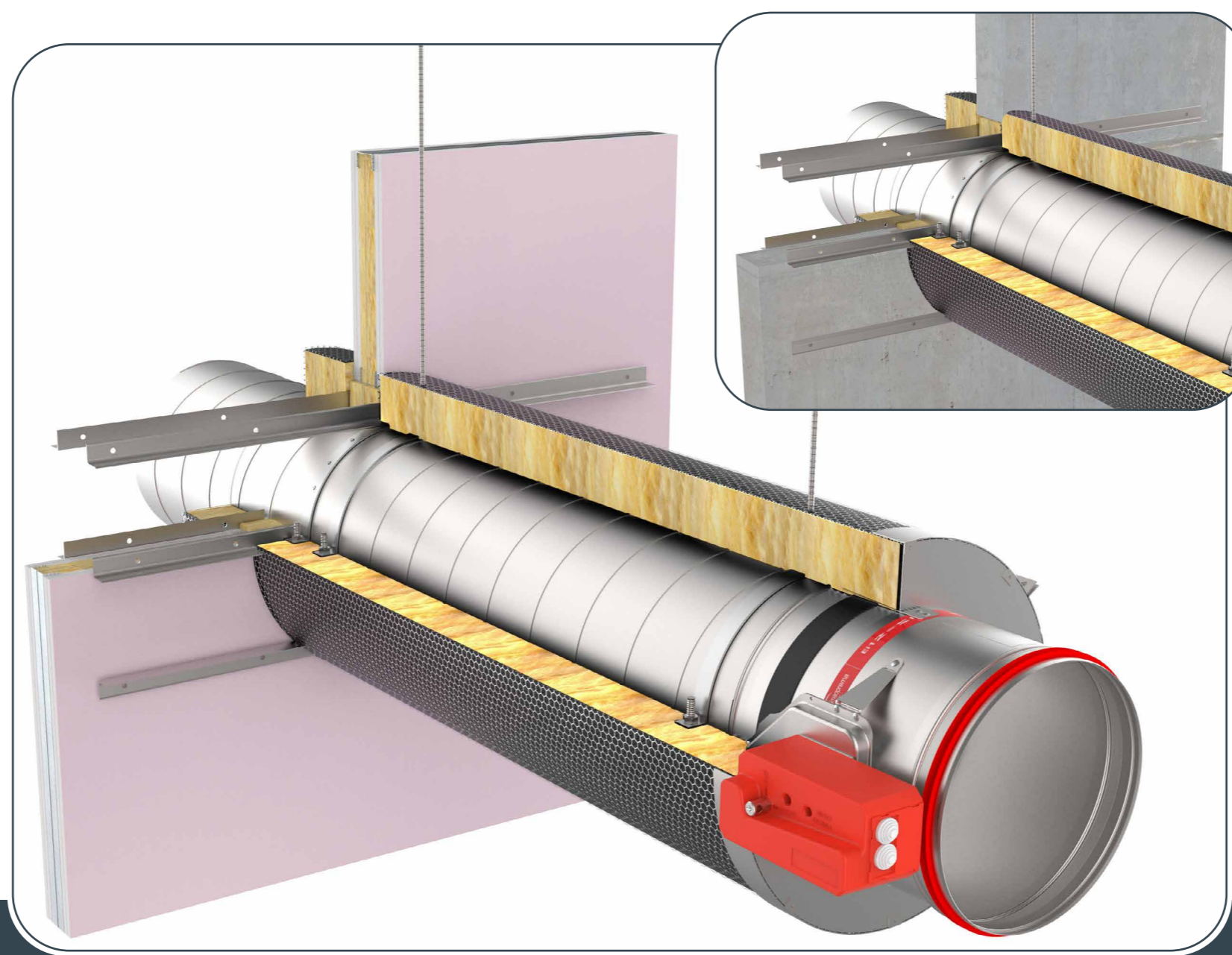

- ▼ [PRODUCT OVERVIEW](#)
- ▼ [DIMENSIONS](#)
- ▼ [INSTALLATIONS](#)
- ▼ [ACTUATORS](#)
- ▼ [ACCESSORIES](#)
- ▼ [REPLACEMENTS](#)
- ▼ [MAINTENANCE AND OPERATION](#)

Possible damper orientations



INSTALLATION

FIRE DAMPER - FDC

1. Place the damper in an opening according to the picture. Place ventilation duct trough wall (thickness of threaded rod for suspension should be M12)

2. Install fire damper and secure it with self-tapping screws 4,3x10 to duct (every 300 mm max). Fill space between duct and wall with mineral wool (Isover U protect Wired Mat Alu 1, min. 80 mm thickness). Additionally paint wool with Isover BSF in thickness of 2 mm on both sides.

3. Close installation with L profiles 30x30x3 mm. Additionally fix profiles to duct with self-tapping screws, and screw them to wall with 4,5x50 screws with 200 mm distance between them. On connection wool-wall apply glue Isover BSK in thickness of 2 mm. Repeat the same procedure on the other side. Place the wool on ventilation duct in length of 80 mm

4. Place steel protection on place where insulation on damper ends (80x80 mm, 1 mm thick metal sheet cover)

Damper blade must be closed during installation!
***Use MWC accessories kit for installation!**

Test the operation of the damper blade!

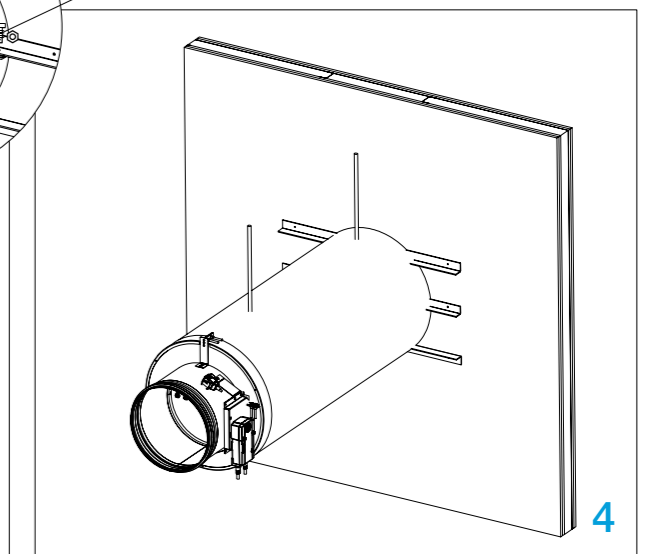
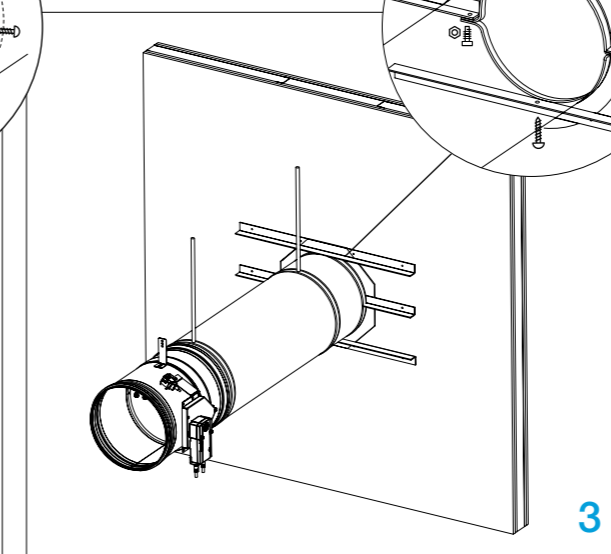
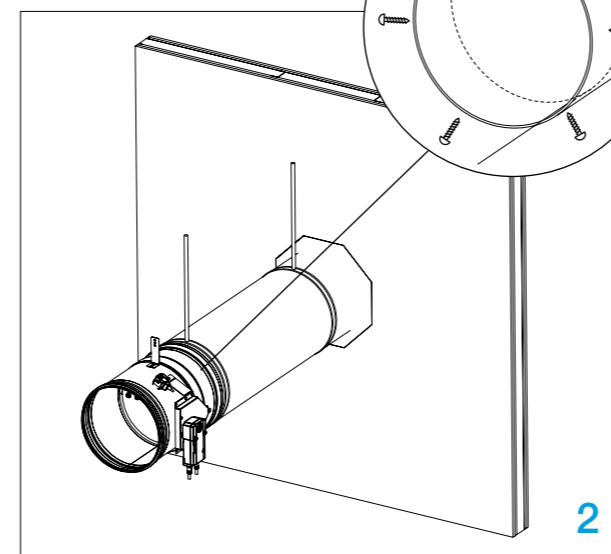
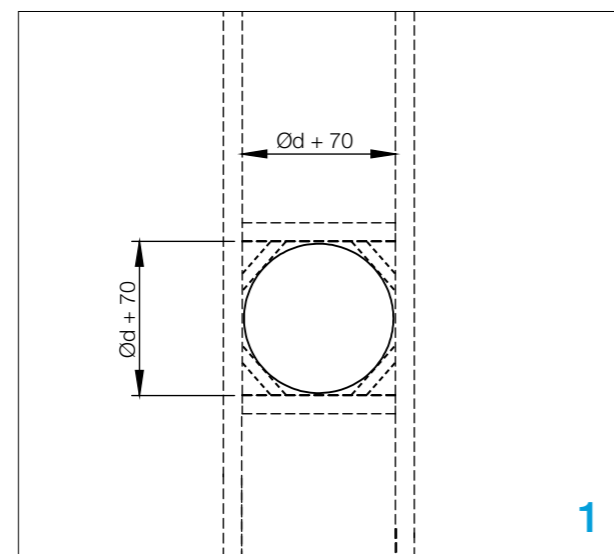

Minimal installation distances

- Material in width of supporting constructions compliant with the classification from [DOP](#)
- *Coated mineral wool 240 mm wide (140 kg/m³) only in case of weichschott/firebatt

Damper blade must be closed during installation!

Weichschott/Firebatt - Mineral wool

1*. Prepare opening in the wall according to the installation type. (Weichschott/Firebatt installation- build the subframe according to the drawing, [see page 40](#)).

Mortar - Gypsum blocks

1. Prepare opening in the wall according to the [page 14](#). Fire damper can be installed with minimal distance of 30 mm between wall/ceiling and 30 mm from other dampers.

2. Insert the fire dampers into the wall and fill the space between the dampers and between dampers and wall with material specified in DOP.

*3. In case of weichschott/firebatt installation fill the space between the dampers and between the dampers and ceiling with coated mineral wool up to flanges.

4. Complete the installation according to the DOP. Mineral wool and damper casing must be coated with 2 mm thick fire protection coating. Damper casing should be coated up to profile protrusions.

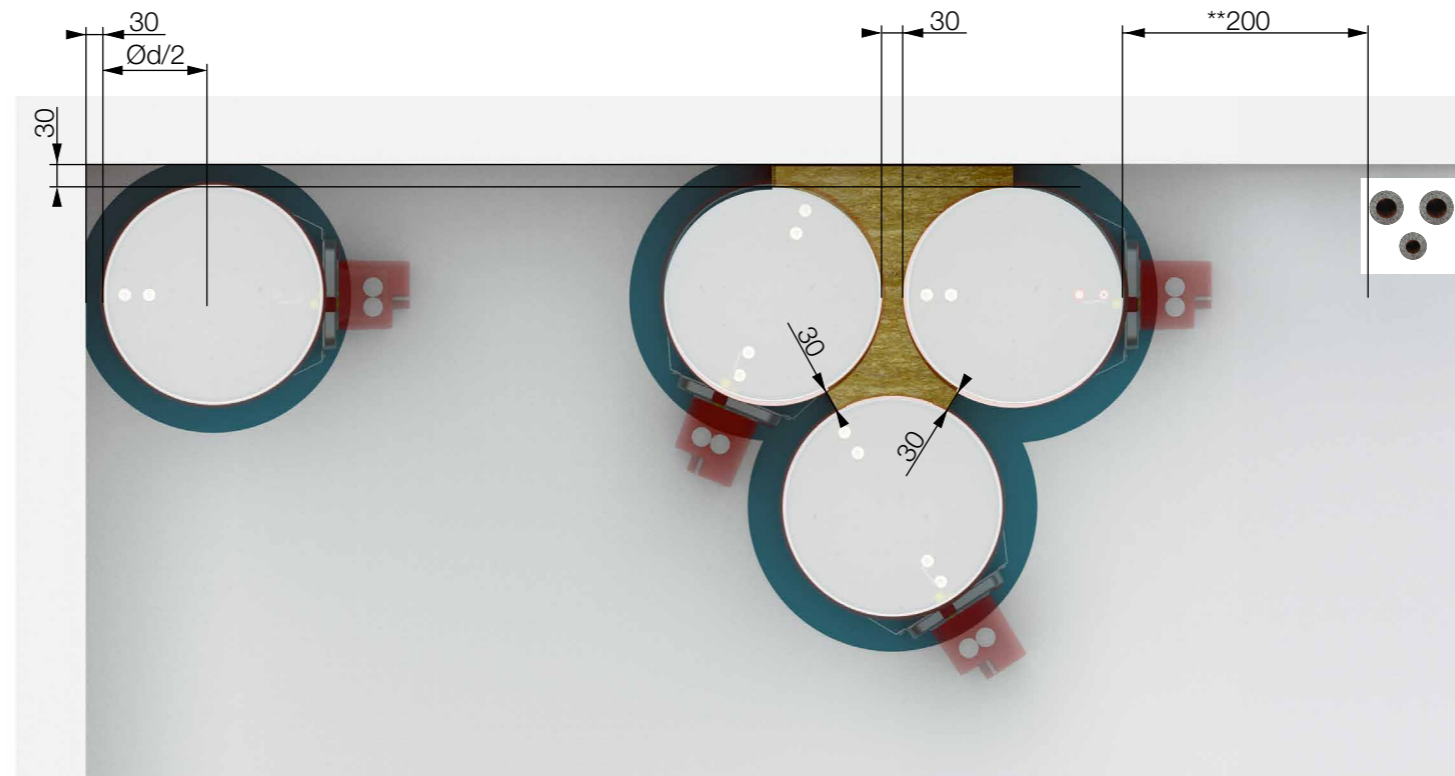

*Minimal distances from another damper or wall/ceiling.

** Minimal distances from any other penetration through the wall.

- ▼ [PRODUCT OVERVIEW](#)
- ▼ [DIMENSIONS](#)
- ▼ [INSTALLATIONS](#)
- ▼ [ACTUATORS](#)
- ▼ [ACCESSORIES](#)
- ▼ [REPLACEMENTS](#)
- ▼ [MAINTENANCE AND OPERATION](#)



FIRE DAMPER - FDC

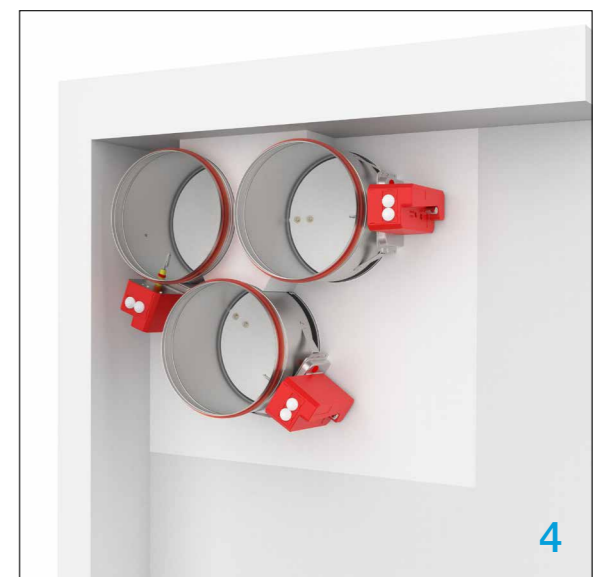
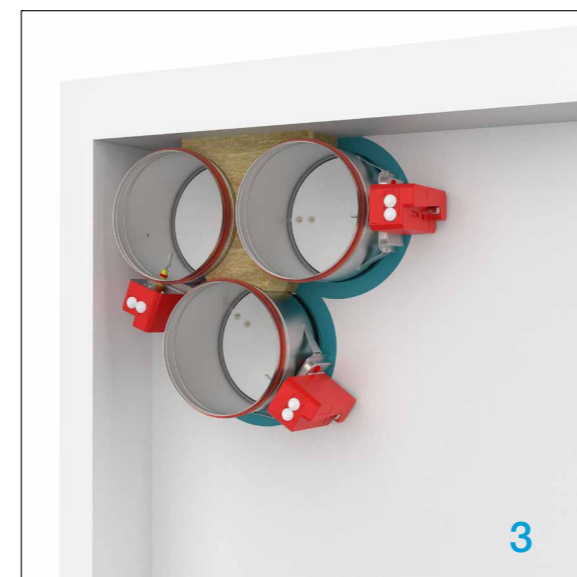
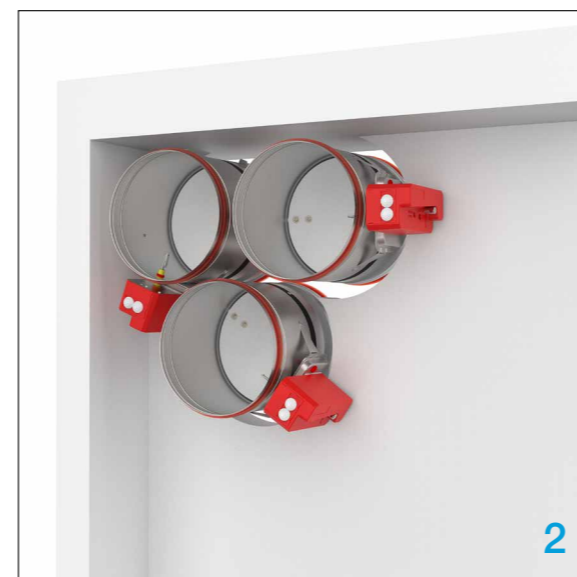
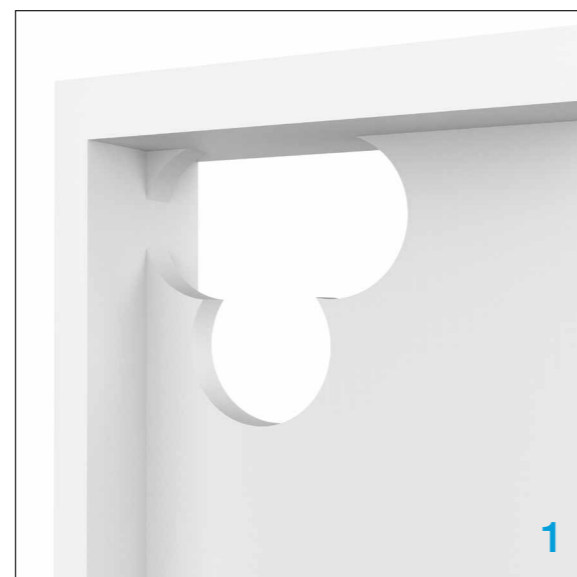
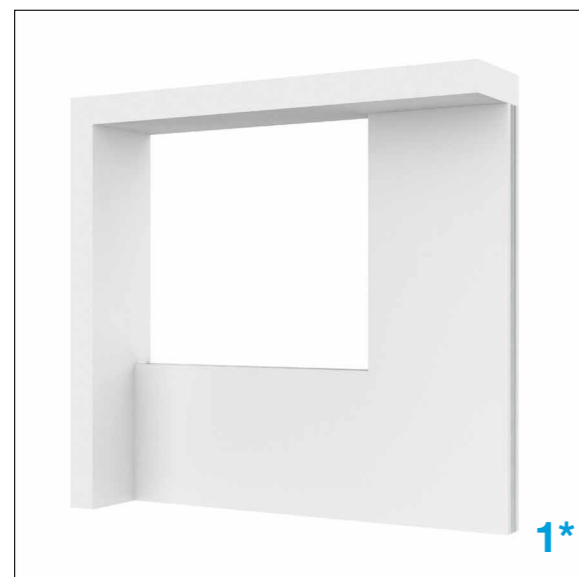

Flexible wall subframe

When installing the fire dampers in the flexible walls it is necessary to make a metal subframe onto which the damper will be fixed with screws. Subframe should be prepared according to the drawings below.

FDC25

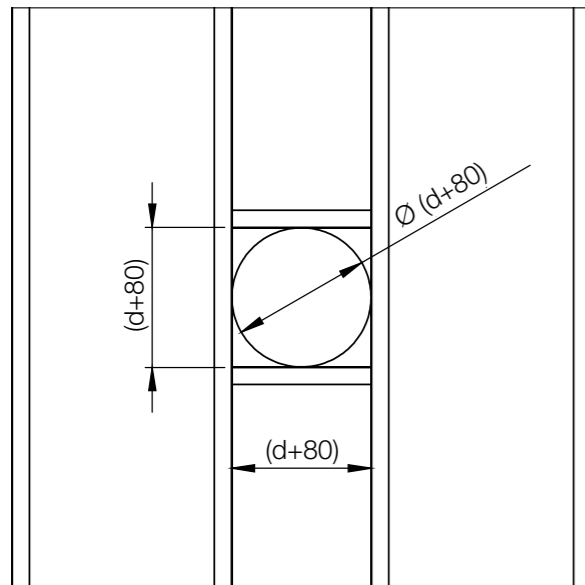

FDC40

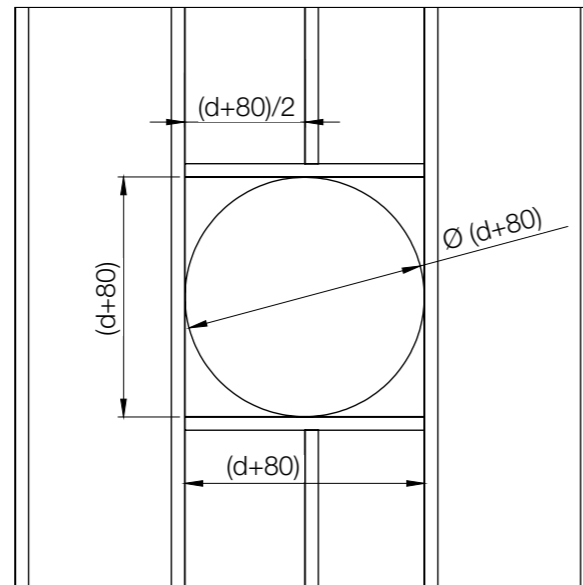

FDC25-MF1/MF2

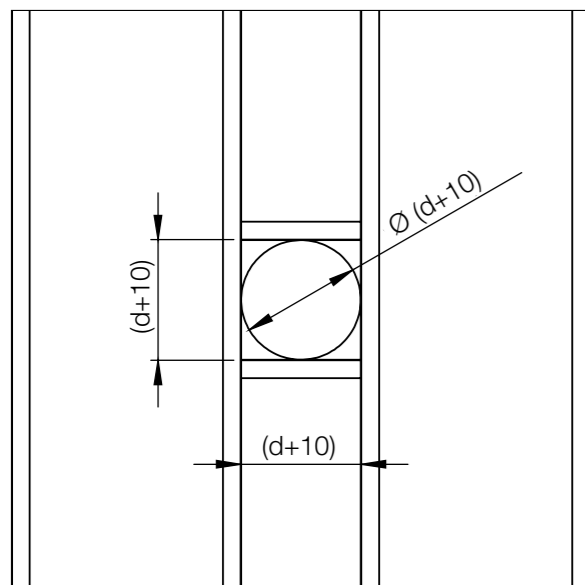

FDC40-MF2

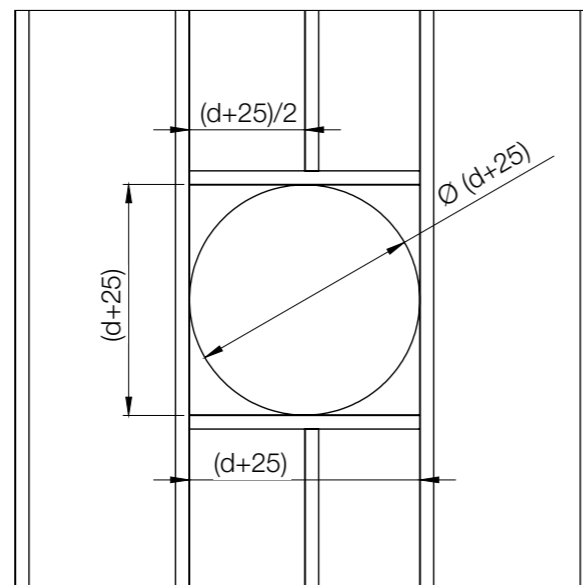

- ▼ [PRODUCT OVERVIEW](#)
- ▼ [DIMENSIONS](#)
- ▼ [INSTALLATIONS](#)
- ▼ [ACTUATORS](#)
- ▼ [ACCESSORIES](#)
- ▼ [REPLACEMENTS](#)
- ▼ [MAINTENANCE AND OPERATION](#)



FIRE DAMPER - FDC

MANUAL ACTUATORS R, R-S

Manual operating mechanism, optionally with end switches (R-S). In case of fire, the fire damper closes automatically.

Damper closing can be initiated either by thermal fuse melting, or by manual activation on the operating mechanism. Upon closure, damper blade is locked in closed position and can only be opened manually. Thermal fuse melting point is 72 °C.



R25
(up to d315)



R40
(d355 up to d800)

- ▼ [PRODUCT OVERVIEW](#)
- ▼ [DIMENSIONS](#)
- ▼ [INSTALLATIONS](#)
- ▼ [ACTUATORS](#)
- ▼ [ACCESSORIES](#)
- ▼ [REPLACEMENTS](#)
- ▼ [MAINTENANCE AND OPERATION](#)

R25

R25 manual actuator is installed on FDC25 fire dampers up to size d315. It is available in version with (R-S) and without (R) end switches. End switches and thermal fuse are easily replaceable and available as service parts. To upgrade to EMS, upgrade of R25 to R40 is required.

R40

R40 manual actuator is installed on FDC40 fire dampers up to size d800. It is available in version with (R-S) and without (R) end switches. In case remote activation is needed, R40 actuator is easily upgradeable to electromagnetic EMS-S actuator with installation of the electromagnet. End switches, thermal fuse and electromagnet are easily replaceable and available as service parts.

Technical specifications

Nominal voltage	N/A
Power	N/A
Switching capacity	1 mA...500 mA, 5VDC...48 VDC
Blade closing time	Spring: 1 second
Blade opening time	Manual
Manual activation	Release button on the casing
Degree of protection	IP 42
Ambient temperature range	min. -30 °C, max. 50 °C
Ambient humidity	95% r.h., non-condensing
Service life	Min. 30,000 cycles
Maintenance	Maintenance-free
Weight R25/R40	0,5 kg / 1.7 kg

Wiring diagram

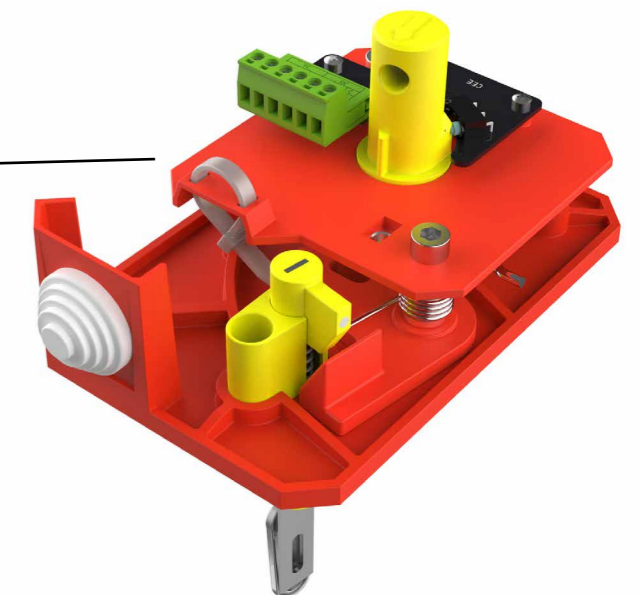
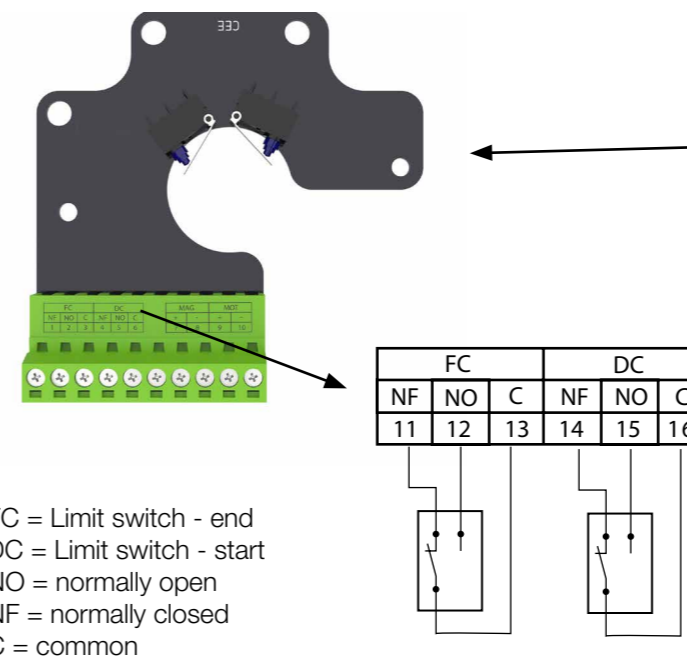

SOLENOID ACTUATOR EMS-S

Electromagnetic operating mechanism, comes with end switches as standard. In case of fire, the fire damper closes automatically. Damper closing can be initiated either by thermal fuse melting or remotely by triggering the electromagnet. Electromagnet is constantly under power and activates closing of the damper blade in case the power cuts out. Upon closure, damper blade is locked in closed position and can only be opened manually. Thermal fuse melting point is 72 °C. EMS-S mechanism is the same for FDC25/FDC40 fire dampers.



- ▼ [PRODUCT OVERVIEW](#)
- ▼ [DIMENSIONS](#)
- ▼ [INSTALLATIONS](#)
- ▼ [ACTUATORS](#)
- ▼ [ACCESSORIES](#)
- ▼ [REPLACEMENTS](#)
- ▼ [MAINTENANCE AND OPERATION](#)

Technical specifications

Nominal voltage	Solenoid: 24/ 48 VDC
Power	Dual voltage SOLENOID: Break of current: P _{nom} = 1.6 W
Switching capacity	1 mA...500 mA, 5 VDC...48 VDC
Blade closing time	Spring: 1 second
Blade opening time	Manual
Manual activation	Release button on the casing
Degree of protection	IP 42
Ambient temperature range	min. -30 °C, max. 50 °C
Ambient humidity	95% r.h., non-condensing
Service life	Min. 30,000 cycles
Maintenance	Maintenance-free
Weight	2,2 kg

Wiring diagram

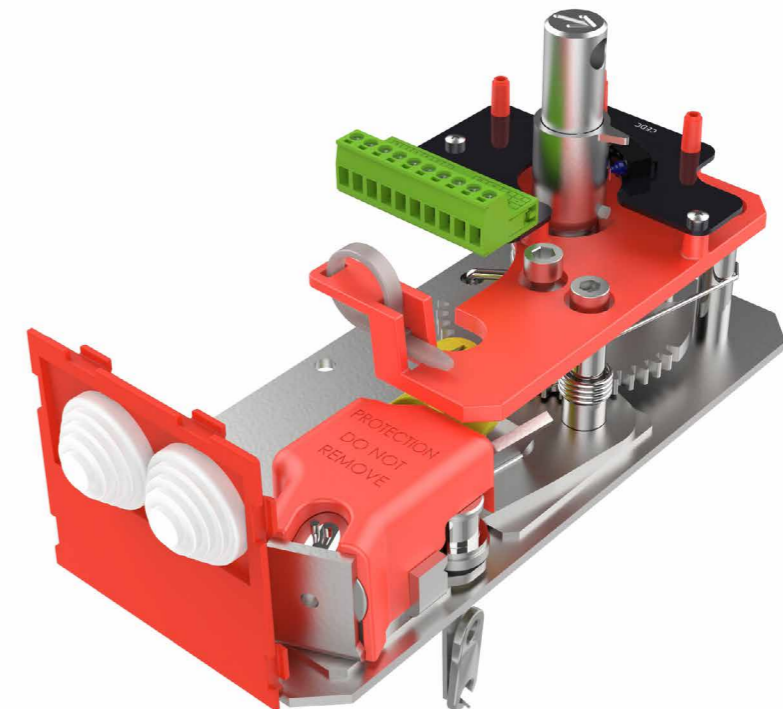
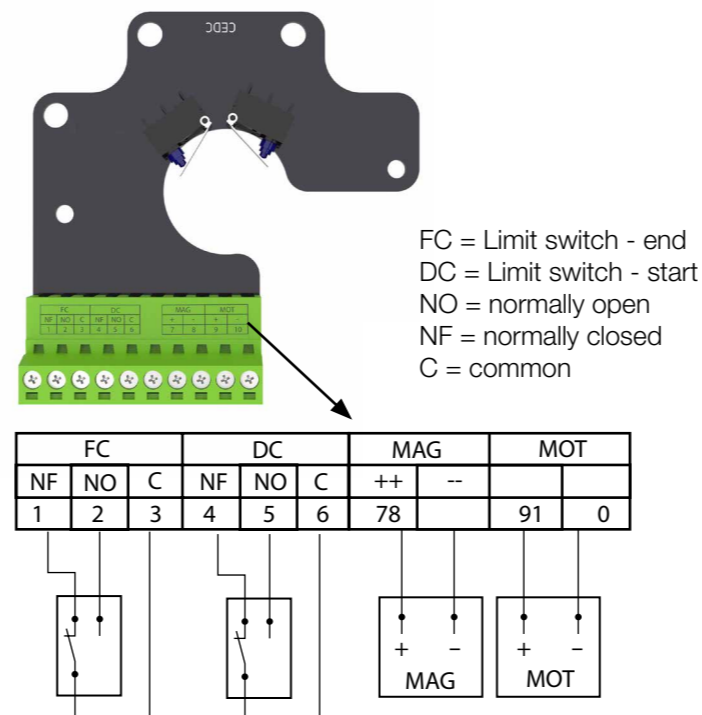

ELECTRIC ACTUATOR

M24-S, M230-S, M24-S-ST

Damper is delivered in closed position. When electric actuator is connected to the power supply, damper blade will open. When the damper reaches the end position (damper open), the electro motor will stop. Closing fire damper takes place automatically when a power failure occurs. Thermal tripping device that comes with fire damper causes power circuit break at a temperature of 72 °C (optional 95 °C). If checking is needed for proper functioning of fire damper, pushing the switch on the thermal tripping device will close damper.



- ▼ [PRODUCT OVERVIEW](#)
- ▼ [DIMENSIONS](#)
- ▼ [INSTALLATIONS](#)
- ▼ [ACTUATORS](#)
- ▼ [ACCESSORIES](#)
- ▼ [REPLACEMENTS](#)
- ▼ [MAINTENANCE AND OPERATION](#)

ACTUATORS

FIRE DAMPER - FDC

When switch on tripping device is released, the damper will open. Damper can be opened without connecting to a voltage with enclosed handle by turning it in the direction of the arrow on electric actuator (clockwise). Damper can be locked in the desired position by fast turning handle a quarter of a turn (counterclockwise) for Belimo BF, and by pulling brake on Belimo BFL and BFN.

To unlock the electro motor, turn handle clockwise for a quarter of a turn for Belimo BF, or release brake for Belimo BFL and BFN. After release, damper will be closed by return spring. When damper is opened manually, electric actuator will not move the damper into closed position in case of power failure.

Technical specifications

Type of Belimo actuator	BFL24-T	BFN24-T	BFL230-T	BFN230-T	BF24-T	BF230-T
Nominal voltage	AC/DC 24 V, 50/60 Hz	AC 24 V, 50/60 Hz	AC 230 V, 50/60 Hz	AC 230 V, 50/60 Hz	AC/DC 24 V, 50/60 Hz	AC 230 V, 50/60 Hz
opening	2,5 W	4 W	3,5 W	5 W	7 W	8.5 W
holding	0,8 W	1,4 W	1,1 W	2,1 W	2 W	3 W
for wire sizing	4 VA	6 VA	6,5 VA	10 VA	10 VA	11 VA
End switch	1 mA...3 A (0,5 A), DC 5 V... AC 250V	1 mA...3 A (0,5 A), DC 5 V... AC 250 V	1 mA...3 A (0,5 A), DC 5 V... AC 250 V	1 mA...3 A (0,5 A), DC 5 V... AC 250 V	1 mA...6 A (3 A), DC 5 V... AC 250 V	1 mA...3 A (0,5 A), DC 5 V... AC 250 V
Running time	motor < 60 s spring return ~20 s	motor < 60 s spring return ~20 s	motor < 60 s spring return ~20 s	motor < 60 s spring return ~20 s	motor < 120 s spring return ~16 s	motor < 120 s spring return ~16 s
Ambient temperature range	min. -30 °C, max. 50 °C					

Wiring diagram

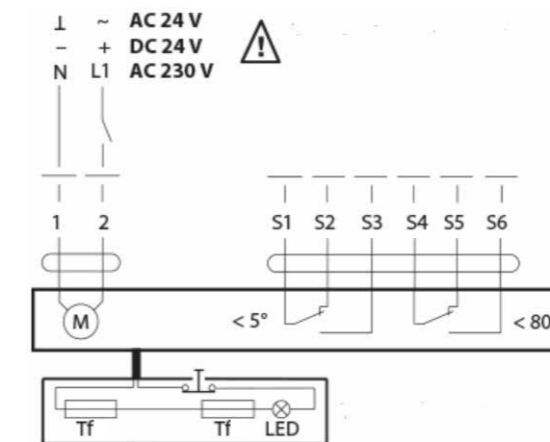

- 1 negative (direct-current) or neutral (alternating current)
- 2 positive (direct-current) or faze (alternating current)
- S1 common micro switch closed damper
- S2 normally closed micro switch closed damper
- S3 normally open micro switch closed damper
- S4 common micro switch open damper
- S5 normally closed micro switch open damper
- S6 normally open micro switch open damper
- Tf temperature sensor on the outer side of the duct (ambient temperature) max. 72 °C

ELECTRIC ACTUATOR SCHISCHEK ExMax

Damper is delivered in closed position. When electric actuator is connected to the power supply damper will open. When the damper reaches the end position(damper open), in which is it blocked, the electric actuator will stop. Closing fire damper takes place automatically when a power failure occurs. Thermal tripping device that comes with fire damper causes power circuit break at a temperature of 72 °C (inside or outside duct). If checking is needed for proper functioning of fire damper, pushing the switch on the thermal tripping device will close damper. When switch on tripping device is released, the damper will open.

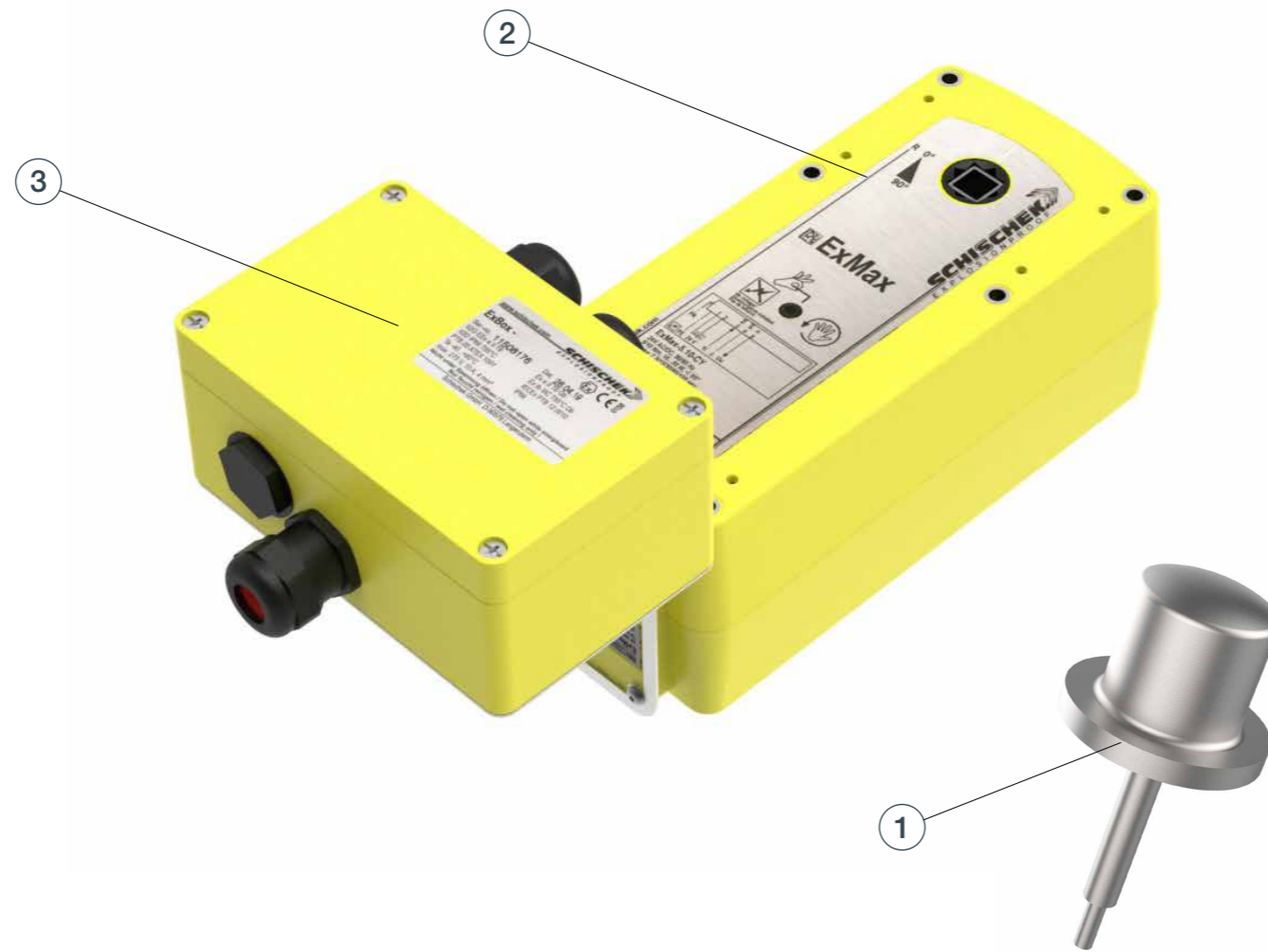

- ▼ [PRODUCT OVERVIEW](#)
- ▼ [DIMENSIONS](#)
- ▼ [INSTALLATIONS](#)
- ▼ [ACTUATORS](#)
- ▼ [ACCESSORIES](#)
- ▼ [REPLACEMENTS](#)
- ▼ [MAINTENANCE AND OPERATION](#)

Damper can be opened without connecting to a voltage with enclosed Allen key, by turning in the direction of the arrow on electric actuator (clockwise). After release of Allen key, damper will go to closed position.

- 1) [Tecnical documentation Safety temperature trigger Schischek ExPro-TT](#)
- 2) [Tecnical documentation electric actuator Schischek ExMax-5.10-BF](#)
- 3) [Tecnical documentation Ex-e terminal box ExBox-BF](#)

Technical specifications

Type	ExMax -5.10-BF
Torque	5/10 Nm
Power Supply	24-230 V AC/DC
Running time	3/15/30/60/120 s / 90°
Spring return	3 or 10s / 90°
Control mode	On-Off, 3 position
Feedback	2 x aux switches + Ex. tripping device
Ambient temperature range	min. -40 °C, max. 40 °C
Ambient humidity	0-90% r.h., non-condensing
Service life	Min. 10,000 cycles @ 10 s, min 1000 cycles @ 1s
Maintenance	Maintenance-free
Weight	3,5 kg

Wiring diagram

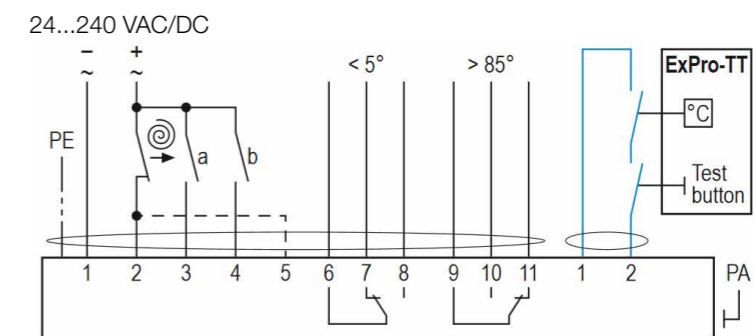

ACCESSORIES

1 GKF boards GKF boards are used in dry and wet installations as wool or mortar cover. It keeps the installation material in place and provides for better fire penetration characteristics of the whole installation. Kit dimensions- Ø + 300 mm.

2 Flexible duct connections - Flexible duct connectors are used in HVAC systems for isolation from structure-borne noise, expansion compensation and fire damper connections (total length 150mm, flexible 60mm).

3 Safety grilles - Fire damper, safety grille and, if applicable, extension piece are assembled at the factory to form a unit. The free cross sectional area of the cover grille is approx. 70%.

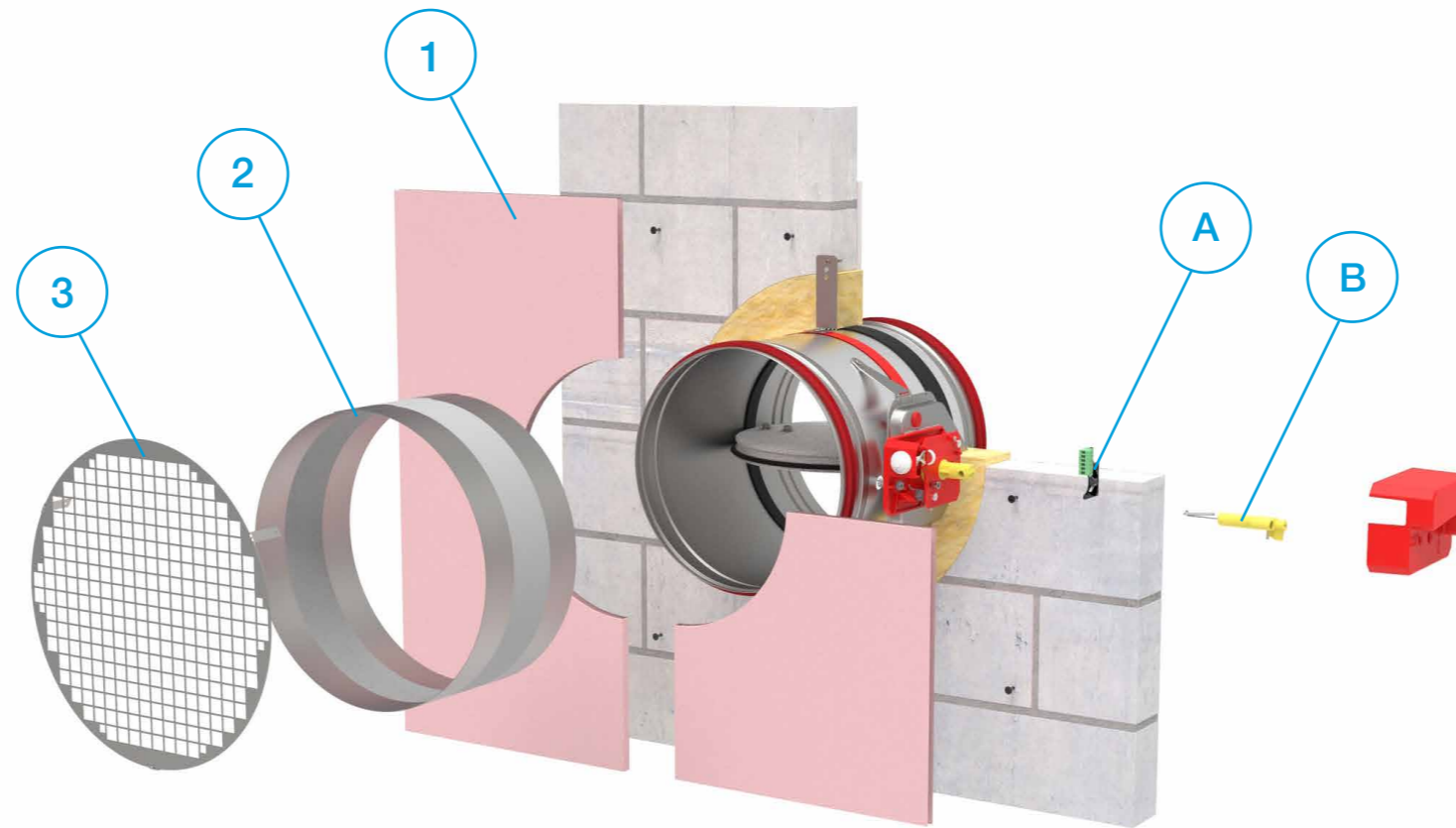

(1) Type (2) Accessories (3) Dimension

FD-A - CSP - d100

(1) **FD-A** - Accessories for round fire damper (3) d100...d800 nominal diameter of the round fire damper

(2) **CSP** - GKF boards kit (for both sides of the installation)
FLEX - Flexible duct connections (1pc)
SG1 - Safety grill on operation side
SG2 - Safety grill on installation side

- ▼ [PRODUCT OVERVIEW](#)
- ▼ [DIMENSIONS](#)
- ▼ [INSTALLATIONS](#)
- ▼ [ACTUATORS](#)
- ▼ [ACCESSORIES](#)
- ▼ [REPLACEMENTS](#)
- ▼ [MAINTENANCE AND OPERATION](#)

+ ACCESSORIES

FIRE DAMPER - FDC

For safety reasons, parts need to be changed by a trained personnel or the manufacturer.

WARNING! Install the original parts only!

- A [Double contact S kit \(CEE board\)](#) FD-A-R25S-KIT
- A*[Double contact S kit \(CEDC board\)](#) FD-A-R40S-KIT [see page 41.](#)
- B [Fuse kit](#) FD-A-THERM-72
- C [Solenoid current emission kit](#) FD-A-EMS-KIT
- D [Inspection hatch](#) FDC-A-IH (Not available with MF, App frame)
- E [Communication module bracket](#) FD-A-CMB
- F [Belimo thermal fuse 72 °C](#) FD-A-BAT72
- G [Belimo thermal fuse 95 °C](#) FD-A-BAT95
- H [Thermal fuse blanking plate](#) FD-BP-KIT
- I [Kit A](#) FDC-A-KIT-A Upgrade to electric actuator (Belimo BFL)
- J [Kit B](#) FDC-A-KIT-B Upgrade to electric actuator (Belimo BFN)
- K [Kit C](#) FD-A-KIT-C- upgrade to electric actuator (Belimo BF)
- L [R40 manual mechanism](#) FD-A-R40 [see page 40.](#)
- M [Smoke sensor](#) [see page 45.](#)
- N [Mineral wool cover \(for remote installation\)](#)- MWC [see page 38.](#)



SMOKE SENSOR ASSEMBLY FDC-SSA

Smoke sensor assembly is developed to detect smoke in ventilation ducts and combines a smoke detector and an adaptor system where both tube and housing are specially designed for optimum airflow through the smoke detector. Smoke sensor provides the signal for the fire damper which is activated when smoke is detected. Smoke sensor assembly consists of casing (length: FDC25=380 mm, FDC40=390 mm), smoke sensor and specially designed venturi pipe inside the duct.

For proper functioning of the smoke sensor (as it is physically connected as in the render above) a straight length of 5 times hydraulic diameter, in the size of the connecting duct, should be in front of the sensor. When the sensor is installed separate from the fire damper there are two conditions to be met:

- 1) Length of 5 times hydraulic diameter, in the size of the connecting duct, should be in front of the sensor.
- 2) Length of 3 times hydraulic diameter, in the size of the connecting duct, should be after the sensor.



- ▼ [PRODUCT OVERVIEW](#)
- ▼ [DIMENSIONS](#)
- ▼ [INSTALLATIONS](#)
- ▼ [ACTUATORS](#)
- ▼ [ACCESSORIES](#)
- ▼ [REPLACEMENTS](#)
- ▼ [MAINTENANCE AND OPERATION](#)

(1) Type	(2) Accessories	(3) Dimension	(4) Voltage
FDC-A	- SSA	- d100	- 24
(1) FDC-A	- Accessories for round fire damper	(3) d100...d800 nominal diameter of the round fire damper	
(2) SSA	- Smoke sensor assembly	(4) 24 - Smoke sensor 24 V 230 - Smoke sensor 230 V	

+ ACCESSORIES

FIRE DAMPER - FDC

Spare parts

- Smoke sensor FD-A-UG-5-AFR-24V
- Smoke sensor FD-A-UG-5-AFR-230V
- A Sampling tube FD-A-ST5
- B Rubber gasket FD-A-HFU204
- C Isolation extension FD-A-HFU500

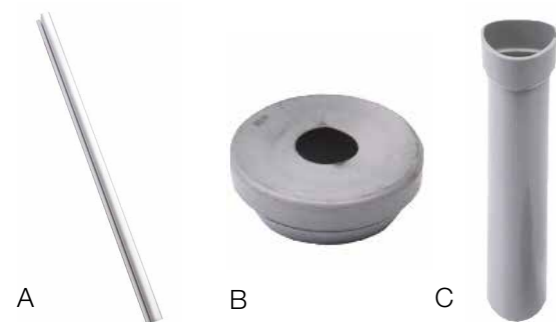

For more information, visit website:
[Technical documentation Calectro](#)

Technical specifications

	FDC-A-UG-5-AFR-24V	FDC-A-UG-5-AFR-230V
Voltage Supply	24V AC/DC -15%, +10% Not polarity sensitive	230V AC -15%, +10% Not polarity sensitive
Detector type	Optical UG-5-AFR-24V	Optical UG-5-AFR-230V
Max. power consumption	220 mA	30 mA
Operating temperature	-10°C to +55°C	
Maximum humidity	99% rH	
Duct air velocity range	1 to 20 m/s	
Approvals	VdS CE, EN-54-27	
Relay output	Potential free	
Smoke alarm relays	Two changing contacts 250V, 8A	
Service alarm	One breaking contact 250V, 5A	
System error alarm	One breaking contact 250V, 5A	
Low Flow alarm:	One breaking contact 250V, 5A	
LED on smoke detector:	Green - service alarm (contamination) Red - smoke alarm	
LED on PCB:	Green - normal operation Yellow - system error Yellow - Low-Flow	

Wiring diagram

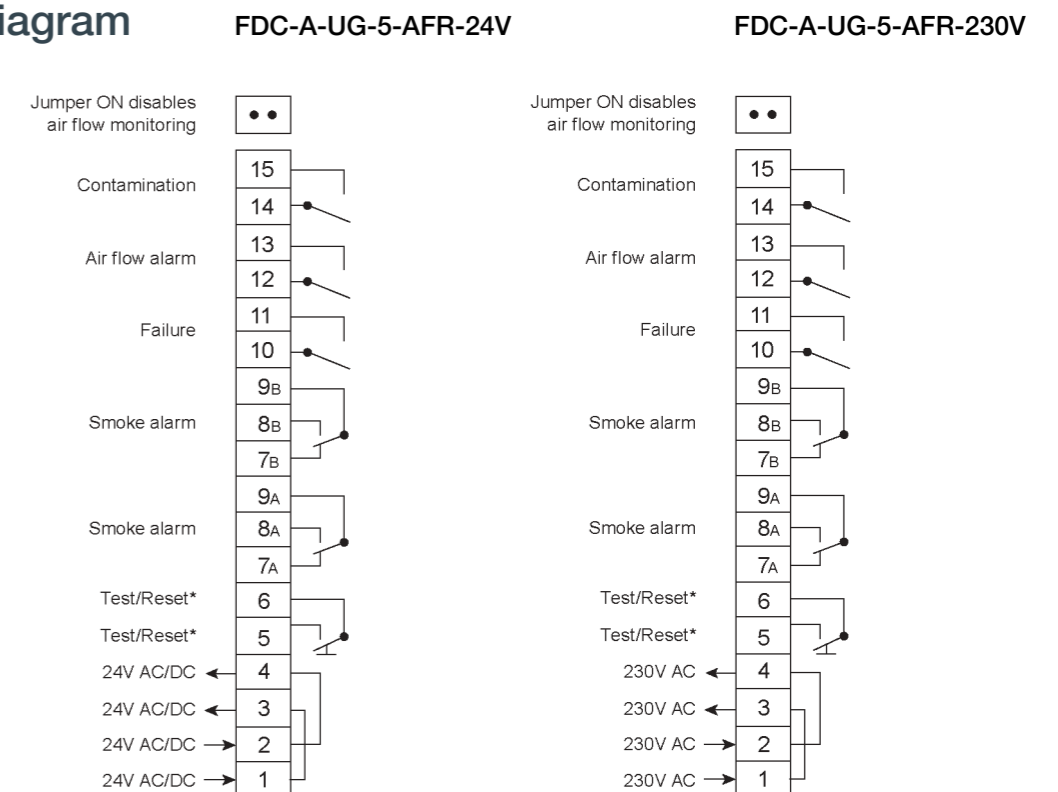

SMOKE SENSOR CASING ROTATION

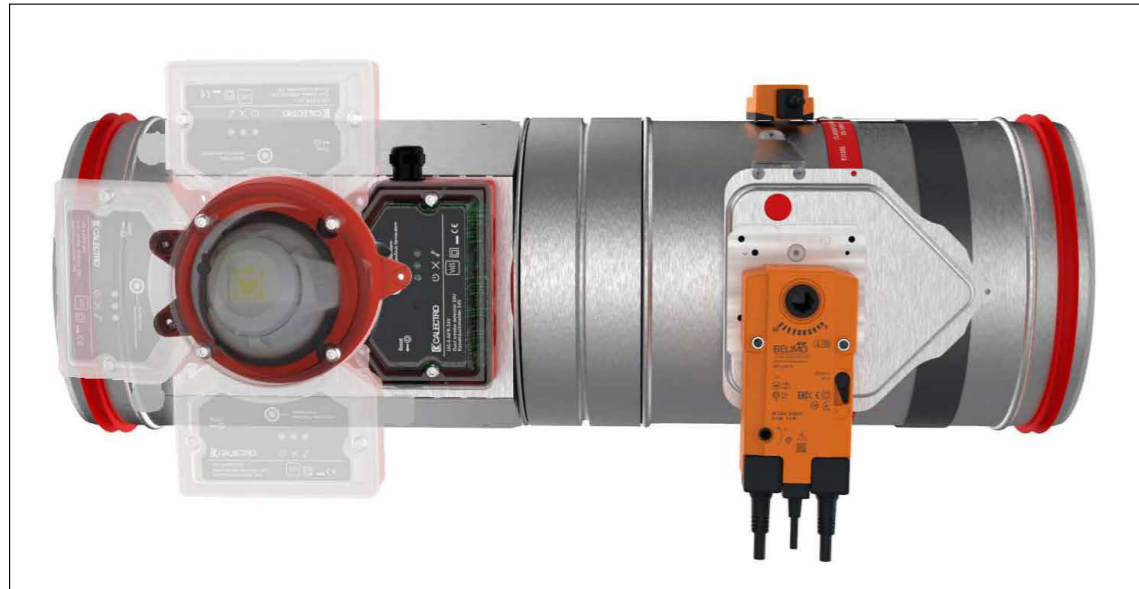

Smoke sensor casing can be rotated (90°-180°-270°) in order to provide better flexibility for wiring.
To rotate smoke sensor casing, follow the below instructions.

1. Follow first step of **smoke sensor rotation**: locate and remove hex screws.
2. Rotate the smoke sensor casing (90° -180° -270°).
3. Fix the screws following the fourth step of **smoke sensor rotation**.

- ▼ [PRODUCT OVERVIEW](#)
- ▼ [DIMENSIONS](#)
- ▼ [INSTALLATIONS](#)
- ▼ [ACTUATORS](#)
- ▼ [ACCESSORIES](#)
- ▼ [REPLACEMENTS](#)
- ▼ [MAINTENANCE AND OPERATION](#)

↻ [REPLACEMENTS](#)

FIRE DAMPER - FDC

SMOKE SENSOR ROTATION

Smoke sensor assembly is supplied with standard airflow direction.
*If you rotate the smoke sensor, the distance of 5 times the hydraulic duct diameter should be left before the sensor!

1. Locate hex screws, unscrew them and remove the cover.
Pay attention to detail A!
2. Remove the casing, locate the screws and remove them.
3. Rotate smoke sensor (0° -180°) according to air flow direction and fix it with screws.
4. Put the casing back and install the cover. **Pay attention to detail A!**

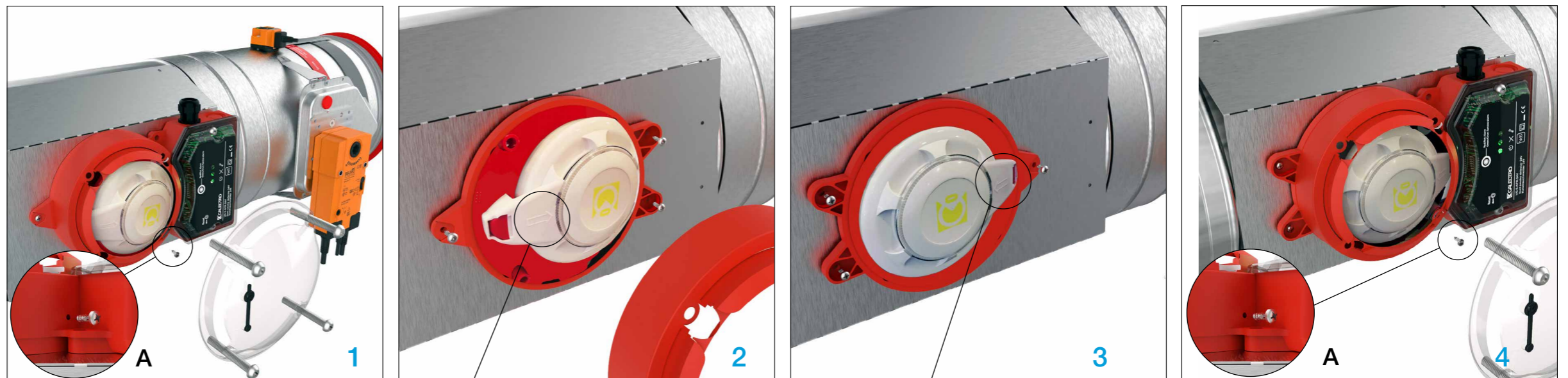

STANDARD AIR FLOW DIRECTION →

← ROTATED AIR FLOW DIRECTION

UPGRADE TO END CONTACTS (R25 → R25-S)

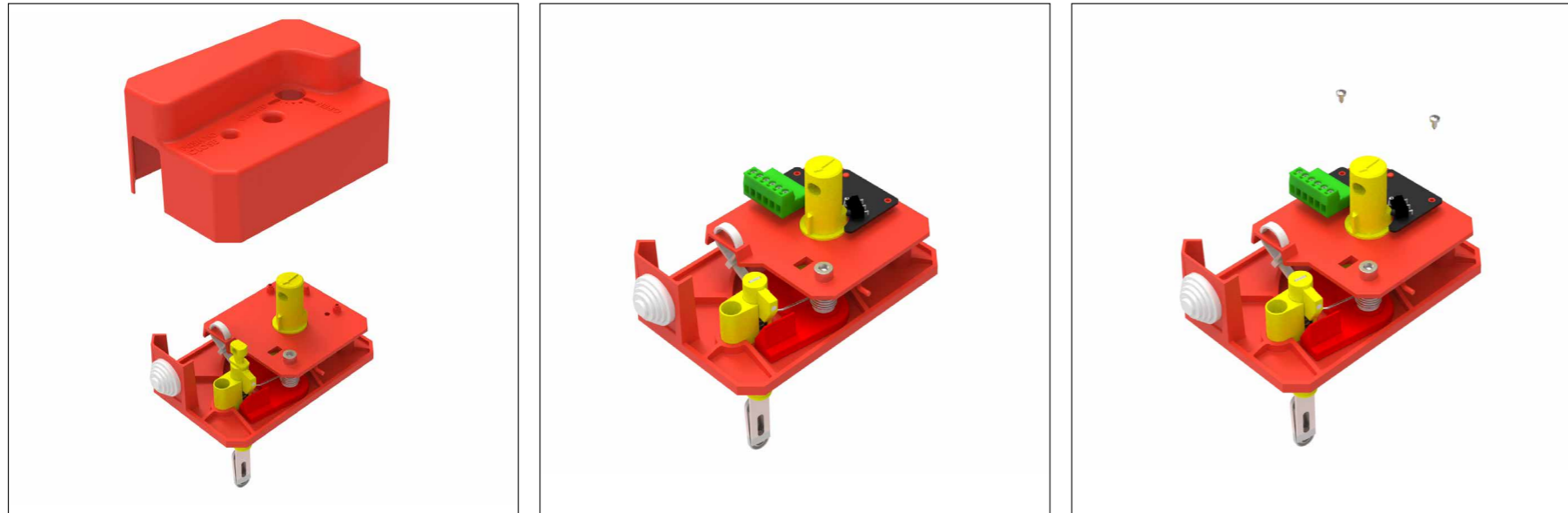

UPGRADE TO END CONTACTS (R40 → R40-S)

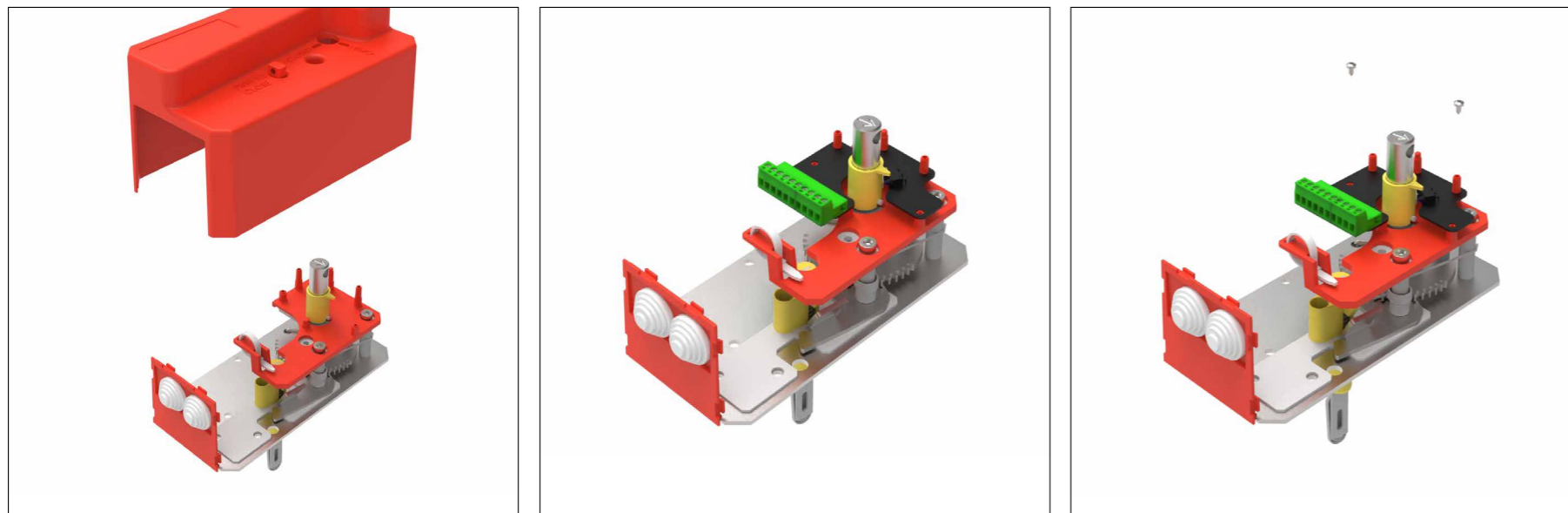

- ▼ [PRODUCT OVERVIEW](#)
- ▼ [DIMENSIONS](#)
- ▼ [INSTALLATIONS](#)
- ▼ [ACTUATORS](#)
- ▼ [ACCESSORIES](#)
- ▼ [REPLACEMENTS](#)
- ▼ [MAINTENANCE AND OPERATION](#)

↻ [REPLACEMENTS](#)

FIRE DAMPER - FDC

1. Locate hex screw, unscrew it and remove the cover.
2. Insert CEE (R25)/CEDC (R40) board in the appropriate place.
3. Screw the board to the plate. Put the cover back in place!

UPGRADE FROM MANUAL (R40-S) TO EMS

Before upgrade R40 to EMS, it is necessary to install kit for end contacts (FD-A-R40S-KIT).

Before upgrade R25/RS25-S to EMS, it is necessary to install R40 mechanism (FD-A-R40) and kit for end contacts (FD-A-R40S-KIT).

To upgrade to EMS you need to use the EMS kit!

Service work may only be performed by authorized persons!



- ▼ [PRODUCT OVERVIEW](#)
- ▼ [DIMENSIONS](#)
- ▼ [INSTALLATIONS](#)
- ▼ [ACTUATORS](#)
- ▼ [ACCESSORIES](#)
- ▼ [REPLACEMENTS](#)
- ▼ [MAINTENANCE AND OPERATION](#)

REPLACEMENTS

FIRE DAMPER - FDC

1. Locate hex screw. Unscrew it and remove the cover.

2. Insert the EMS on the custom plate.

3. Screw the EMS to the plate and connect the 2-pin connector into the appropriate socket on the CEDC board.

4. Put the cover back in place.

Test the operation of the damper blade!



REPLACEMENT OF THERMAL FUSE (R25)



- ▼ [PRODUCT OVERVIEW](#)
- ▼ [DIMENSIONS](#)
- ▼ [INSTALLATIONS](#)
- ▼ [ACTUATORS](#)
- ▼ [ACCESSORIES](#)
- ▼ [REPLACEMENTS](#)
- ▼ [MAINTENANCE AND OPERATION](#)

1. Locate the hex screw on the cover, unscrew it and remove the screw and cover.
2. Locate the hex screw on the thermal fuse and unscrew it.
3. Remove the old thermal fuse. Insert the new thermal fuse and secure it.
4. Put the lid back on.

Test the operation of the damper blade!



REPLACEMENT OF THERMAL FUSE (R40)

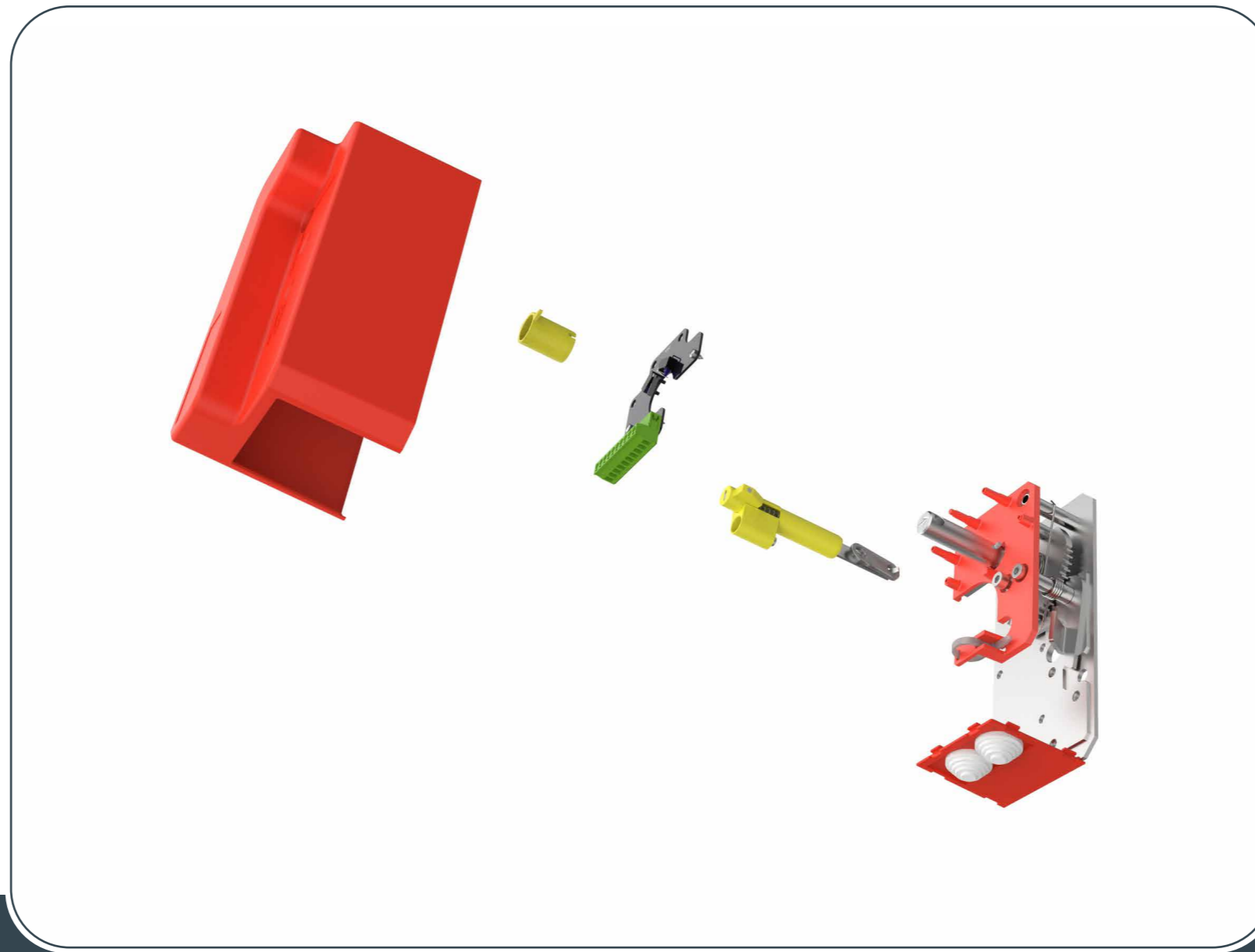

- ▼ [PRODUCT OVERVIEW](#)
- ▼ [DIMENSIONS](#)
- ▼ [INSTALLATIONS](#)
- ▼ [ACTUATORS](#)
- ▼ [ACCESSORIES](#)
- ▼ [REPLACEMENTS](#)
- ▼ [MAINTENANCE AND OPERATION](#)

REPLACEMENTS

FIRE DAMPER - FDC

1. Find the hex screw located on the cover, unscrew and remove the screw and the cover.

2. Remove the position indicator sleeve.

3. Locate the 3 hex screws. Unscrew them. Remove the CEDC board (if applicable).

4. Locate the screw on the thermal fuse. Unscrew it. Remove the old thermal fuse. Insert a new thermal fuse. Put the CEDC board and the cover back in place.

Test the operation of the damper blade!



UPGRADE TO ELECTRIC ACTUATOR

Manual R25 <-> Belimo

d100-d315

The blade must be closed before replacement the mechanism.

Service work may only be performed by authorized persons!

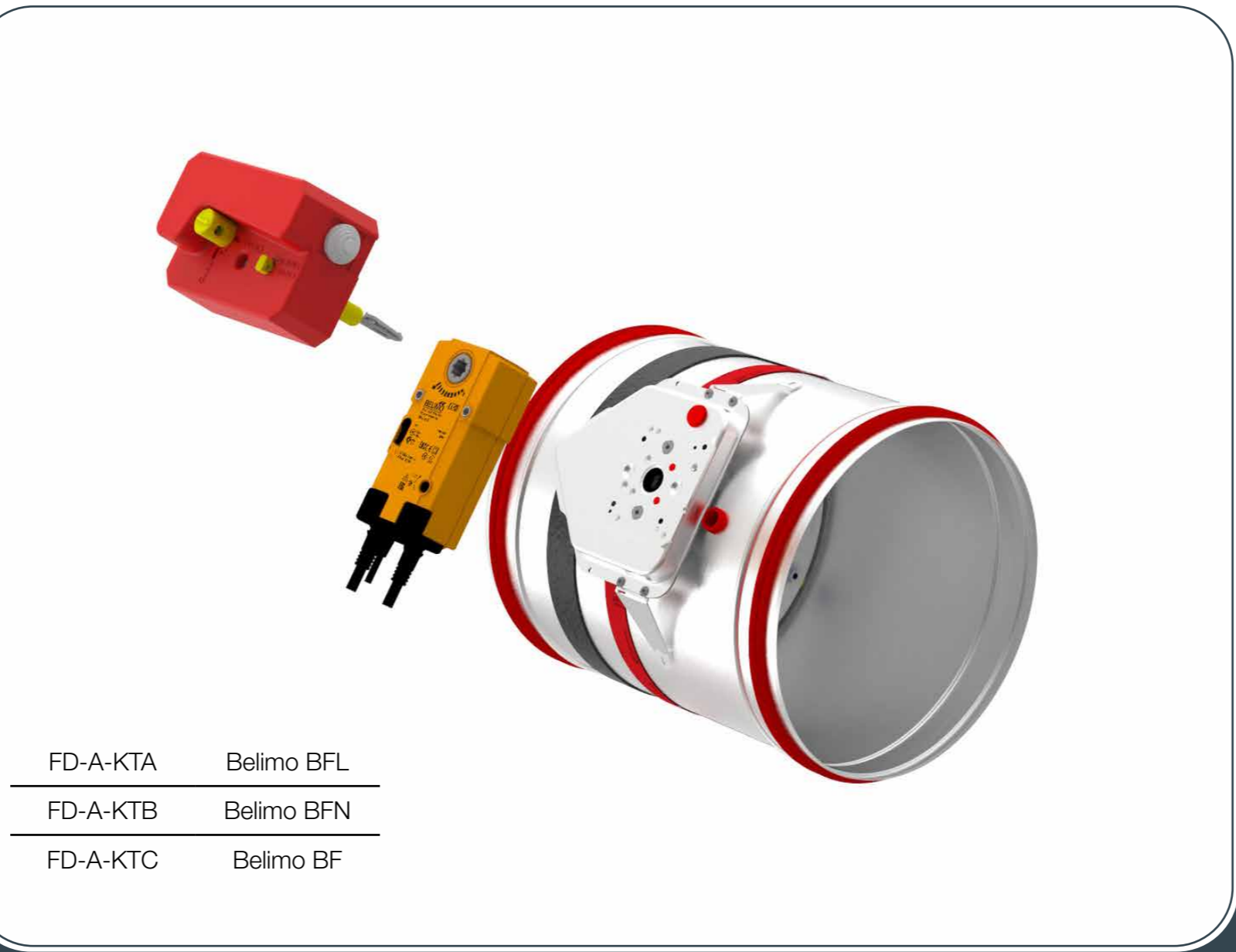

FD-A-KTA	Belimo BFL
FD-A-KTB	Belimo BFN
FD-A-KTC	Belimo BF

- ▼ [PRODUCT OVERVIEW](#)
- ▼ [DIMENSIONS](#)
- ▼ [INSTALLATIONS](#)
- ▼ [ACTUATORS](#)
- ▼ [ACCESSORIES](#)
- ▼ [REPLACEMENTS](#)
- ▼ [MAINTENANCE AND OPERATION](#)

REPLACEMENTS

FIRE DAMPER - FDC

NOTE: Use kit according to table (upgrade to electric actuator)!

* Find the screw and remove the cover!

1. Find the 2 hex screws located on the board of mechanism, unscrew them and remove manual mechanism.

2. Find the 2 hex screws located on the mechanism (E), unscrew them and replace the manual mechanism plate (A) with BE transition plate (B) provided in the kit.

NOTE: Pay attention to the position of indication cut on the BE transition plate.

3. Insert the rubber plug into the opening for the thermal fuse. Install square shaft into the hole, put Belimo actuator on the shaft and fasten the actuator with screws (2 hexagon screws M6x55).

***Check the rotation direction of the actuator!** (Clockwise actuation, R mark on the actuator)

4. Drill hole (ø16 mm) for the fuse of Belimo mechanism and fix it with self-tapping screws.

NOTE: Install the thermal fuse in a place where it will not interfere with the operation of the damper blade!
Test the operation of the damper blade!

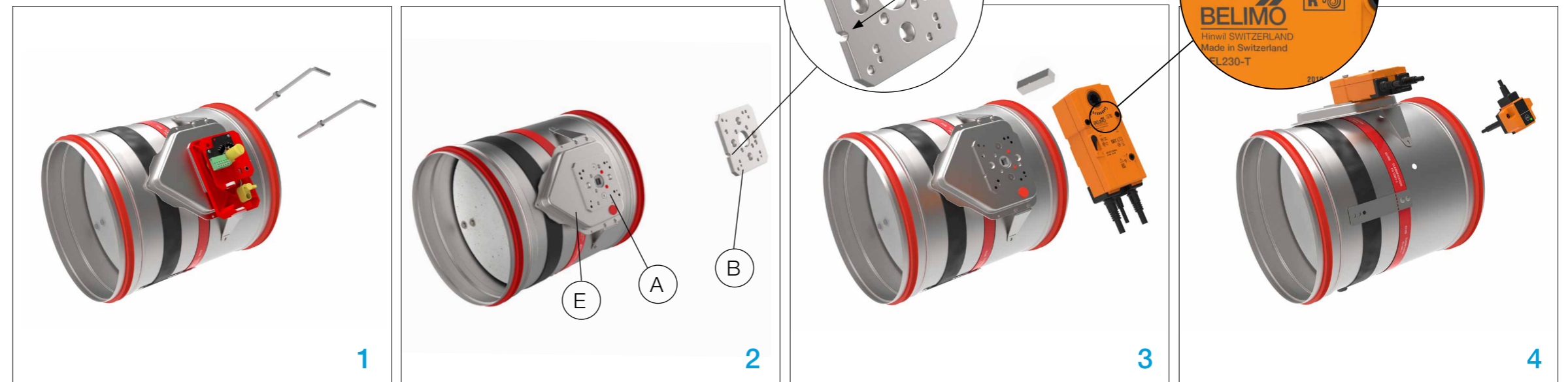

UPGRADE TO ELECTRIC ACTUATOR

R40 <-> Belimo

d355-d800

The blade must be closed before replacement the mechanism.

Service work may only be performed by authorized persons!

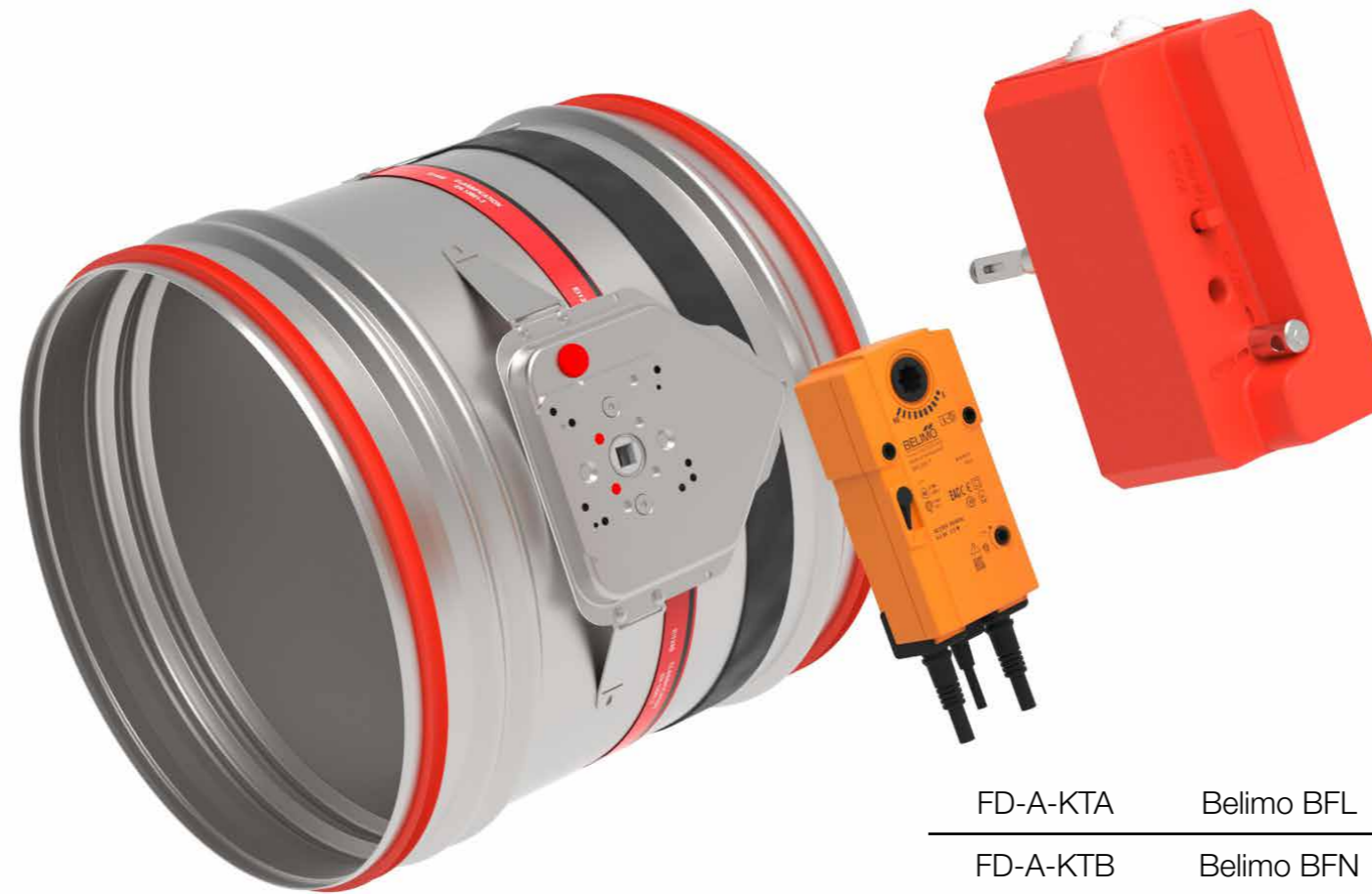

FD-A-KTA	Belimo BFL
FD-A-KTB	Belimo BFN
FD-A-KTC	Belimo BF

- ▼ [PRODUCT OVERVIEW](#)
- ▼ [DIMENSIONS](#)
- ▼ [INSTALLATIONS](#)
- ▼ [ACTUATORS](#)
- ▼ [ACCESSORIES](#)
- ▼ [REPLACEMENTS](#)
- ▼ [MAINTENANCE AND OPERATION](#)

REPLACEMENTS

FIRE DAMPER - FDC

NOTE: Use kit according to table (upgrade to electric actuator)!

* Find the screw and remove the cover!

1. Find the 3 hex screws located on the board of mechanism, unscrew them and remove manual mechanism.

2. Find the 2 hex screws located on the mechanism (E), unscrew them and replace the manual mechanism plate (A) with BE transition plate (B) provided in the kit.

NOTE: Pay attention to the position of indication cut on the BE transition plate.

3. Insert the rubber plug into the opening for the thermal fuse. Install square shaft into the hole put Belimo actuator on the shaft and fasten the actuator with screws (2 hexagon screws M6x55).

***Check the rotation direction of the actuator!** (Clockwise actuation, R mark on the actuator)

4. Drill hole (ø16 mm) for the fuse of Belimo mechanism and fix it with self-tapping screws.

NOTE: Install the thermal fuse in a place where it will not interfere with the operation of the damper blade!
Test the operation of the damper blade!

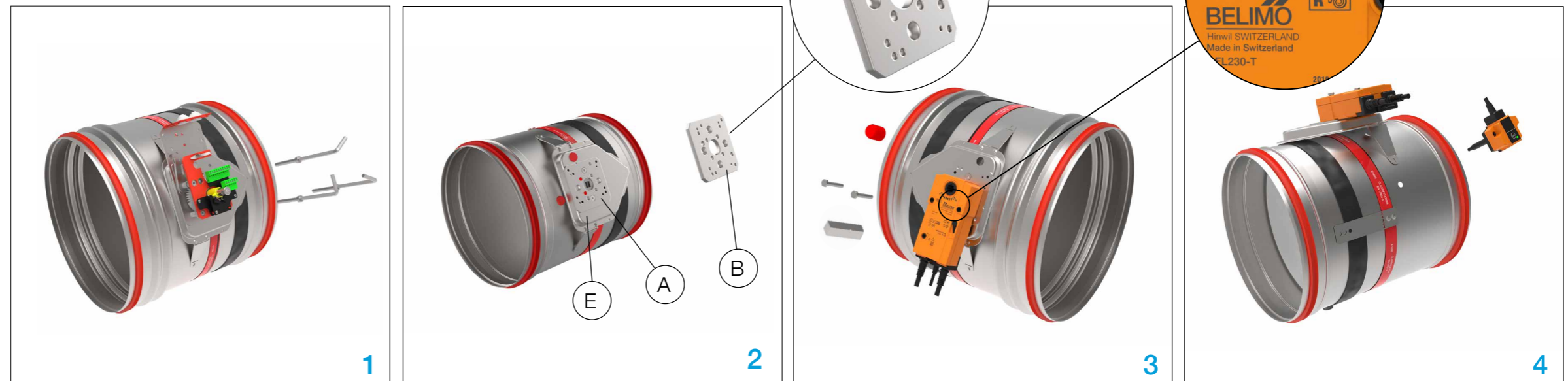

HOW TO ROTATE ELECTRIC ACTUATOR (Belimo)

d100-d800

The blade must be closed before replacement the mechanism.



- ▼ [PRODUCT OVERVIEW](#)
- ▼ [DIMENSIONS](#)
- ▼ [INSTALLATIONS](#)
- ▼ [ACTUATORS](#)
- ▼ [ACCESSORIES](#)
- ▼ [REPLACEMENTS](#)
- ▼ [MAINTENANCE AND OPERATION](#)

REPLACEMENTS

FIRE DAMPER - FDC

1. Locate the 2 hex screws, unscrew and remove them.

2. Remove the Belimo electric actuator.

3. Find the 2 hex screws located on the transition board (B), unscrew them and rotate BE transition plate (A) 90°.

NOTE: The direction of rotation of BE transition plate and the electric actuator must be the same!

4. Fix the transition plate to the transition board and install the Belimo actuator.

Test the operation of the damper blade!



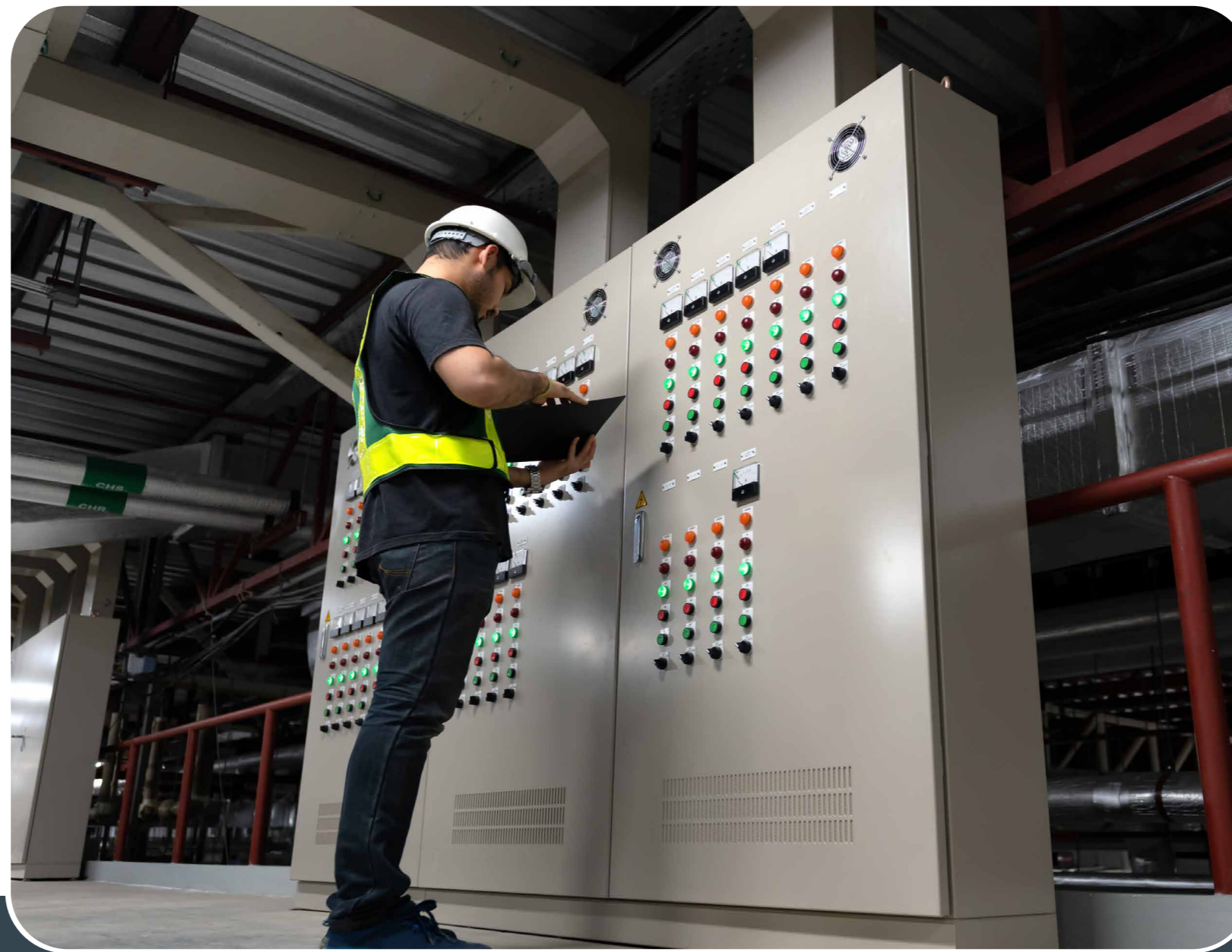

- ▼ [PRODUCT OVERVIEW](#)
- ▼ [DIMENSIONS](#)
- ▼ [INSTALLATIONS](#)
- ▼ [ACTUATORS](#)
- ▼ [ACCESSORIES](#)
- ▼ [REPLACEMENTS](#)
- ▼ [MAINTENANCE AND OPERATION](#)



MAINTENANCE

FIRE DAMPER - FDC

TRANSPORT

After arrival, check the fire damper for transport damage and shortcomings. In case of any damage or shortcomings, immediately contact your supplier.

STORAGE

If the damper is not installed immediately:

- Remove any wrapping.
- Protect fire damper from dust and contamination.
- Do not expose the fire damper to the effects of weather - store fire damper in dry place.
- Do not store the unit below -20 °C or above 50 °C.

Please properly dispose of packaging material.

MAINTENANCE AND OPERATION

Fire dampers are designed with fully enclosed drive mechanism outside of the duct and as such do not require cleaning and regular maintenance.

However, activation mechanism should be inspected for proper operation on regular basis.

- Provide regular testing/inspection of the fire dampers. Inspection/test intervals should be carried out every six months or less according to the local legislature
- After each intervention, provide a systematic cleaning of dust and especially the solenoid and its movable plate
- Check the if the electrical terminals are tightened
- Cleaning instruction: clean with a sponge, with water or a mild detergent
- Disinfection instruction: spray disinfectant (disinfectant may contain alcohol which is flammable, take precaution

to avoid ignition)

It is not permitted to alter the dampers in any way nor perform any changes to their structure (except for the service procedures described in this manual) without the manufacturer's consent. Provide at least one annual check of the damper. The functional test must be carried out in compliance with the basic maintenance principles of the European norms EN 13306, EN 15423 and EN15650

COMMISSIONING

- Carefully unpack FDC fire damper - be careful of sharp edges and do not use excessive force for unpacking
- Inspect the fire damper - check the fire damper for damage
- Installation of the fire damper - according to the installation instructions ([page 14.](#)).
- Before commissioning: check the fire damper functions.

FUNCTIONS

- Release mechanism:
Damper blade can be closed and opened manually
- 2) EMS:
Signal testing - the damper blade must close
- 3) Electric actuator:
Signal testing - the damper blade must close/open
- 4) Thermal fuse:
By a button - the damper blade must be closed by pressing the button

FIRE DAMPER TESTING

MANUAL ACTUATORS/ SOLENOID ACTUATOR

1. Close the damper blade by pushing the thermic actuator through the hole on the casing.

2. Open the damper blade by inserting the metal rod (i.e. screwdriver, hex wrench) max. 7 mm in diameter, into the yellow/ silver part and rotate the arrow to the open position.



- ▼ [PRODUCT OVERVIEW](#)
- ▼ [DIMENSIONS](#)
- ▼ [INSTALLATIONS](#)
- ▼ [ACTUATORS](#)
- ▼ [ACCESSORIES](#)
- ▼ [REPLACEMENTS](#)
- ▼ [MAINTENANCE AND OPERATION](#)



FIRE DAMPER - FDC

ELECTRIC ACTUATOR





1. Test the operation of the damper blade by pushing the test button.

2. Opening the damper blade:
Insert the handle provided with the Belimo actuator into the hole. Rotate it as shown on the actuator.





SMOKE CONTROL DAMPERS

 Systems House, Unit 33, Southern Cross, Business Park, Bray, Co. Wicklow, A98 HT99
 +353 1 2761600
 info@safegard.ie
 www.safegard.ie
