

Product manual

---

# ThermShield FDC-DD EIS Classified Fire Damper

---

Fire protection

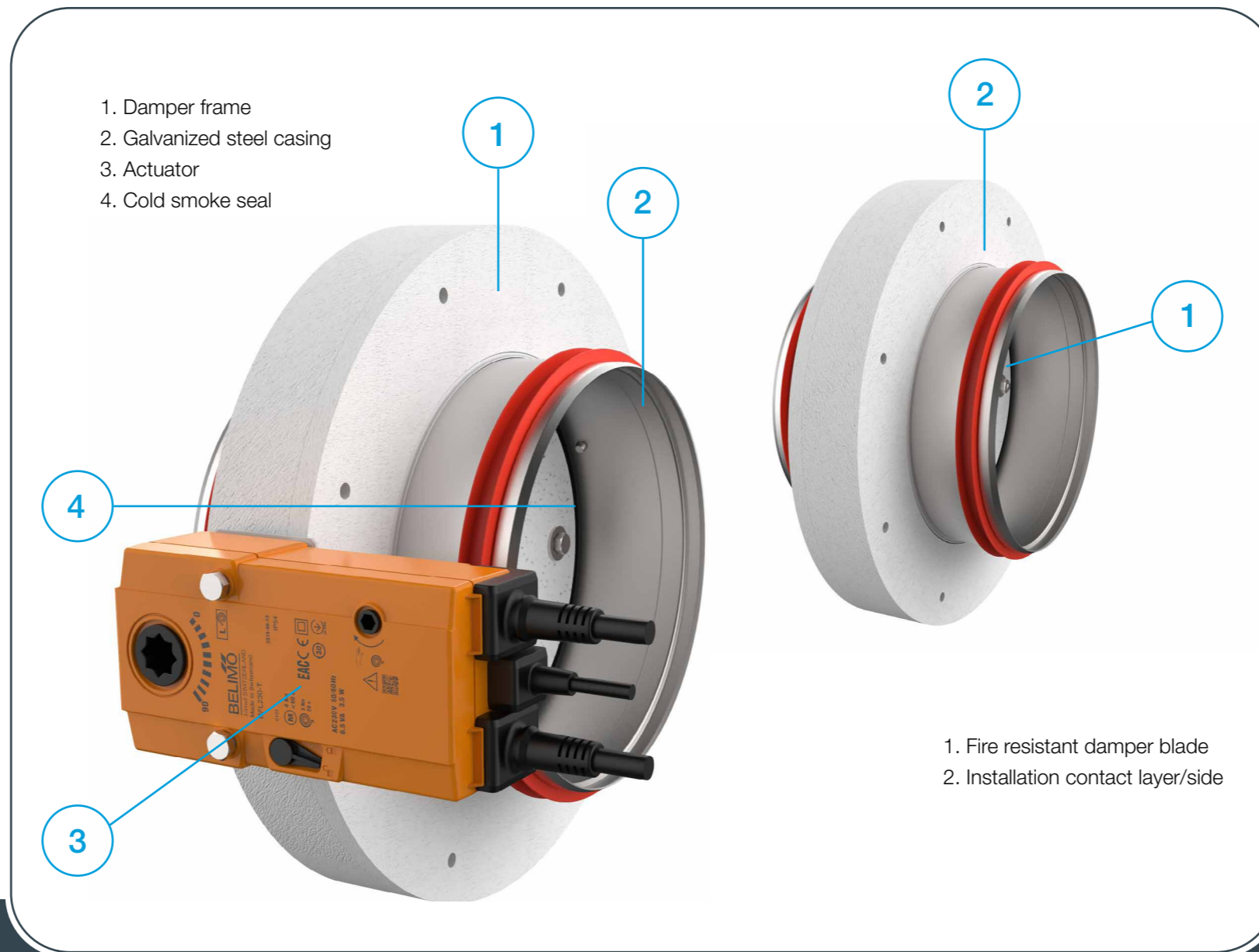

- ▼ [PRODUCT OVERVIEW](#)
- ▼ [DIMENSIONS](#)
- ▼ [INSTALLATIONS](#)
- ▼ [ACTUATORS](#)
- ▼ [ACCESSORIES](#)
- ▼ [MAINTENANCE AND OPERATION](#)

\* The images shown are for illustration purposes only and may not be an exact representation of the product.

## PRODUCT OVERVIEW

Fire dampers FDC-DD are used for prevention of fire spread through the ventilation ducts and between the fire sections. Fire damper FDC-DD consists of galvanized sheet metal casing, calcium silicate damper blade, high temperature resistant installation frame made from calcium silicate and electric actuator.

Fire damper casing is made out of galvanized steel sheet. Variants produced from stainless steel and powder coated steel are also available. Calcium silicate blade is equipped with brass bearings and seals. Brass bearings are pressed into the casing. Calcium silicate blade is equipped with the seal made out of EPDM rubber.

Fire dampers FDC-DD are produced up to size d315 and have 25 mm thick damper blade.

Fire dampers are equipped with Belimo electric actuators (24 V or 230 V versions). Actuator's spring closes the damper blade when its thermal fuse senses the ambient temperature has reached 72°C. Closing and reopening of damper blade can also be done remotely via control signal.

Declared blade airtightness - class 3 and casing airtightness - class C are tested according to EN 1751.



- ▼ [PRODUCT OVERVIEW](#)
- ▼ [DIMENSIONS](#)
- ▼ [INSTALLATIONS](#)
- ▼ [ACTUATORS](#)
- ▼ [ACCESSORIES](#)
- ▼ [MAINTENANCE AND OPERATION](#)

## FIRE RESISTANCE CLASSIFICATION

FDC-DD fire resistance is tested according to EN 1366-2 "Fire resistance tests for service installations- Part 2: Fire dampers". Classification of the fire dampers is defined according to EN 13501-3 Fire classification of construction products and building elements.

Installation in both, vertical and horizontal axis of rotation of the dampers blade is acceptable (with the axis angle 0 - 360°). Fire resistance of fire damper depends on classification of walls. It is allowed to install products to walls only according to products Declaration of Performance. Walls with greater fire resistance can also be used. Fire damper should be installed according to the installation manual which can be found within this document.

- E** - Integrity
- I** - Insulation
- 60** - Classification time in minutes
- S** - Smoke leakage
- ve** - Damper installed in vertical compartment
- ho** - Damper installed in horizontal compartment
- i↔o** - Fire performance criteria are met on both sides



**1** CLASS C EN1751

**SAFEGARDSYSTEMS**  
A Swegon Group company

**2** Serial Number: 20152380030001

**3** Production Date: 09.05.2022.

**4** Type: FDC-DD-d100-M230-S

**5** Dimension: d100



**15**

Act. Mechanism: M230 **6**

Nominal Voltage: AC 230 **7**

Signalisation: Yes **8**

IP Protection: IP54 **9**

Free Space (dm2): 0,5 **10**

Termal Fuse: 72 **11**

DOP EN15650:2010 717/2022 **12** **13**

EI60 (Ve i < - > o)S 300Pa **14**

For fire classification of product  
consult declaration of performance.

Install according to the instructions!

**16** CE 1812 17  
2483-CPR-10117

USER MANUALS



- [▼ PRODUCT OVERVIEW](#)
- [▼ DIMENSIONS](#)
- [▼ INSTALLATIONS](#)
- [▼ ACTUATORS](#)
- [▼ ACCESSORIES](#)
- [▼ MAINTENANCE AND OPERATION](#)

FIRE DAMPER - FDC-DD

## TECHNICAL DATA

Fire damper casing is manufactured from galvanized steel sheet, but on demand can be produced out of:

- Galvanized steel and powder coated

### Product label

- 1 - Casing air leakage classification
- 2 - Serial number
- 3 - Production date
- 4 - Type
- 5 - Dimension of the fire damper
- 6 - Mechanism type
- 7 - Nominal voltage
- 8 - Signalisation (end contacts)
- 9 - IP protection
- 10 - Free space
- 11 - Thermal fuse temperature
- 12 - Number of the European standard and year of its publication
- 13 - Declaration of performance
- 14 - Classification according to EN 13501-3
- 15 - Barcode
- 16 - CE mark

### Product specifications

Nominal sizes FDC-DD	100 - 315 [mm]
Casing length	170 mm
Temperature range	-20 °C ... 50 °C
Release temperature	72 °C (standard)
Volume flow rate range	up to 21700 m <sup>3</sup> /h
Differential pressure range	up to 600 Pa
Casing air leakage	Class C, EN 1751
Closed blade air leakage	Class 3, EN 1751
Upstream velocity	< 12 m/s
EC conformity	EN 13501-3, EN 1366-2, EN 15650, EN 1751, CPR no.305/2011
Declaration of performance	DoP 717/2022

### Pressure drop tables

Pressure drop values are described with the “Zeta” values for each size. The exact pressure drop in [Pa] is calculated using the following formula:

$$\Delta p \text{ [Pa]} = \zeta * v^2 * 0,6$$

where  $\zeta$  is Zeta value from the tables below, v is airflow velocity in [m/s]

FDC-DD	d100	d125	d160	d200	d250	d315
$\zeta$	1,759	0,852	0,545	0,445	0,340	0,293

# FDC - DD

## Dimensional range

Model	Diameter Ød [mm]	Cross section [dm <sup>2</sup> ]	Net area [dm <sup>2</sup> ]
FDC-DD D100	98	0,74	0,50
FDC-DD D125	123	1,17	0,87
FDC-DD D160	158	1,93	1,55
FDC-DD D200	198	3,05	2,56
FDC-DD D250	248	4,79	4,18
FDC-DD D315	313	7,64	6,87



- ▼ [PRODUCT OVERVIEW](#)
- ▼ [DIMENSIONS](#)
- ▼ [INSTALLATIONS](#)
- ▼ [ACTUATORS](#)
- ▼ [ACCESSORIES](#)
- ▼ [MAINTENANCE AND OPERATION](#)

DIMENSIONS

FIRE DAMPER - FDC-DD

## Weights (with Belimo actuator 1,1kg)

Model	Weight [kg]
FDC-DD D100	3,022
FDC-DD D125	3,389
FDC-DD D160	3,94
FDC-DD D200	4,619
FDC-DD D250	5,547
FDC-DD D315	6,879

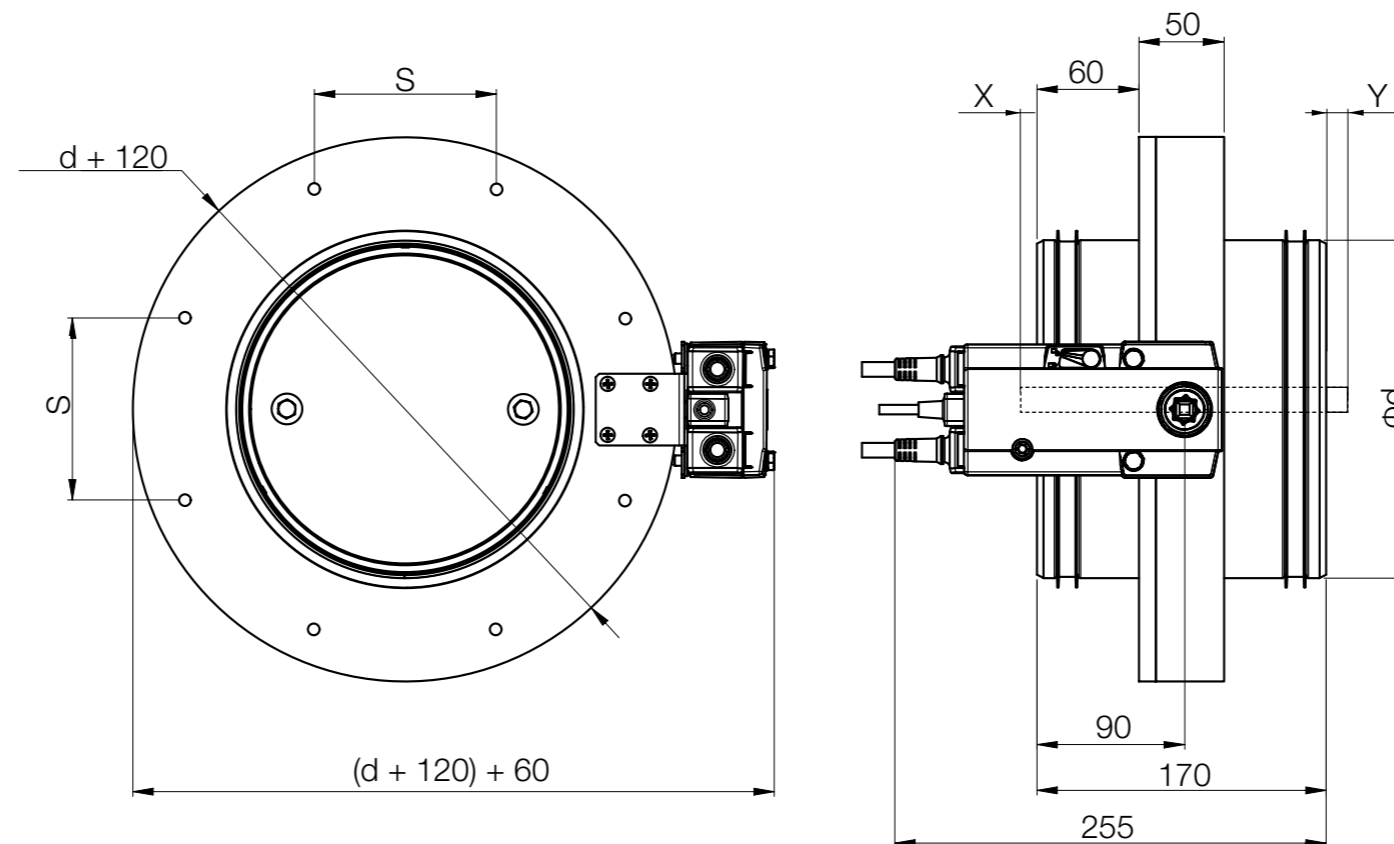

## Length of damper blade outside of casing

Model	S	X side	Y side
FDC-DD D100	68	/	/
FDC-DD D125	78	/	/
FDC-DD D160	92	/	/
FDC-DD D200	107	12,1 mm	15,9 mm
FDC-DD D250	126	37,1 mm	40,9 mm
FDC-DD D315	140	69,6 mm	73,4 mm

## MODELS

### Casings

#### FDC-DD

Cylindrical fire damper with 25 mm damper blade and fire classification up to EI 60S. Sizes range from d100 till d315.



- ▼ [PRODUCT OVERVIEW](#)
- ▼ [DIMENSIONS](#)
- ▼ [INSTALLATIONS](#)
- ▼ [ACTUATORS](#)
- ▼ [ACCESSORIES](#)
- ▼ [MAINTENANCE AND OPERATION](#)



PRODUCT OVERVIEW

FIRE DAMPER - FDC-DD

### Actuators

#### M230-S

Belimo 230 V electro motor operating mechanism, comes with integrated end switches. In case of fire, the fire damper closes automatically.

Damper closing can be initiated either by thermoelectric release device or remotely by triggering the electro motor. Upon closure, damper blade is locked in closed position and can be opened by sending a signal to electro motor. Standard thermoelectric release point is 72 °C.

#### M24-S

Belimo 24 V electro motor operating mechanism, comes with integrated end switches. In case of fire, the fire damper closes automatically.

Damper closing can be initiated either by thermoelectric release device or remotely by triggering the electro motor. Upon closure, damper blade is locked in closed position and can be opened by sending a signal to electro motor. Standard thermoelectric release point is 72 °C.

### Ordering key

(1) Damper type (2) Dimension (3) Actuator type

**FDC-DD - d250 - M230-S**

(1) **FDC-DD**

(2) Damper diameter  
**d100 till d315**

(3) Actuator type:  
**M230-S** - electric actuator AC/DC 230 V  
**M24-S** - electric actuator AC/DC 24 V  
**M24-S-ST** - electric actuator AC/DC 24 V  
with connection plug

## INSTALLATION

The FDC-DD fire damper is always tested in standardized support frames (both in a rigid wall and in a flexible wall) in accordance with EN 1366-2: 2015. The results obtained are valid for all similar support frames which have a thickness and/ or density and/ or fire resistance similar or greater than the one on the test.

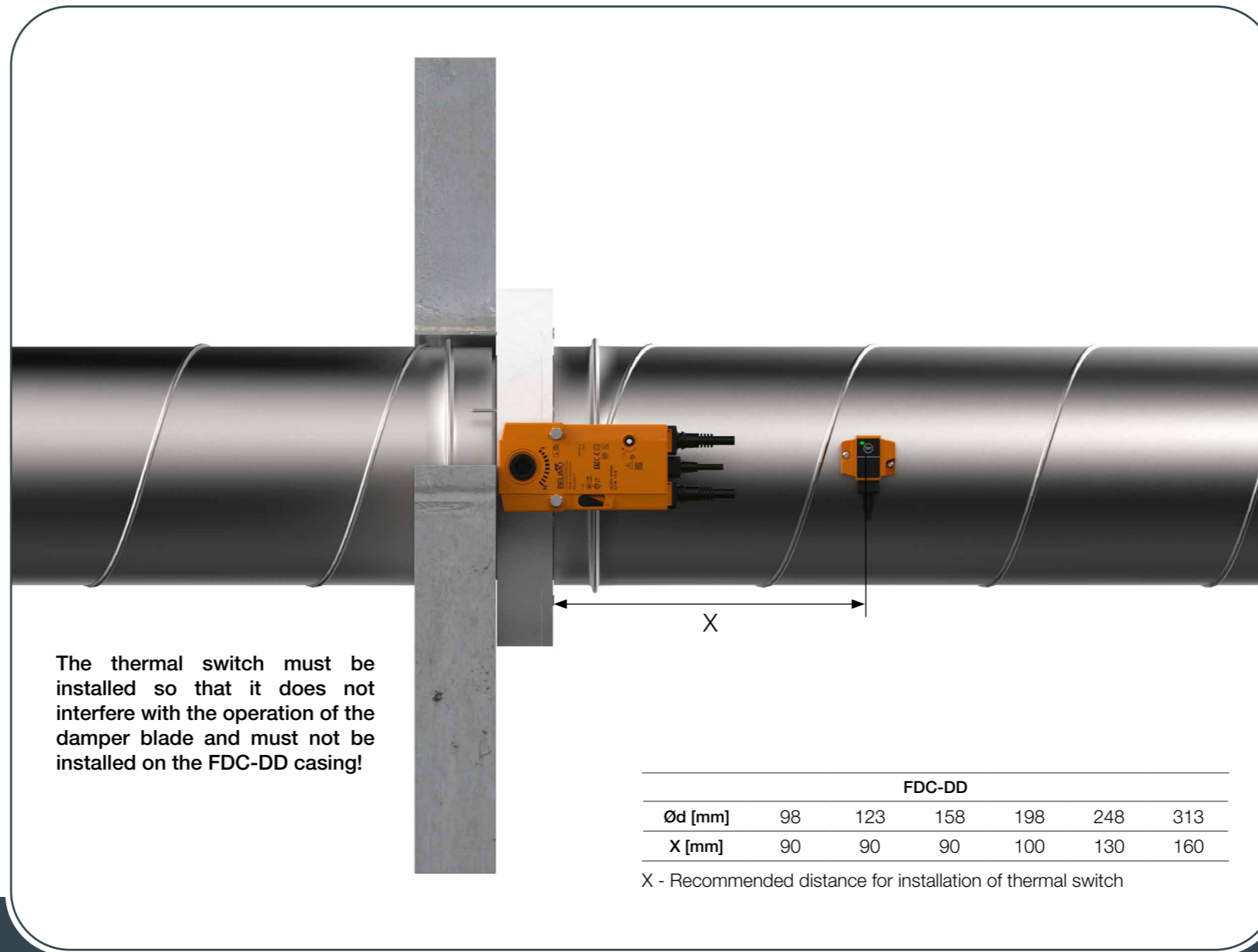

- ▼ [PRODUCT OVERVIEW](#)
- ▼ [DIMENSIONS](#)
- ▼ [INSTALLATIONS](#)
- ▼ [ACTUATORS](#)
- ▼ [ACCESSORIES](#)
- ▼ [MAINTENANCE AND OPERATION](#)



### INSTALLATION

### FIRE DAMPER - FDC-DD

The duct connected to the fire damper must be supported or hung in such a way that the damper does not carry its weight. The damper must not support any part of the surrounding construction or wall which could cause damage and consequent damper failure. It is recommended to connect the damper with a flexible connection on either end of the damper. The damper driving mechanism can be placed on either side of the wall, however it needs to be placed in such way that it ensures an easy access during inspection.

- Mounting is possible with the blade axis in horizontal or in vertical position
- The installation must comply with the tests that were performed during certification
- Avoid any obstruction of the moving blade by the connected ducts
- The class of air-tightness is maintained in case the installation of the damper is made in accordance with the technical manual
- Operating temperature: 50 °C max
- For indoor use only

The gap in the installation opening between the fire damper and the wall/ceiling can be increased by up to 50%, or decreased to the smallest dimension where there is sufficient space for installation of the seal!

Recommended opening dimensions:





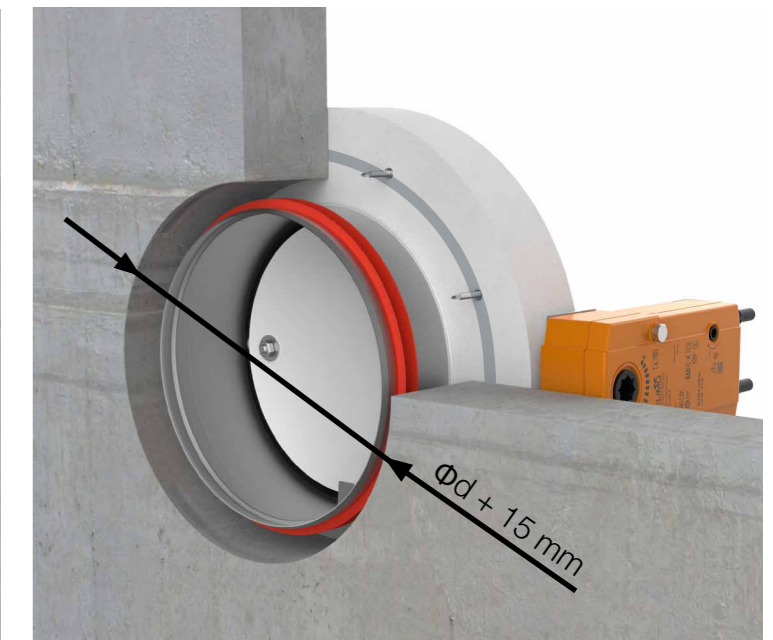
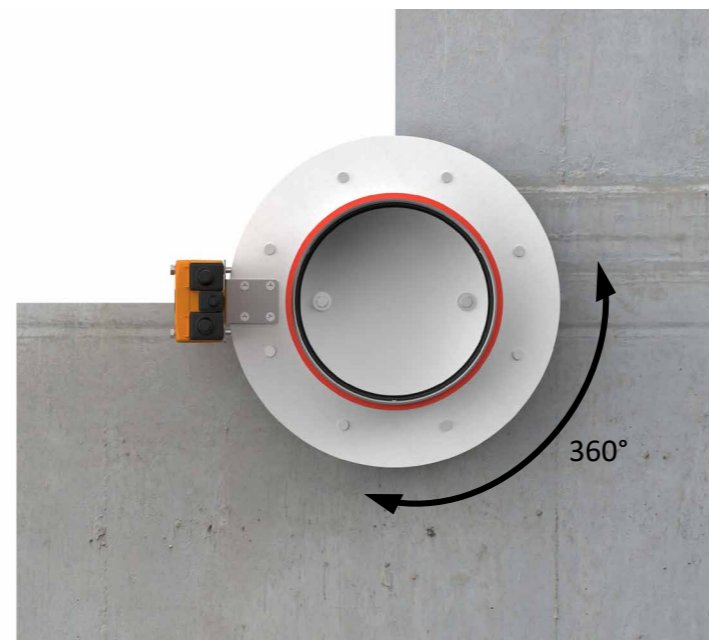







Damper size - Ød [mm]	Opening size - Ød+2A (Max)
Ød	Ød + 15 mm





Installation in both, vertical and horizontal axis of rotation of the dampers blade is acceptable (rigid walls with the axis angle 0 - 360°, flexible walls 0° - 90° - 180° - 270° - 360°).



 **INSTALLATION**

Check for more information about certificate installations in the declaration of performance:

Range	Supporting construction	Wall thickness	Supporting construction details	Type of installation	Classification	Tested underpressure	Details	Construction type	Sealing type	
FDC-DD	Rigid wall	≥ 100 mm	Aerated concrete (≥ 550kg/m <sup>3</sup> ) Reinforced concrete (≥ 2200kg/m <sup>3</sup> )	/	EI 60 (ve i↔o)S	300Pa				
		≥ 70 mm	Gypsum blocks (≥ 995kg/m <sup>3</sup> )	/	EI 60 (ve i↔o)S	300Pa				
	Flexible wall	≥ 100 mm	A: Plasterboard type F (EN520), mineral wool up to 60 kg/m <sup>3</sup>		/	EI 60 (ve i↔o)S	300Pa			
			B: Plasterboard type A (EN520), mineral wool up to 60 kg/m <sup>3</sup>							
		≥ 100 mm	A: Plasterboard type F (EN520), mineral wool up to 60 kg/m <sup>3</sup> B: Plasterboard type A (EN520), mineral wool up to 60 kg/m <sup>3</sup>		Installation with profile inserts	EI 60 (ve i↔o)S EI 60 (ve i↔o)S	300Pa			

-  Aerated concrete (≥ 550 kg/m<sup>3</sup>) or reinforced concrete (≥ 2200 kg/m<sup>3</sup>) wall, more than 100 mm thick
-  Gypsum blocks (≥ 995 kg/m<sup>3</sup>) wall, more than 100 mm thick
-  Plasterboard wall, type F (EN520), Plasterboard wall, type A (EN520), more than 100 mm thick
-  Plasterboard wall, type F (EN520), Plasterboard wall, type A (EN520), more than 100 mm thick

**FIRE DAMPER - FDC-DD**

 FDC-DD installation

## Rigid wall installation

The wall is composed of concrete blocks (minimum density of 550 kg/m<sup>3</sup>) or reinforced concrete (minimum density of 2200 kg/m<sup>3</sup>) and with a minimum thickness of 100 mm.



### INSTALLATION



- ▼ [PRODUCT OVERVIEW](#)
- ▼ [DIMENSIONS](#)
- ▼ [INSTALLATIONS](#)
- ▼ [ACTUATORS](#)
- ▼ [ACCESSORIES](#)
- ▼ [MAINTENANCE AND OPERATION](#)

Possible damper orientations



### FIRE DAMPER - FDC-DD

1. Create a wall opening.

2. Before installing the damper on the wall, it is necessary to apply a thin strip of silicone to the contact layer of calcium silicate.  
\*Use silicone resistant to elevated temperatures.

3. Insert fire damper into the wall and fasten with screws (8 pcs, 6x100 mm).

4. OPTIONAL Seal the gap on the opposite side of the wall with silicone resistant to elevated temperatures. NOTE! Fire dampers are tested and classified without the sealing on the opposite side of the wall. This sealing is for visual purposes only, and does not affect the performance of the fire damper.

**Damper blade must be closed during installation!**

**Test the operation of the damper blade!**

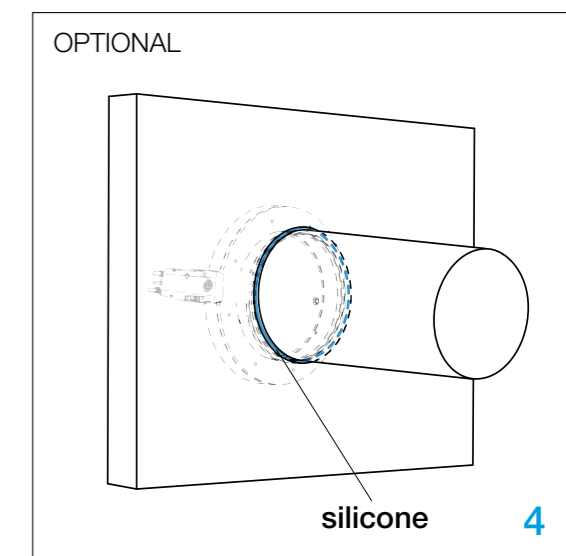
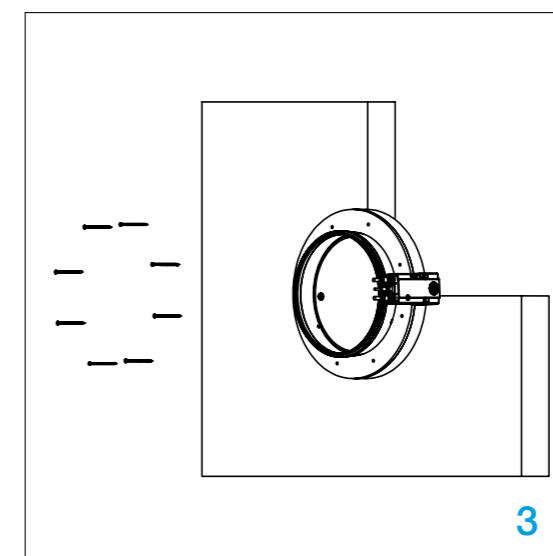
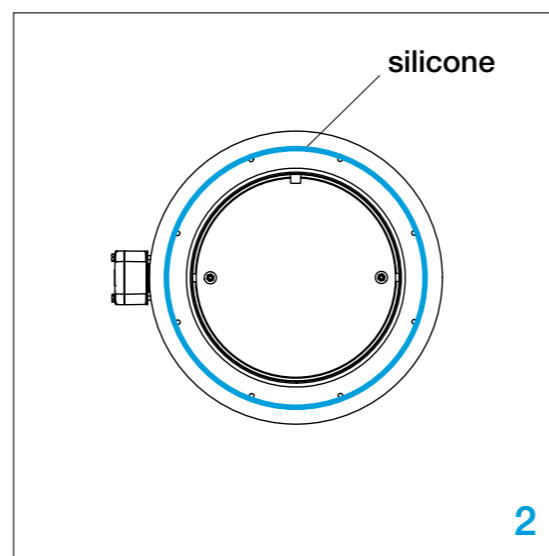
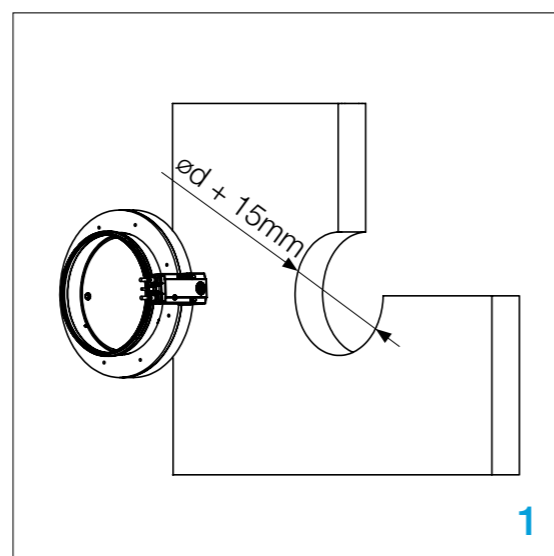

## Gypsum blocks wall installation

The wall is composed of gypsum blocks (minimum density of 995 kg/m<sup>3</sup>), and with minimum thickness of 70 mm.



### INSTALLATION



- ▼ [PRODUCT OVERVIEW](#)
- ▼ [DIMENSIONS](#)
- ▼ [INSTALLATIONS](#)
- ▼ [ACTUATORS](#)
- ▼ [ACCESSORIES](#)
- ▼ [MAINTENANCE AND OPERATION](#)

Possible damper orientations



FIRE DAMPER - FDC-DD

1. Create a wall opening.

2. Before installing the damper on the wall, it is necessary to apply a thin strip of silicone to the contact layer of calcium silicate.  
\*Use silicone resistant to elevated temperatures.

3. Insert fire damper into the wall and fasten with screws (8 pcs, 6x100 mm).

4. OPTIONAL Seal the gap on the opposite side of the wall with silicone resistant to elevated temperatures. NOTE! Fire dampers are tested and classified without the sealing on the opposite side of the wall. This sealing is for visual purposes only, and does not affect the performance of the fire damper.

**Damper blade must be closed during installation!**

**Test the operation of the damper blade!**

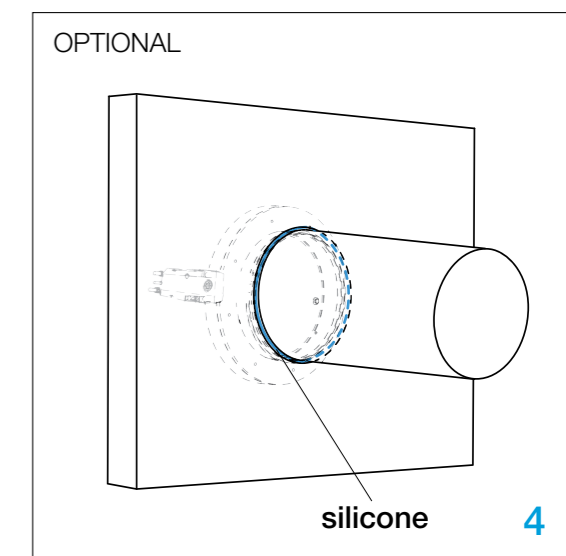
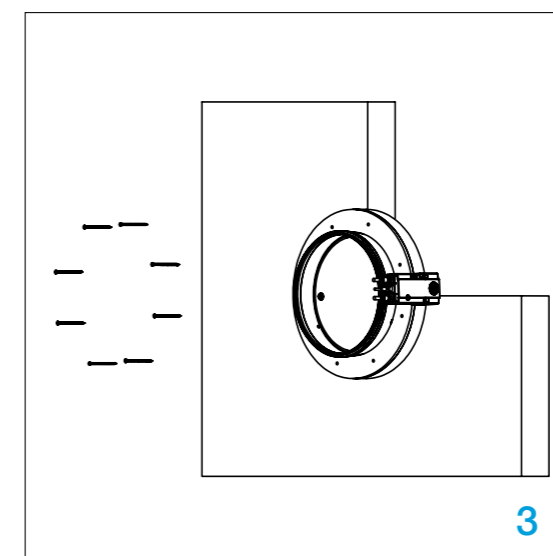
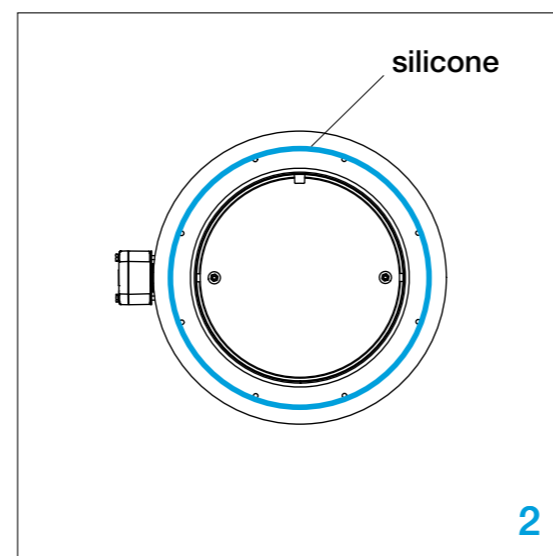
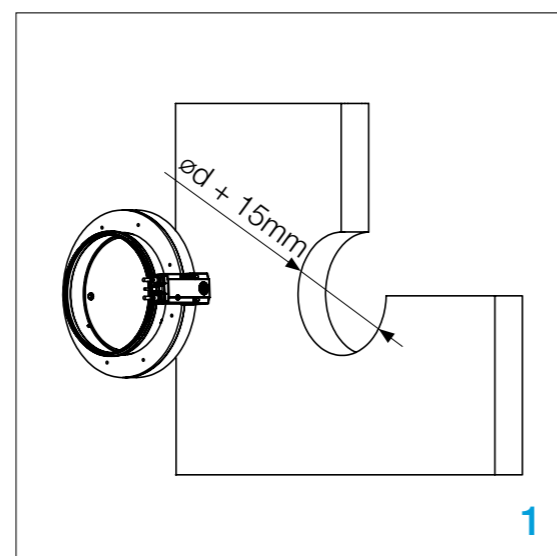

## Flexible wall installation

The wall is composed of 2x2 plasterboard boards, 12,5 mm thick, installed on a steel frame construction. To fulfill the classification it is **NOT** mandatory to use the mineral wool inside the wall (mineral wool with density up to 60 kg/m<sup>3</sup> can be used). The minimum thickness of the wall is 100 mm.

### With subframe for flexible wall

The wall is made out of type F or type A (EN520) plasterboard - **EI 60 (ve i↔o)S**

### With profile inserts

The wall is made out of type F (EN520) - **EI 60 (ve i↔o)S** or type A (EN520) - **EI 60 (ve i↔o)S** plasterboard.



[Video instructions](#)



INSTALLATION



- ▼ [PRODUCT OVERVIEW](#)
- ▼ [DIMENSIONS](#)
- ▼ [INSTALLATIONS](#)
- ▼ [ACTUATORS](#)
- ▼ [ACCESSORIES](#)
- ▼ [MAINTENANCE AND OPERATION](#)

Possible damper orientations



FIRE DAMPER - FDC-DD

### Create subframe for installation in flexible wall!

[\(page 13.\)](#)

1. Create a wall opening.
2. Before installing the damper on the wall, it is necessary to apply a thin strip of silicone to the contact layer of calcium silicate.  
\*Use silicone resistant to elevated temperatures.
3. Insert fire damper into the wall and fasten with screws (8 pcs, 6x100 mm).
4. OPTIONAL Seal the gap on the opposite side of the wall with silicone resistant to elevated temperatures. NOTE! Fire dampers are tested and classified without the sealing on the opposite side of the wall. This sealing is for visual purposes only, and does not affect the performance of the fire damper.

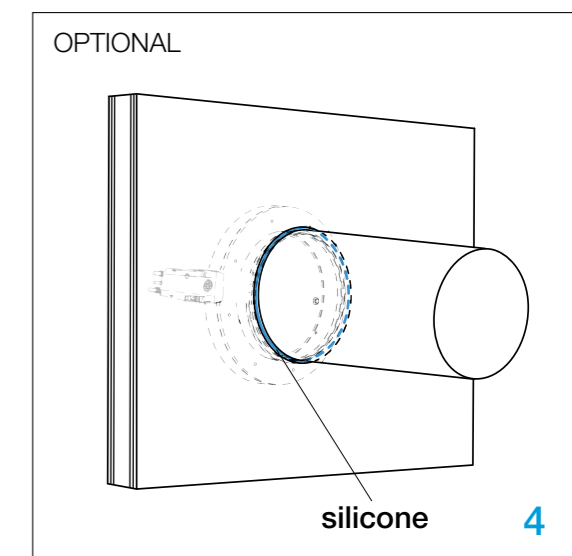
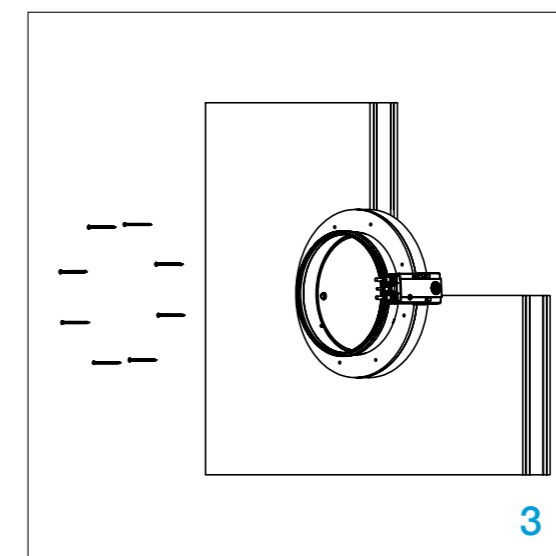
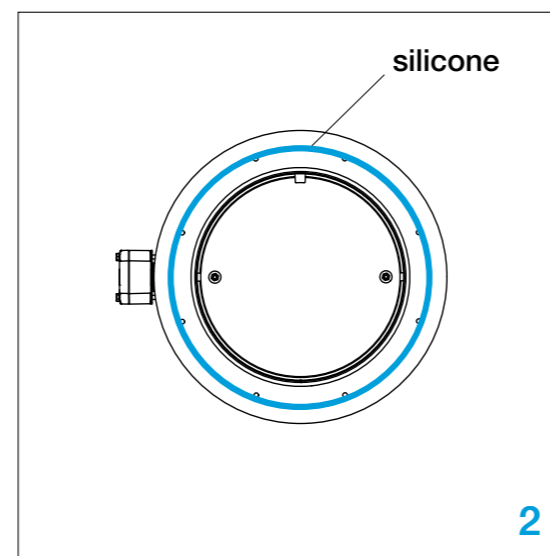
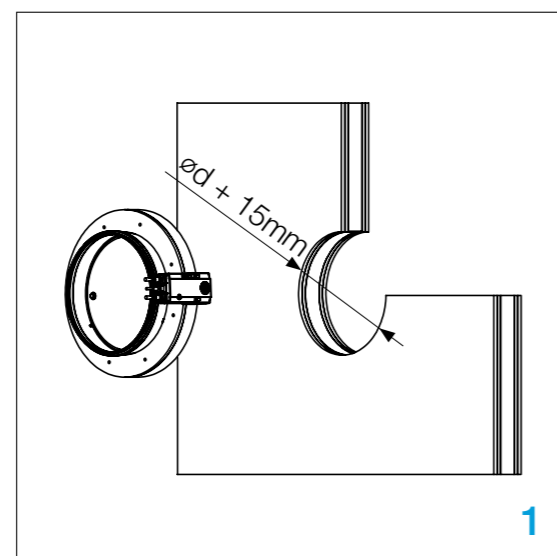

**Damper blade must be closed during installation!**

**Test the operation of the damper blade!**

## Subframe for installation in flexible wall

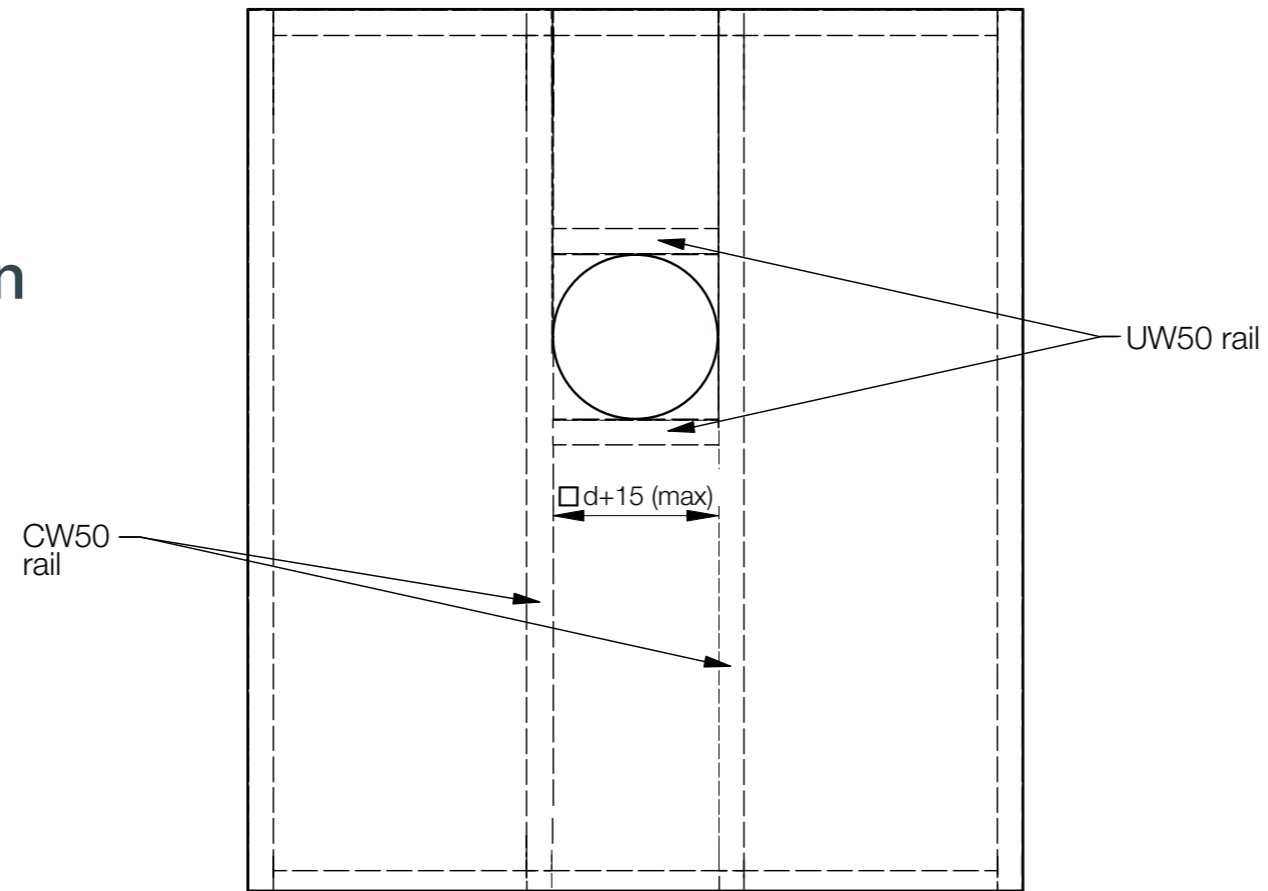

## Installation with profiles inserts

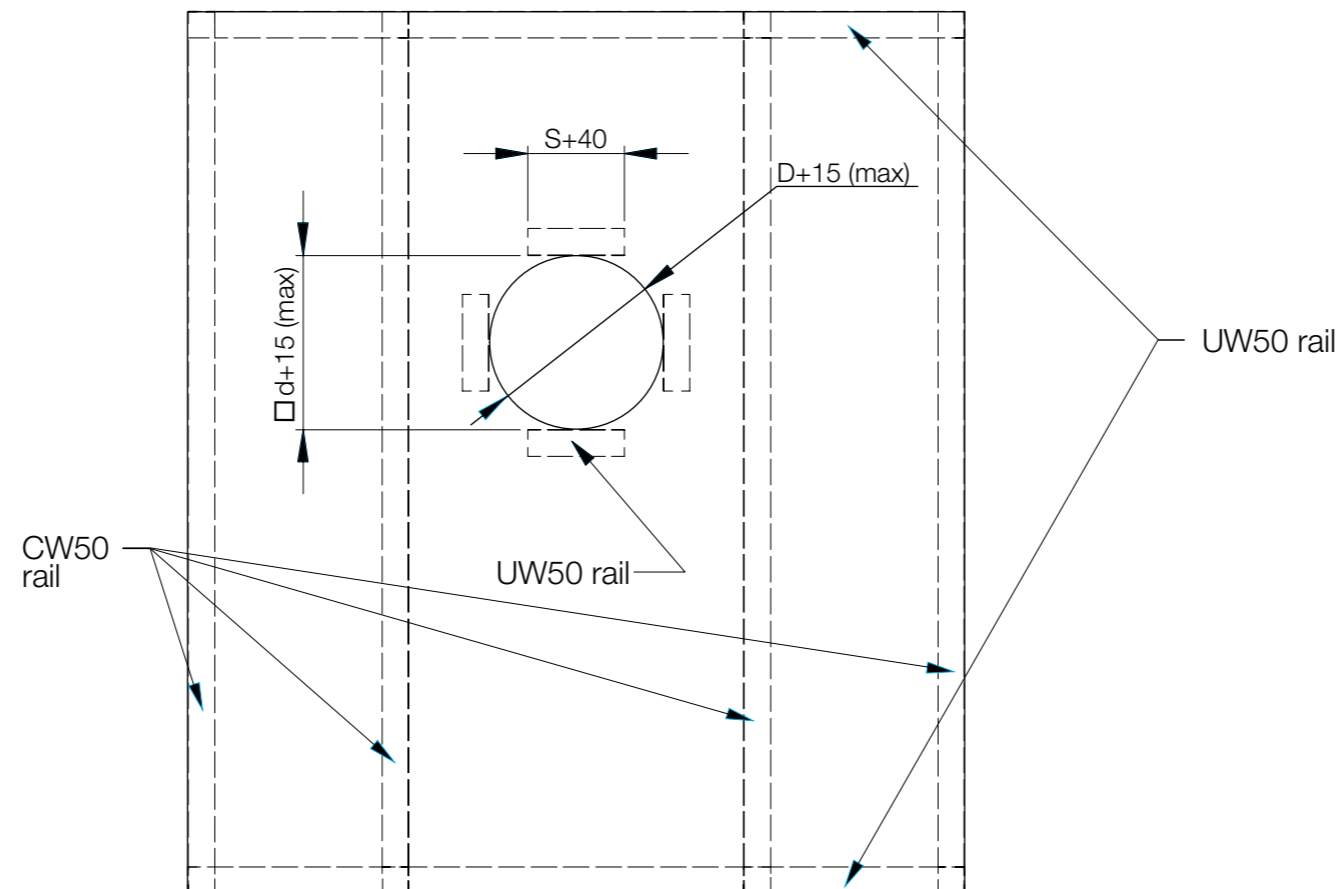

- ▼ [PRODUCT OVERVIEW](#)
- ▼ [DIMENSIONS](#)
- ▼ [INSTALLATIONS](#)
- ▼ [ACTUATORS](#)
- ▼ [ACCESSORIES](#)
- ▼ [MAINTENANCE AND OPERATION](#)



### FIRE DAMPER - FDC-DD

## Minimal installation distances

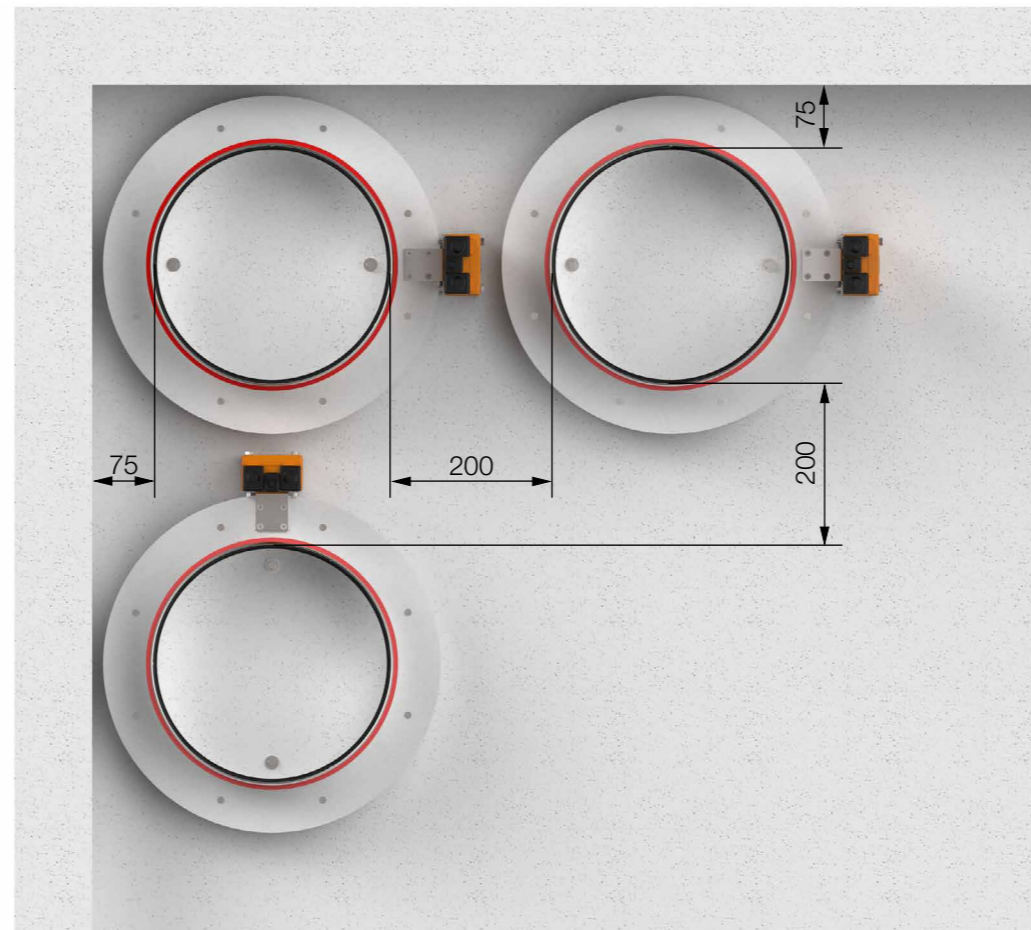

\*Minimum distance from the ceiling / wall or other fire dampers!

- ▼ [PRODUCT OVERVIEW](#)
- ▼ [DIMENSIONS](#)
- ▼ [INSTALLATIONS](#)
- ▼ [ACTUATORS](#)
- ▼ [ACCESSORIES](#)
- ▼ [MAINTENANCE AND OPERATION](#)

FIRE DAMPER - FDC-DD

# ELECTRIC ACTUATOR M24-S, M230-S

Damper is delivered in closed position. When electric actuator is connected to the power supply, damper blade will open. When the damper reaches the end position (damper open), the electro motor will stop. Closing fire damper takes place automatically when a power failure occurs. Thermal tripping device that comes with fire damper causes power circuit break at a temperature of 72 °C. If checking is needed for proper functioning of fire damper, pushing the switch on the thermal tripping device will close damper.



- ▼ [PRODUCT OVERVIEW](#)
- ▼ [DIMENSIONS](#)
- ▼ [INSTALLATIONS](#)
- ▼ [ACTUATORS](#)
- ▼ [ACCESSORIES](#)
- ▼ [MAINTENANCE AND OPERATION](#)

## ACTUATORS

## FIRE DAMPER - FDC-DD

When switch on tripping device is released, the damper will open. Damper can be opened without connecting to a voltage with enclosed handle by turning it in the direction of the arrow on electric actuator (clockwise). Damper can be locked in the desired position by pulling brake on Belimo BFL.

To unlock the electro motor, release brake for Belimo BFL. After release, damper will be closed by return spring. When damper is opened manually, electric actuator will not move the damper into closed position in case of power failure.

### Technical specifications

Type of Belimo actuator	BFL24-T	BFL230-T
Nominal voltage / power consumption	AC/DC 24 V, 50/60 Hz	AC 230 V, 50/60 Hz
opening	2,5 W	3,5 W
holding	0,8 W	1,1 W
for wire sizing	4 VA	6,5 VA
End switch	1 mA...3 A (0,5 A), DC 5 V...AC 250V	1 mA...3 A (0,5 A), DC 5 V...AC 250 V
Running time	motor < 60 s spring return ~20 s	motor < 60 s spring return ~20 s
Ambient temperature range	min. -30 °C, max. 50 °C	

### Wiring diagram

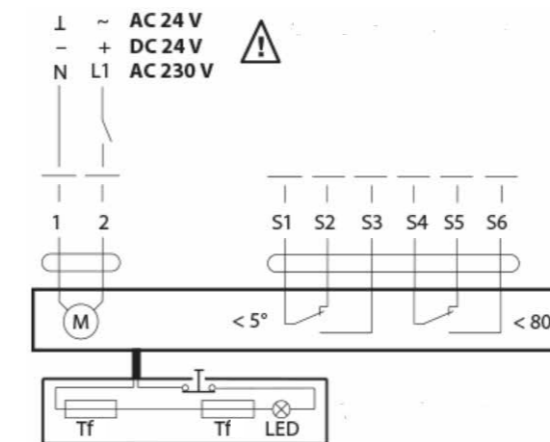

- 1 negative (direct-current) or neutral (alternating current)
- 2 positive (direct-current) or phase (alternating current)
- S1 common micro switch closed damper
- S2 normally closed micro switch closed damper
- S3 normally open micro switch closed damper
- S4 common micro switch open damper
- S5 normally closed micro switch open damper
- S6 normally open micro switch open damper
- Tf temperature sensor on the outer side of the duct (ambient temperature) max. 72 °C

## ACCESSORIES

C **Flexible duct connections** - Flexible duct connectors are used in HVAC systems for isolation from structure-borne noise, expansion compensation and fire damper connections (total length 150mm, flexible 60mm).

D/E **Safety grilles** - Fire damper, safety grille and, if applicable, extension piece are assembled at the factory to form a unit. The free cross sectional area of the cover grille is approx. 70%.

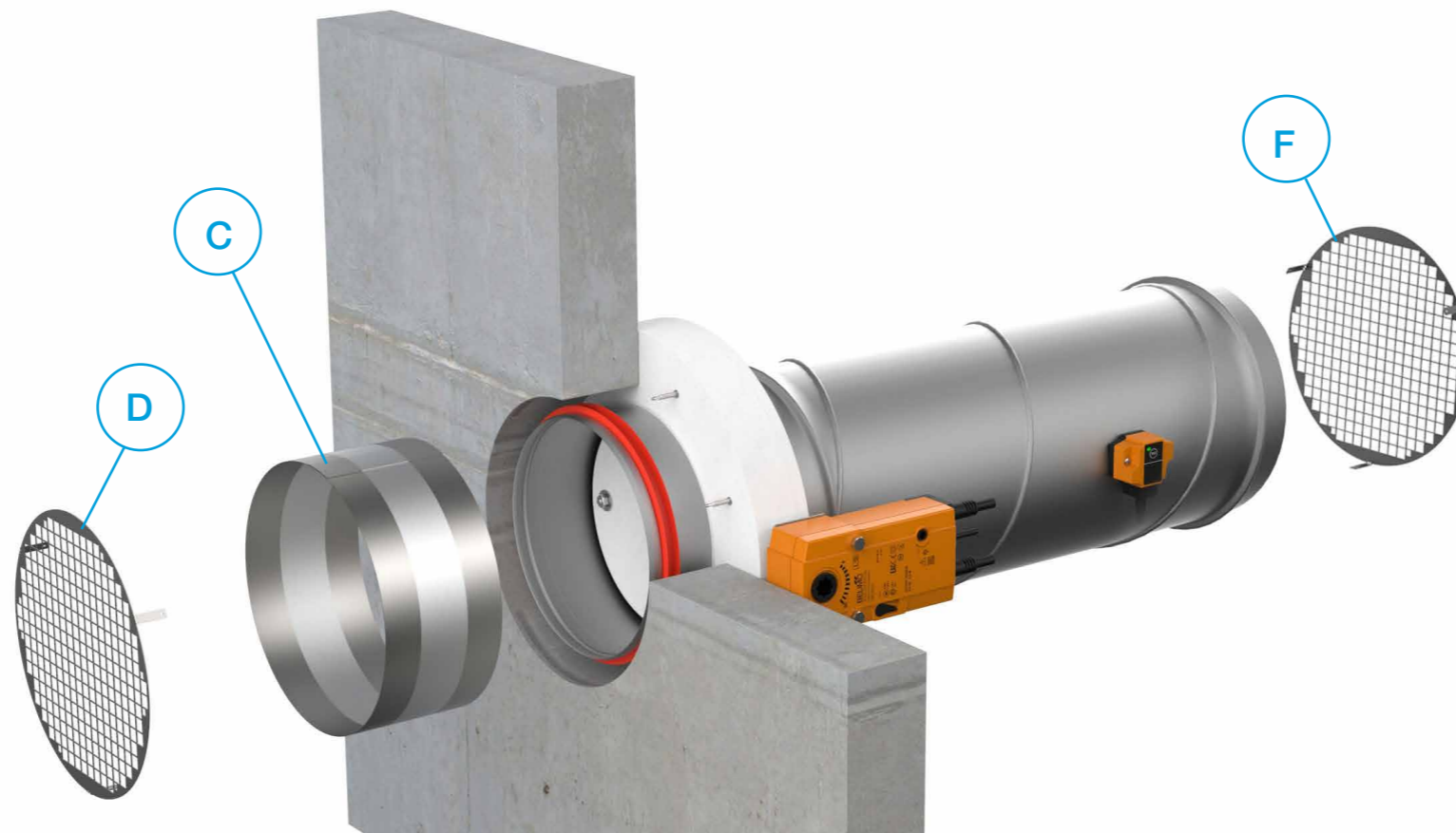

(1) Type (2) Accessories (3) Dimension

### FD-A - FLEX - d100

- (1) **FD-A** - Accessories for round fire damper (3) d100...d315 nominal diameter of the round fire damper
- (2) **FLEX** - Flexible duct connections (1pc) C  
**SG1** - Safety grill on operation side E  
**SG2** - Safety grill on installation side D

- ▼ [PRODUCT OVERVIEW](#)
- ▼ [DIMENSIONS](#)
- ▼ [INSTALLATIONS](#)
- ▼ [ACTUATORS](#)
- ▼ [ACCESSORIES](#)
- ▼ [MAINTENANCE AND OPERATION](#)

## + ACCESSORIES

## FIRE DAMPER - FDC-DD

- For safety reasons, parts need to be changed by a trained personnel or the manufacturer.
- **WARNING!** Install the original parts only!

A **Communication module bracket** FD-A-CMB

B **Belimo thermal fuse 72 °C** FD-A-BAT72

Drill hole (ø16 mm) for the fuse of Belimo mechanism and fix it with self-tapping screws.



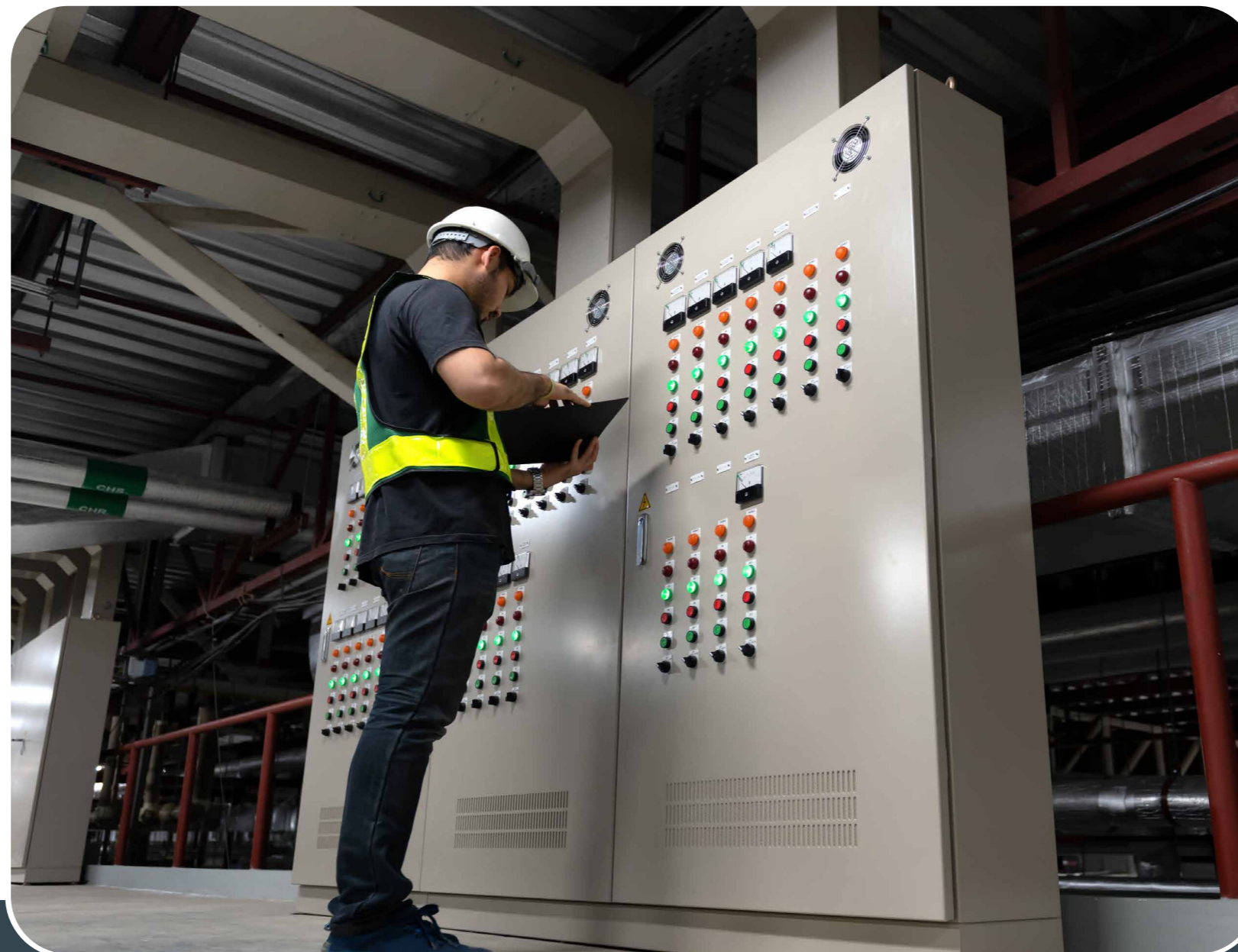

- ▼ [PRODUCT OVERVIEW](#)
- ▼ [DIMENSIONS](#)
- ▼ [INSTALLATIONS](#)
- ▼ [ACTUATORS](#)
- ▼ [ACCESSORIES](#)
- ▼ [MAINTENANCE AND OPERATION](#)



## MAINTENANCE

## FIRE DAMPER - FDC-DD

## TRANSPORT

After arrival, check the fire damper for transport damage and shortcomings. In case of any damage or shortcomings, immediately contact your supplier.

## STORAGE

If the damper is not installed immediately:

- Remove any wrapping.
- Protect fire damper from dust and contamination.
- Do not expose the fire damper to the effects of weather - store fire damper in dry place.
- Do not store the unit below -20 °C or above 50 °C.

Please properly dispose of packaging material.

## MAINTENANCE AND OPERATION

Fire dampers are designed with fully enclosed drive mechanism outside of the duct and as such do not require cleaning and regular maintenance.

However, activation mechanism should be inspected for proper operation on regular basis.

- Provide at least one annual check of the damper
- After each intervention, provide a systematic cleaning of dust
- Check if the electrical terminals are tightened
- Cleaning instruction: clean with a sponge, with water or a mild detergent
- Disinfection instruction: spray disinfectant (disinfectant may contain alcohol which is flammable, take precaution to avoid ignition)

It is not permitted to alter the dampers in any way nor perform any changes to their structure (except for the service procedures described in this manual) without the manufacturer's consent. Provide at least one annual check of the damper. The functional test must be carried out in compliance with the basic maintenance principles of the European norms EN 13306, EN 15423 and EN15650.

## COMMISSIONING

- Carefully unpack FDC-DD fire damper - be careful of sharp edges and do not use excessive force for unpacking
- Inspect the fire damper - check the fire damper for damage
- Installation of the fire damper - according to the installation instructions ([page 7.](#))
- Before commissioning: check the fire damper functions.





## FUNCTIONS

- Release mechanism:  
Damper blade can be closed and opened manually
- Electric actuator:  
Signal testing - the damper blade must close/open



## FIRE DAMPER - FDC-DD

---

 Systems House, Unit 33, Southern Cross, Business Park, Bray, Co. Wicklow, A98 HT99  
 +353 1 2761600  
 [info@safeguard.ie](mailto:info@safeguard.ie)  
 [www.safeguard.ie](http://www.safeguard.ie)

---